

# GD&T

QUALITY

## Tolerance Stack-up Analysis



**© 2018, Omnex, Inc.  
325 East Eisenhower Parkway, Suite 4  
Ann Arbor, MI 48108  
PH: (734) 761-4940  
FAX: (734) 761-4966**

**Second Edition  
May 2007**

**This publication is protected by Federal Copyright Law, with all rights reserved. No part of this publication may be reproduced, stored in a retrieval system, translated, transcribed, or transmitted, in any form, or by any means manual, electronic, electro-magnetic, mechanical, chemical, optical, or otherwise, without prior explicit written permission from Omnex, Inc.**



**Omnex provides training, consulting and software solutions to the international market with offices in the USA, Canada, Mexico, China (PRC), Germany, India, the Middle East, and SE Asia. Omnex offers over 400 standard and customized training courses in business, quality, environmental, food safety, laboratory and health & safety management systems worldwide.**

**Email: [info@omnex.com](mailto:info@omnex.com)**

**Web: [www.omnex.com](http://www.omnex.com)**



# A BRIEF INTRODUCTION TO OMNEX





## Omnex Introduction

- **International consulting, training and software development organization founded in 1985.**
- **Specialties:**
  - Integrated management system solutions.
  - Elevating the performance of client organizations.
  - Consulting and training services in:
    - Quality Management Systems, e.g. ISO 9001, IATF 16949, AS9100, QOS
    - Environmental Management Systems, e.g. ISO 14001
    - Health and Safety Management Systems, e.g. OHSAS 18001
- **Leader in Lean, Six Sigma and other breakthrough systems and performance enhancement.**
  - Provider of Lean Six Sigma services to Automotive Industry via AIAG alliance.



## About Omnex

- **Headquartered in Ann Arbor, Michigan with offices in major global markets.**
- **In 1995-97 provided global roll out supplier training and development for Ford Motor Company.**
- **Trained more than 100,000 individuals in over 30 countries.**
- **Workforce of over 400 professionals, speaking over a dozen languages.**
- **Former Delegation Leader of the International Automotive Task Force (IATF) responsible for ISO/TS 16949.**
- **Served on committees that wrote QOS, ISO 9001:2000, QS-9000, ISO/TS 16949 and its Semiconductor Supplement, and ISO IWA 1 (ISO 9000 for healthcare).**
- **Member of AIAG manual writing committees for FMEA, SPC, MSA, Sub-tier Supplier Development, Error Proofing, and Effective Problem Solving (EPS).**



# Omnex Worldwide Offices



Omnex is headquartered and operates from the United States through offices in Michigan.

The company maintains international operations in many countries to provide comprehensive services to clients throughout Western Europe, Latin America and the Pacific Rim.

[www.omnex.com](http://www.omnex.com)  
[info@omnex.com](mailto:info@omnex.com)

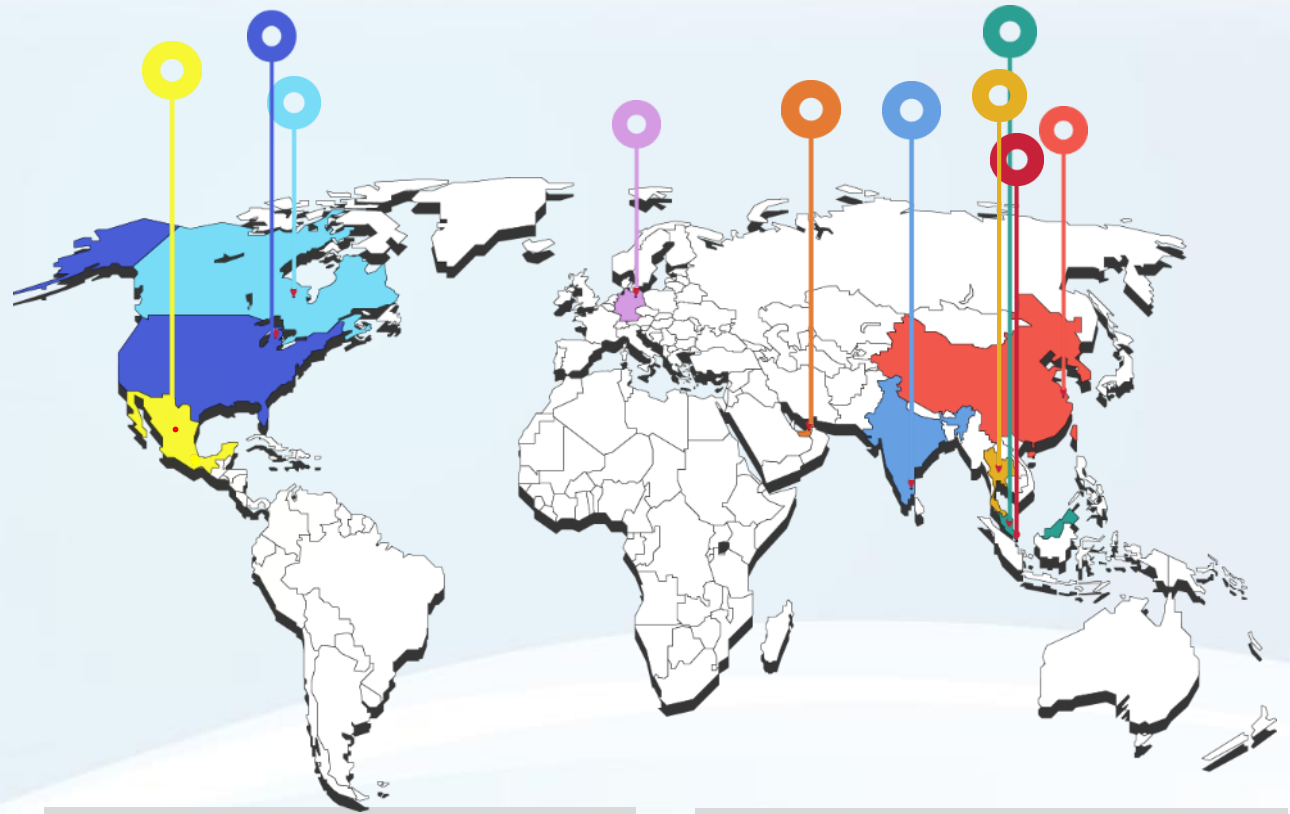

- Omnex Global Head Quarters (Michigan, USA)  
West Coast Operations (San Jose, CA)
- Middle East (Dubai, Saudi Arabia, Bahrain)
- Asia Pacific HQ (Chennai, Pune, Delhi, Bangalore)
- Thailand (Bangkok)
- China (Shanghai, Guangzhou, Wuhan, Chengdu)
- Mexico (Monterrey)
- Canada (Mississauga)
- Singapore
- Europe (Berlin, Germany)
- Malaysia (Kuala Lumpur)



## Rules of the Classroom

- ✓ **Start and end on time**
- ✓ **Return from breaks and lunch on time**
- ✓ **All questions welcome**
- ✓ **Your input is valuable and is encouraged**
- ✓ **Don't interrupt others**
- ✓ **One meeting at a time**
- ✓ **Listen – and respect others' ideas**
- ✓ **No “buts” – keep an open mind**
- ✓ **Cell phones & pagers off or silent mode**
- ✓ **No e-mails, texting or tweeting during class**
- ✓ **If you must take a phone call or answer a text please leave the room for as short a period as possible**

## Icebreaker

- **Instructor Information:**
  - Name
  - Background
- **Student Introductions:**
  - Name
  - Position / Responsibilities
  - What is your involvement in the new product development process?
  - What are your experiences with APQP?
  - Please share something unique and/or interesting about yourself.





# Chapter #1

QUALITY

## Tolerance Stack-up Introduction



# What is Dimension and Tolerance

There are two components to the definition of part geometry:

1. nominal state: Nominal Dimension:
2. allowable variation: Tolerance :

Two dimensioning system: OMNEX

1. plus/minus dimensions and tolerances
2. GD&T Geometric Dimensioning and Tolerancing GD&T

Or combination of both systems.

**the best way to tolerance features is by using GD&T. GD&T is the only way to ensure that everyone interprets the dimensioning and tolerancing specifications the same way.**



# Tolerance Stack up Questions

Tolerance Stack ups provide a numerical answer to a question. Typical questions include:

- Will these two surfaces interfere?
- What is the minimum distance between the bolt head and the flange at  $90^\circ$  ?
- What is the maximum thickness of the two parts that must fit within this groove?
- Will the pin fit within the hole?
- How large can the body of the switch be and still assemble?
- What is the worst-case largest angle possible between these surfaces?
- How do I know if the worst-case assembly will satisfy its dimensional objectives?
- If we reduce the size of the clearance holes, will the parts still assemble?
- Will the dimensioning and tolerancing scheme used on the parts allow too much variation at assembly? Should the drawings be redimensioned and retoleranced to reduce the accumulation of tolerances?
- If we chuck the part using this diameter, how much tolerance is allowed for the smaller coaxial diameter?

### Tolerance Stack up Target

1. Optimize the tolerances of parts and assemblies in a new design.
2. Balance accuracy, precision, and cost with manufacturing process capability.
3. Determine the part tolerances required to satisfy a final assembly condition.
4. Determine the allowable part tolerances if the assembly tolerance is known.
5. Determine if the parts will work at their worst-case condition or with the maximum statistical variation.
6. Determine if the specified part tolerances yield an acceptable amount of variation between assembled components.
7. Troubleshoot malfunctioning existing parts or assemblies.
8. Determine the effect changing a tolerance value will have on assembly function.
9. Explore design alternatives using different or modified parts.

# Accuracy vs Precision

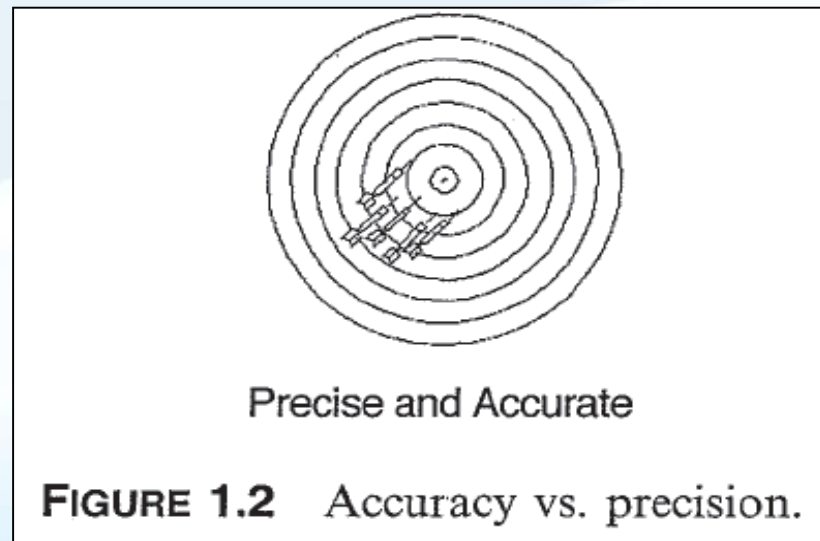
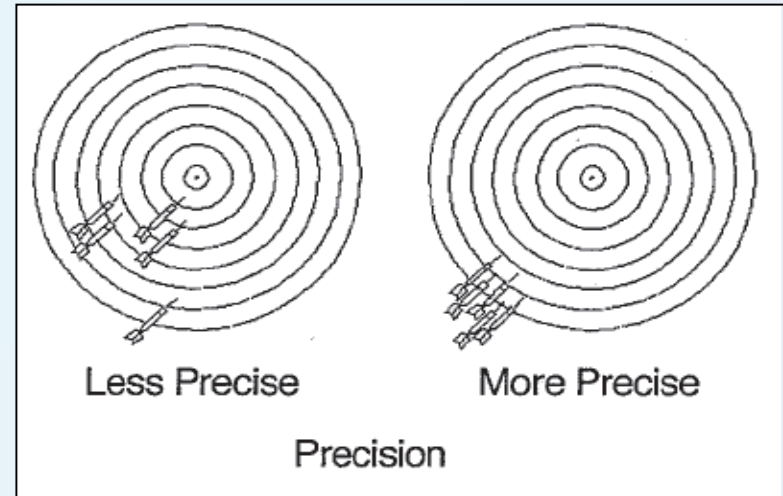
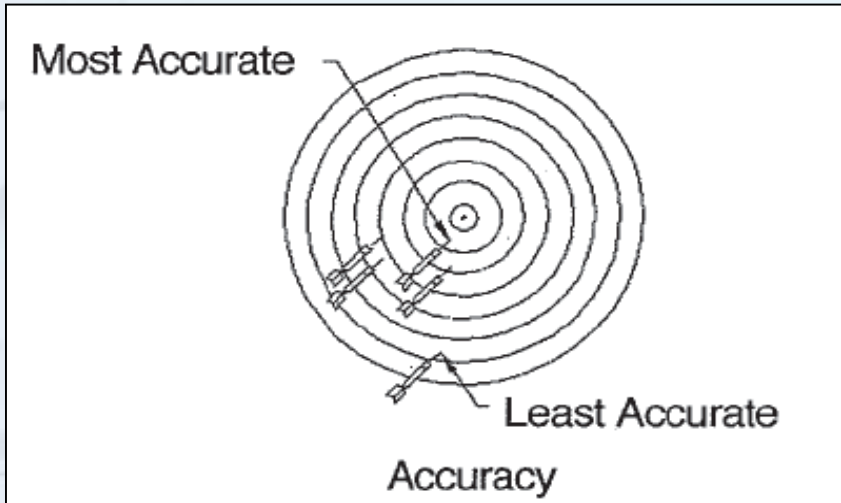

**FIGURE 1.2** Accuracy vs. precision.

# Chapter #2

QUALITY

## Dimensioning and Tolerancing



### Types Of Dimensions - Linear and angular dimensions

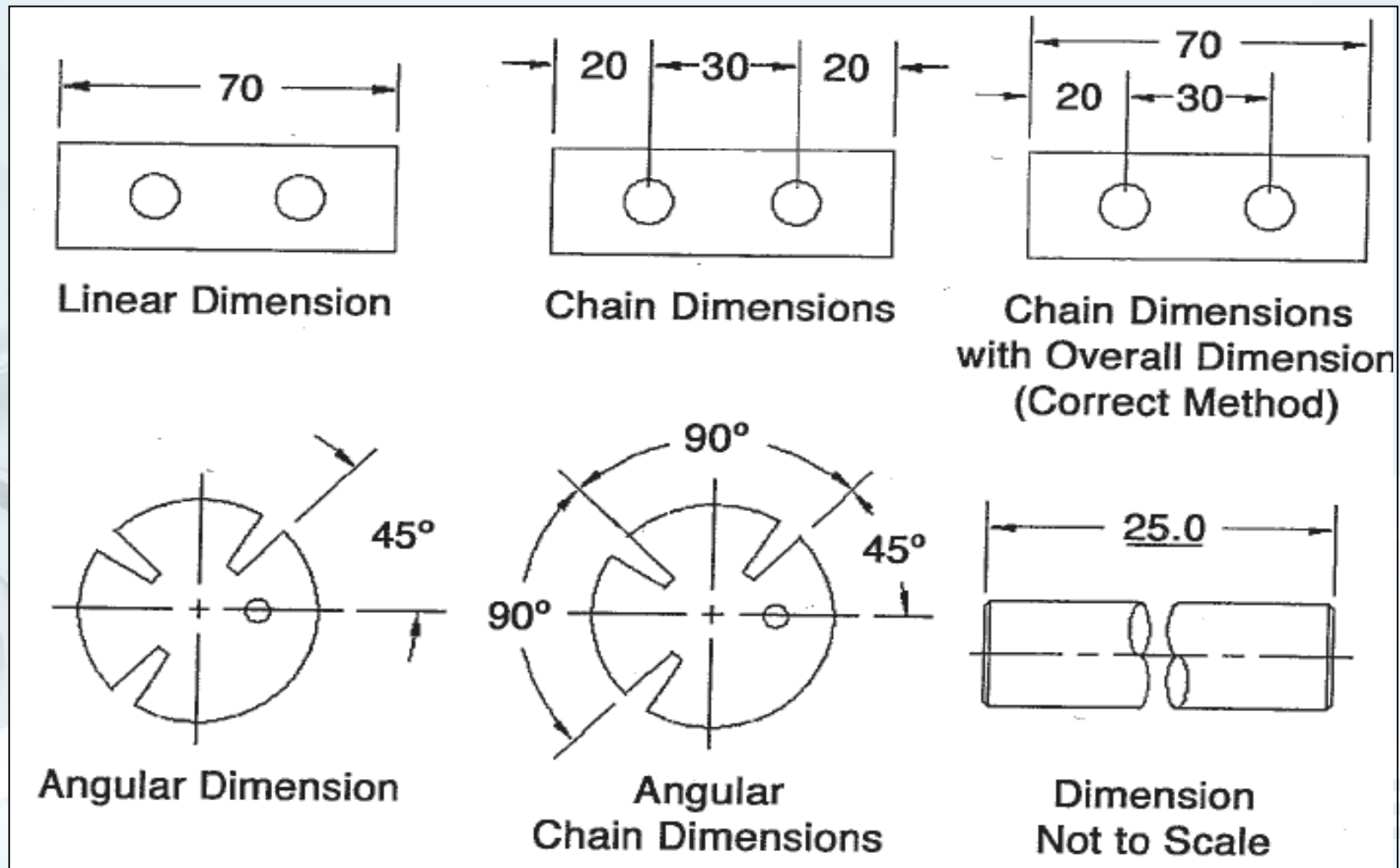

Types Of Dimensions - Linear and angular dimensions

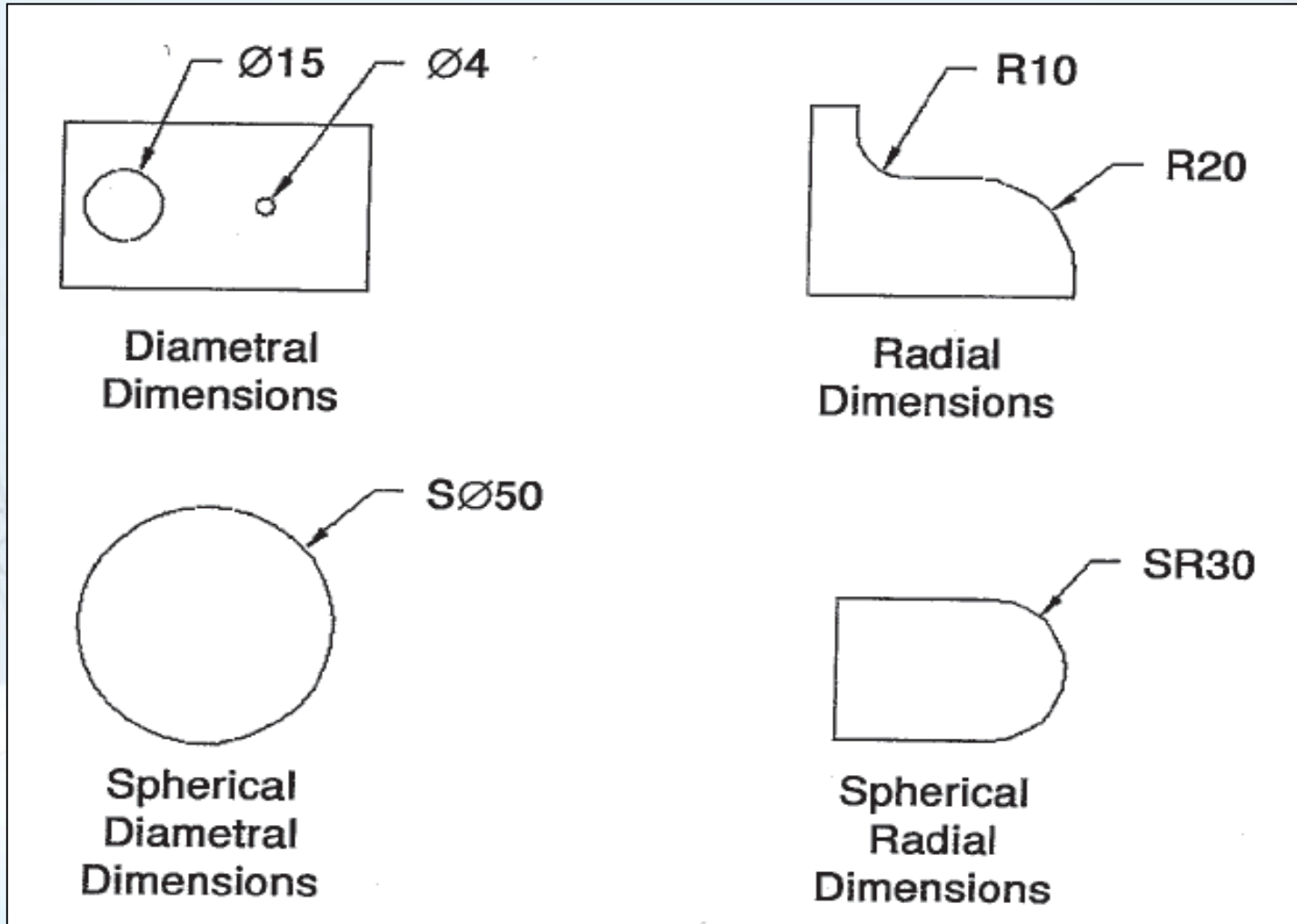



### Types Of Dimensions - Rectangular' coordinate dimensioning

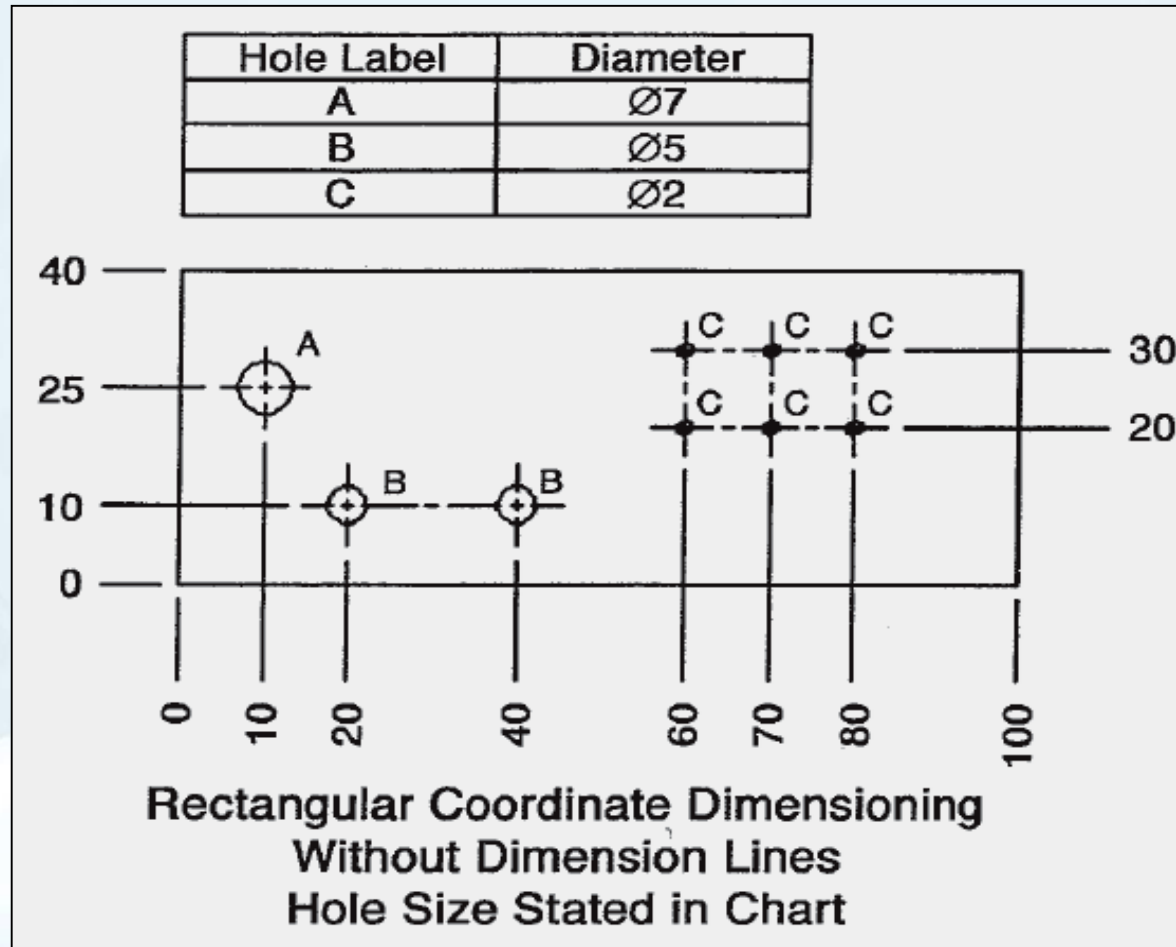



Types Of Dimensions - Rectangular' coordinate dimensioning

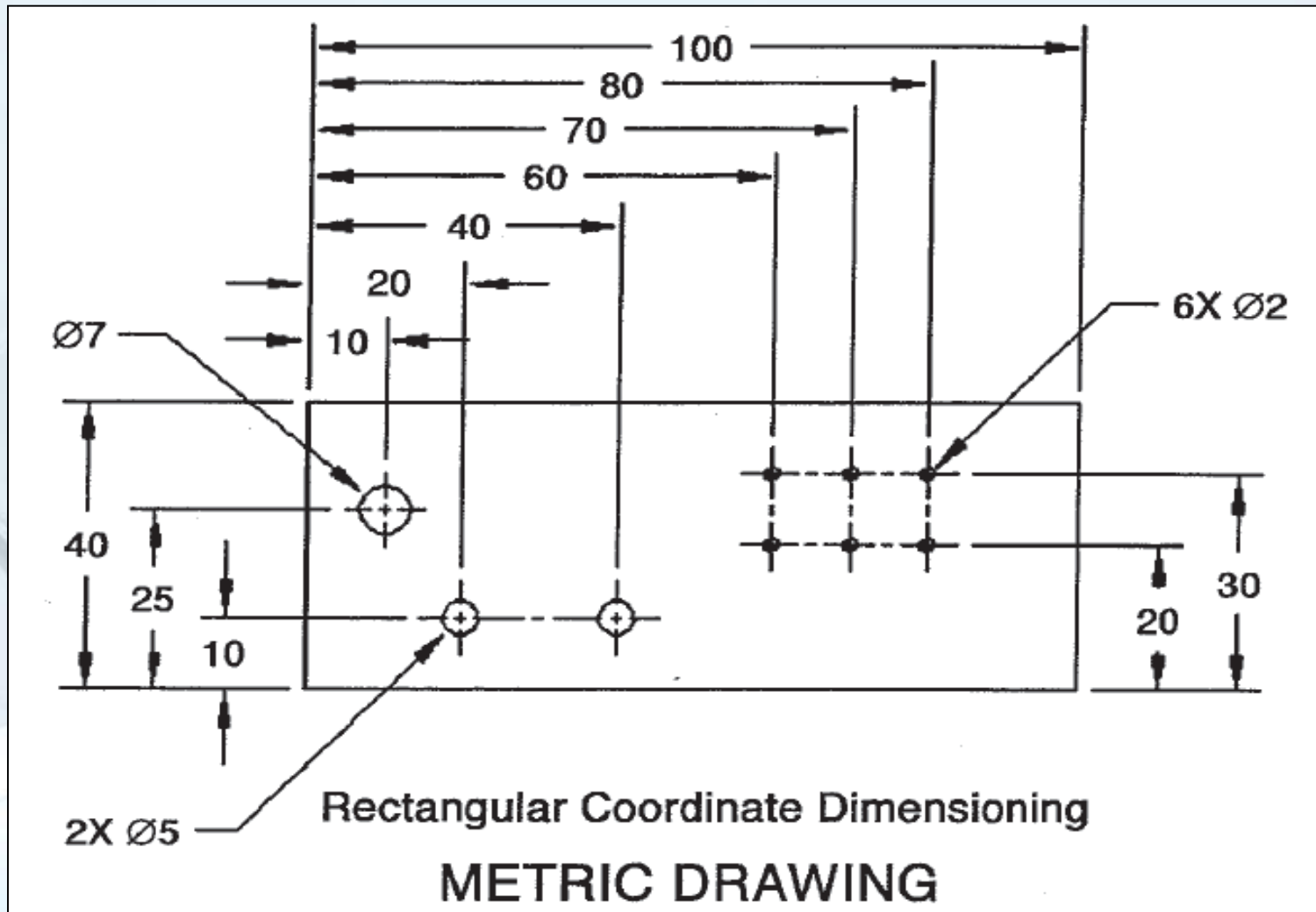

### How to Specify Tolerance

- Tolerances may be stated specifically or generically as described below:
  1. Title Block or General Note Tolerances
  2. Local Plus/Minus Tolerances
  3. GD&T

**Note: only linear units may be specified in a feature control frame.** o.m.n.ex

**Dimensions must be arranged and related in such a way to minimize tolerance accumulation between related features.**

# GD&T Drawing

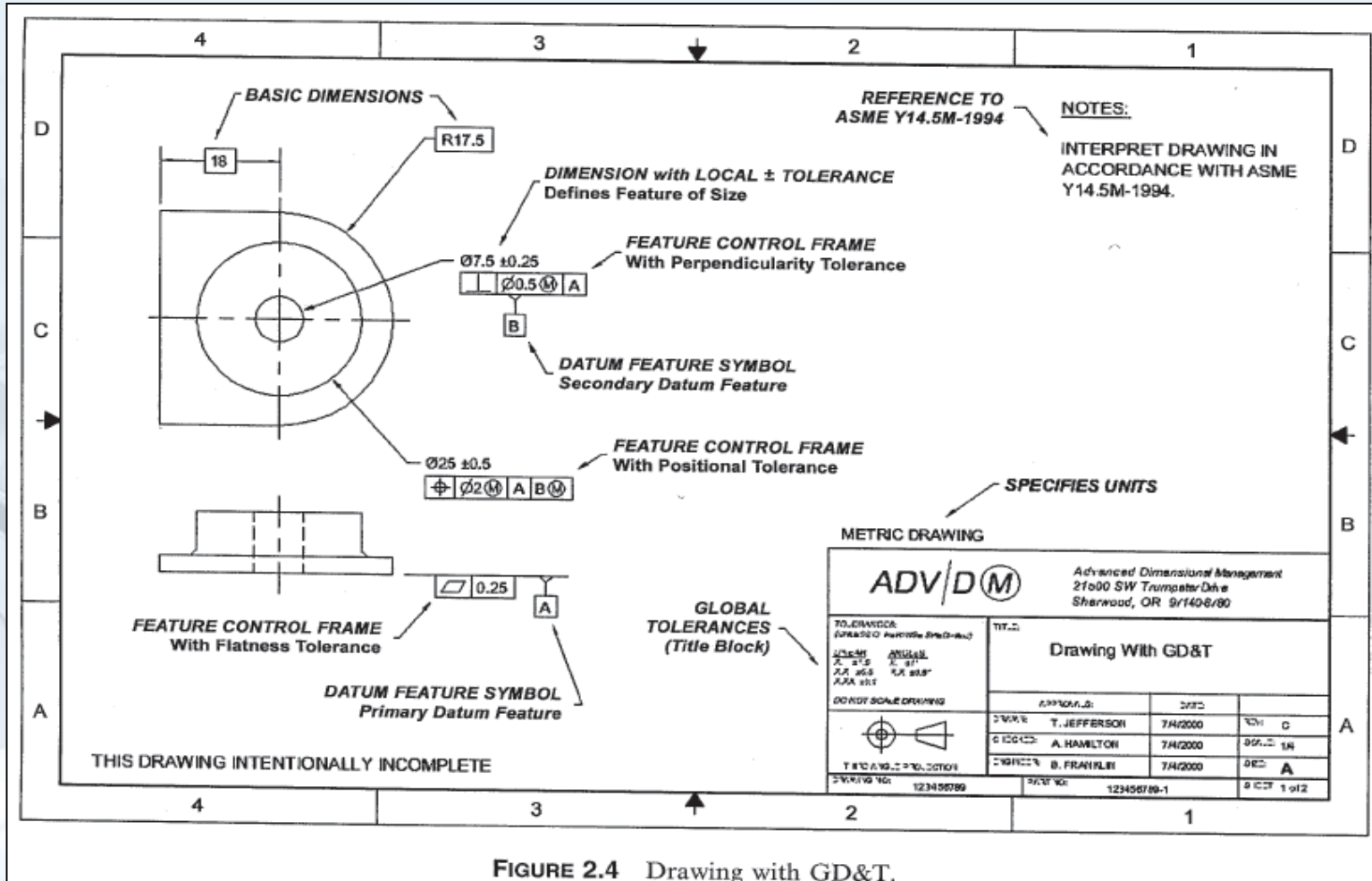

### Geometric Tolerance Symbol













Geometric Tolerances	
	GEOMETRIC TOLERANCE AND SYMBOL
FORM TOLERANCES	— STRAIGHTNESS
	 FLATNESS
	 CIRCULARITY (ROUNDNESS)
	 CYLINDRICITY
ORIENTATION TOLERANCES	 ANGULARITY
	 PERPENDICULARITY
	 PARALLELISM
LOCATION TOLERANCES	 POSITION
	 CONCENTRICITY
	 SYMMETRY
PROFILE TOLERANCES	 PROFILE OF A LINE
	 PROFILE OF A SURFACE
RUNOUT TOLERANCES	 CIRCULAR RUNOUT
	 TOTAL RUNOUT

FIGURE 2.5 GD&T symbology.

### Feature Characteristics And Associated Tolerance Types

#### four types of tolerances:

- Size tolerances
- Form tolerances
- Orientation tolerances
- Location tolerances

### Feature Characteristics And Associated Tolerance Types

- **Size:**

Only features of size have size as defined in the ASME Y14.5M-1994 standard. Therefore, only those features that are features of size require a size tolerance.

Some features, such as a single planar feature, do not have size characteristics and therefore do not require a size tolerance to be completely defined.

### Feature Characteristics And Associated Tolerance Types

- **Form**

every feature must have a form tolerance, either directly or indirectly specified.

directly specified form tolerances include flatness, circularity, cylindricity, and straightness.

indirectly specified form tolerance comes with rule #1, a profile of a surface tolerance to a basically defined surface. profile of a surface may control form, orientation, location, and possibly even size

indirect methods of controlling form can be overridden by specifying a form tolerance with a smaller value.



### Feature Characteristics And Associated Tolerance Types

- **Orientation**

can be considered as the angle between features, or more precisely, orientation is the amount a feature may tilt relative to a datum reference frame.

Aside from the primary datum feature, every feature on a part is oriented to other features. A primary datum feature is exempt because all other features are directly or indirectly oriented to it.

### Feature Characteristics And Associated Tolerance Types

- Orientation may also be controlled directly or indirectly.
- Dimensions with  $\pm$  tolerances for all features rely on the default angular  $\pm$  tolerance in the title block to control the orientation of all features.
- Other methods of indirectly specifying an orientation tolerance occur where a profile of a surface tolerance is related to a datum reference frame and where a positional tolerance is related to a datum reference frame—both of these cases control orientation and may also control size, form, and location.

### Feature Characteristics And Associated Tolerance Types

- Location tolerances must be directly specified, as they are not subsets of other tolerance types.

For example, a positional tolerance related to a datum reference frame controls orientation as a subset of position, but only positional, run out, concentricity, symmetry and profile tolerances control location.

# Chapter #3

QUALITY

## Tolerancing Format and Decimal Places



## Chapter #3 Tolerancing Format and Decimal Places

### Types of Tolerancing

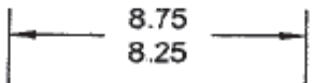
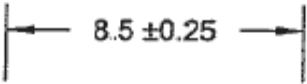
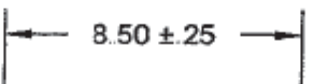
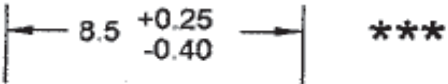
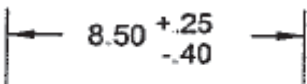
<u>Tolerancing with SI Units:</u> <u>(millimeters)</u>	<u>Tolerancing with U.S. Customary Units:</u> <u>(inches)</u>
<p style="text-align: center;">Limit Dimension</p>  <p style="text-align: center;">Same number of decimal places in both limits.</p>	<p style="text-align: center;">Limit Dimension</p>  <p style="text-align: center;">Same number of decimal places in both limits.</p>
<p style="text-align: center;">Equal Bilateral Tolerancing</p>  <p style="text-align: center;">Number of decimal places may be different for dimension and tolerance.</p>	<p style="text-align: center;">Equal Bilateral Tolerancing</p>  <p style="text-align: center;">Number of decimal places must be the same for dimension and tolerance.</p>
<p style="text-align: center;">Unequal Bilateral Tolerancing</p>  <p style="text-align: center;">Number of decimal places may be different for dimension and tolerances. Both tolerances must have the same number of decimal places.</p>	<p style="text-align: center;">Unequal Bilateral Tolerancing</p>  <p style="text-align: center;">Number of decimal places must be the same for dimension and both tolerances.</p>

## Chapter #3 Tolerancing Format and Decimal Places

### Types of Tolerancing

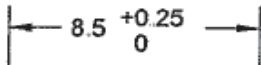
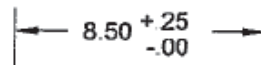
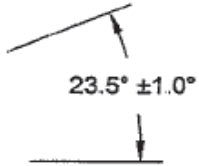
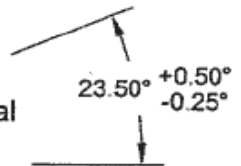
<u>Tolerancing with SI Units:</u> <u>(millimeters)</u>	<u>Tolerancing with U.S. Customary Units:</u> <u>(inches)</u>
<p style="text-align: center;">Unilateral Tolerancing</p>  <p>Number of decimal places may be different for dimension and tolerances. The zero tolerance has no decimal places and is not preceded by a + or - sign.</p>	<p style="text-align: center;">Unilateral Tolerancing</p>  <p>Number of decimal places must be the same for dimensions and both tolerances.</p>
<p>Leading zeroes for dimensions and tolerances. Trailing zeroes only used in certain applications, (marked ***).</p>	<p>No leading zeroes for dimension values. Trailing zeroes used where needed.</p>
<p>Angular Dimensions and Tolerances</p> <div style="display: flex; justify-content: space-around; align-items: center;"> <div style="text-align: center;"> <p>Equal Bilateral</p>  </div> <div style="text-align: center;"> <p>Unequal Bilateral</p>  </div> </div> <p>Angles may be specified using decimal degrees or degrees, minutes and seconds. If decimal degrees are used, the number of decimal places must be the same for the dimension and both tolerances. Angular dimensions and tolerances follow the same rules on drawings prepared using either type of units.</p>	

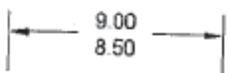
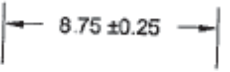
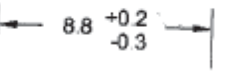
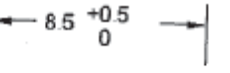
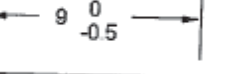

## Tolerance Limit and Statistic Tolerancing

<p><b>Limit Dimension</b></p> 	<p><b>Dimensional Limits:</b> 9.00 8.50</p>
<p><b>Equal Bilateral Tolerancing</b></p> 	<p><b>Dimensional Limits:</b> 9.00 8.50</p>
<p><b>Unequal Bilateral Tolerancing</b></p> 	<p><b>Dimensional Limits:</b> 9.00 8.50</p>
<p><b>Unilateral Tolerancing - Positive</b></p> 	<p><b>Dimensional Limits:</b> 9.00 8.50</p>
<p><b>Unilateral Tolerancing - Negative</b></p> 	<p><b>Dimensional Limits:</b> 9.00 8.50</p>

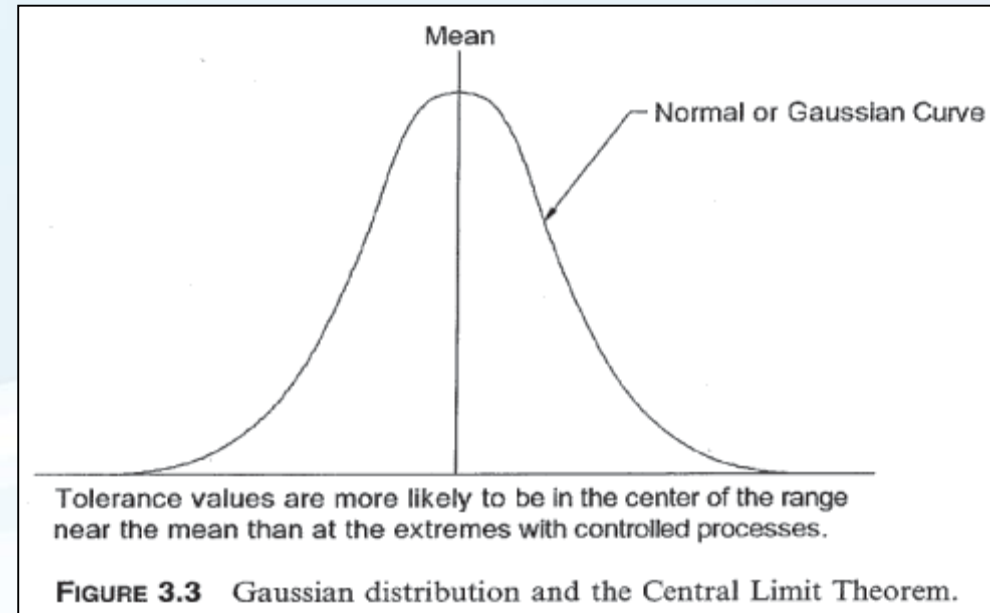



# Chapter #4

QUALITY

## Tolerancing Converting



### Converting Limit Dimensions to Equal Bilateral Format

#### Example #4.1

- Given a limit dimension,  
10.00 Upper limit (metric format)  
9.55 Lower limit (metric format)

$$\text{Total tolerance} = 10 - 9.55 = 0.45$$

$$\text{Equal bilateral tolerance value} = \frac{0.45}{2} = 0.225$$

$$\text{Adjusted nominal value} = 9.55 + 0.225 = 9.775$$

Conversion complete:

$$\text{Equal bilateral equivalent} = 9.775 \pm 0.225$$

## Chapter #4 Tolerancing Converting

### Converting Limit Dimensions to Equal Bilateral Format

#### Example #4.2

$$8.50 \begin{matrix} + .25 \\ - .10 \end{matrix}$$

$$\text{Upper limit} = 8.50 + .25 = 8.75$$

$$\text{Lower limit} = 8.50 - .10 = 8.40$$

$$\begin{aligned} \text{Total tolerance derived from given tolerances} \\ = .25 + .10 = .35 \end{aligned}$$

$$\text{Equal bilateral tolerance value} = \frac{.35}{2} = .175$$

$$8.40 + .175 = 8.575$$

Conversion complete :

$$\text{Equal bilateral equivalent} = 8.575 \pm .175$$

### Converting Limit Dimensions to Equal Bilateral Format

#### Example #4.3

$$8.50 \begin{matrix} + .25 \\ - .00 \end{matrix}$$

Conversion complete :

$$\text{Equal bilateral equivalent} = 8.625 \pm .125$$

#### Example #4.4

$$8.5 \begin{matrix} 0 \\ -0.25 \end{matrix}$$

Conversion complete:

$$\text{Equal bilateral equivalent} = 8.375 \pm 0.125$$

### Mean Shift

- In converting unequal bilaterally and unilaterally toleranced dimensions to equal bilateral format, the dimension value changed to the midpoint or mean of the tolerance range.
- Where dimensions are included in the Tolerance Stack up, the mean shift is little more than a curiosity, as it has no effect on the outcome of the Tolerance Stack up.
- The mean shifts are accounted for in the Tolerance Stack up method. Using more advanced and streamlined methods where the dimensions are not included and only the tolerances are manipulated, the mean shift must be accounted for.

### Mean Shift

#### Example #4.1a

### No Mean Shift

*Example 4.1a. Mean Shift Calculation for Limit Dimensions Converted into Equal Bilateral Format*

- Given a limit dimension,  
10.00 Upper limit (metric format)  
9.55 Lower limit (metric format)

#### Example #4.2a

$$8.50 \begin{matrix} + .25 \\ - .10 \end{matrix}$$

$$8.575 \pm .175$$

Converted dimension value (mean) – original dimension value (nominal) = mean shift

$$\text{Mean shift} = 8.575 - 8.50 = .075$$

### With Mean Shift

### Mean Shift

#### Example #4.3a

$$8.50 \begin{array}{l} + .25 \\ - .00 \end{array}$$

$$8.625 \pm .125$$

$$\text{Mean shift} = 8.625 - 8.50 = .125$$

#### Example #4.4a

$$8.5 \begin{array}{l} 0 \\ -0.25 \end{array}$$

$$8.375 \pm 0.125$$

$$\text{Mean shift} = 8.375 - 8.50 = -0.125$$



# Chapter #5

QUALITY

## Source of Variation



### Sources of Variation

1. Tolerances specified on the drawing
2. Variation encountered in the inspection process
3. Variation encountered in the assembly process . O-M-N-E-X

only specified tolerances, datum feature shift and assembly shift should be included in a Tolerance Stack up, the other sources of variation are merely included here for descriptive purposes.

### Sources of Variation

- Manufacturing Process Limitations (Process Capability)
- Tool Wear
- Operator Error and Operator Bias
- Variations in the material from the foundry, or material formed or cut by a 5. previous process contribute to possible variation.
- Ambient Conditions
- Difference in Processing Equipment
- Difference in Process
- Poor Maintenance
- Inspection Process Variation and Shortcuts
- Assembly Process Variation

# Chapter #6

QUALITY

## Tolerance Analysis



### What Is Tolerance Analysis?

Tolerance Analysis is a global term that includes two subcategories:

1. To determine the meaning of individual tolerancing specifications;
2. To determine the cumulative variation possible between two or more features.

The second part of the definition is commonly called a Tolerance Stack up.

### Typical questions of Tolerance Stack up

- Will these two surfaces touch in their worst case? If so, how much will they interfere?
- What is the minimum distance between the bolt head and the flange at  $90^\circ$  ?
- What is the maximum thickness of the two parts that must fit within this groove?
- Will the pin fit within the hole?
- How large can the body of the switch be and still assemble?
- What is the worst-case largest angle possible between these surfaces?
- How do I know if the worst-case assembly will satisfy its dimensional objectives?
- Why is there interference between these existing parts?  
is the interference allowed by the part tolerances and the assembly process?
- If we reduce the size of the clearance holes, will the parts still assemble?
- Will the dimensioning and tolerancing scheme used on the parts allow too much variation at assembly? Should the drawings be redimensioned and retoleranced to reduce the accumulation of tolerances?
- If we chuck the part using this diameter, how much tolerance is allowed for the smaller coaxial diameter?



## Chapter #6 Tolerance Analysis

### Steps of Tolerance Stack up

1. The distance to be studied is identified and labeled.
2. The positive and negative directions of the Tolerance Stack up are identified.
3. A Tolerance Stack up sketch is created.
4. The dimensions in the positive direction are added together.
5. The dimensions in the negative direction are added together.
6. The negative direction total is subtracted from the positive direction total to find the “nominal” distance.
7. All applicable tolerances are added together. This is the total possible variation.
8. Half of the total possible variation is added to the nominal distance to find the Upper Limit for the distance.
9. Half of the total possible variation is subtracted from the nominal distance to find the lower limit for the distance.

### **A Tolerance Stack up allows the designer to**

- 1. To Optimize the tolerances of parts and assemblies in a new design.**
- 2. Balance accuracy, precision, and cost with manufacturing process capability.**
- 3. Determine the part tolerances required to satisfy a final assembly condition.**
- 4. Determine the allowable part tolerances if the assembly tolerance is known.**
- 5. Determine if the parts will work at their worst-case condition or with the maximum statistical variation.**
- 6. Determine if the specified part tolerances yield an acceptable amount of variation between assembled components.**
- 7. Troubleshoot malfunctioning existing parts or assemblies.**
- 8. Determine the effect changing a tolerance value will have on assembly function.**
- 9. Explore design alternatives using different or modified parts.**

### Four Main Factors That Determine Which Dimensions And Tolerances Are Included In A Tolerance Stack Up

- The geometry of parts and assemblies that contribute to the distance being studied in the Tolerance Stack up
- The dimensioning and tolerancing schemes on the drawings of the parts and assemblies in the Tolerance Stack up
- The assembly process, how the parts are assembled
- The direction of the Tolerance Stack up and the direction of the dimensions and tolerances

### Methods And Types Of Tolerance Analysis

#### 1. Manually modeled:

Manually modeled analyses are done by hand, using pen and paper, or spreadsheet programs. Manual analyses are limited to linear (one-dimensional) variation.

#### 2. Computer modeled.

Three-dimensional analyses are best suited to computer-modeling tools. Computer modeled analyses are performed by computer statistical simulation programs. Programs are available for one-, two-, and three- dimensional analyses.

Tolerance Stack ups are performed to determine the variation of a single untoleranced dimension or distance.

### The direction of a linear Tolerance Stackup

- The direction of a linear Tolerance Stack up is always along a straight line.
- Dimensions and tolerances on surfaces at an angle to the Tolerance Stack up direction may need to be projected into the direction of the Tolerance Stack up using trigonometry.
- Dimensions and tolerances that are perpendicular to the Tolerance Stack up direction typically have no effect on the Tolerance Stack up and are usually not included in the chain of Dimensions and Tolerances.

### There are two major types of Tolerance Analysis

#### 1. worst-case (arithmetic):

Worst-case tolerance analyses represent the largest (worst-case) possible variation.

#### 2. statistical Tolerance Analysis:

For a Tolerance Stack up with many dimensions and tolerances, statistical tolerance analyses may be more appropriate.



## Chapter #6 Tolerance Analysis

### Examples of Tolerance Stackup

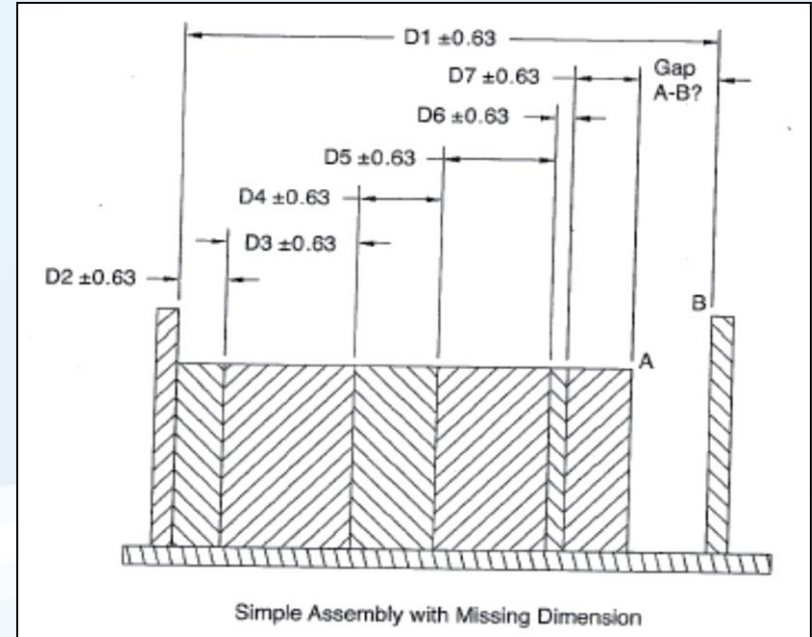
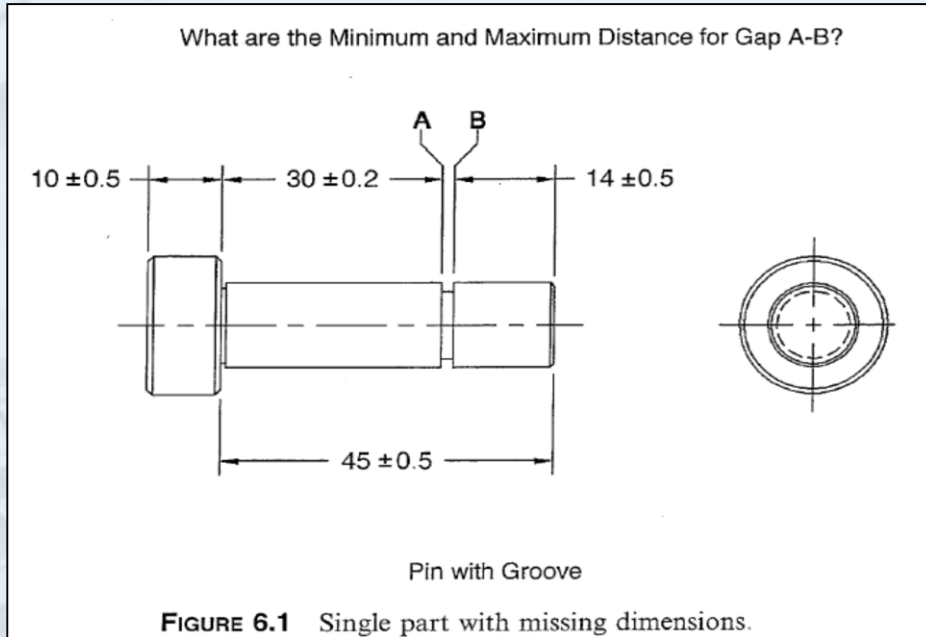

## Examples of Tolerance Stack up

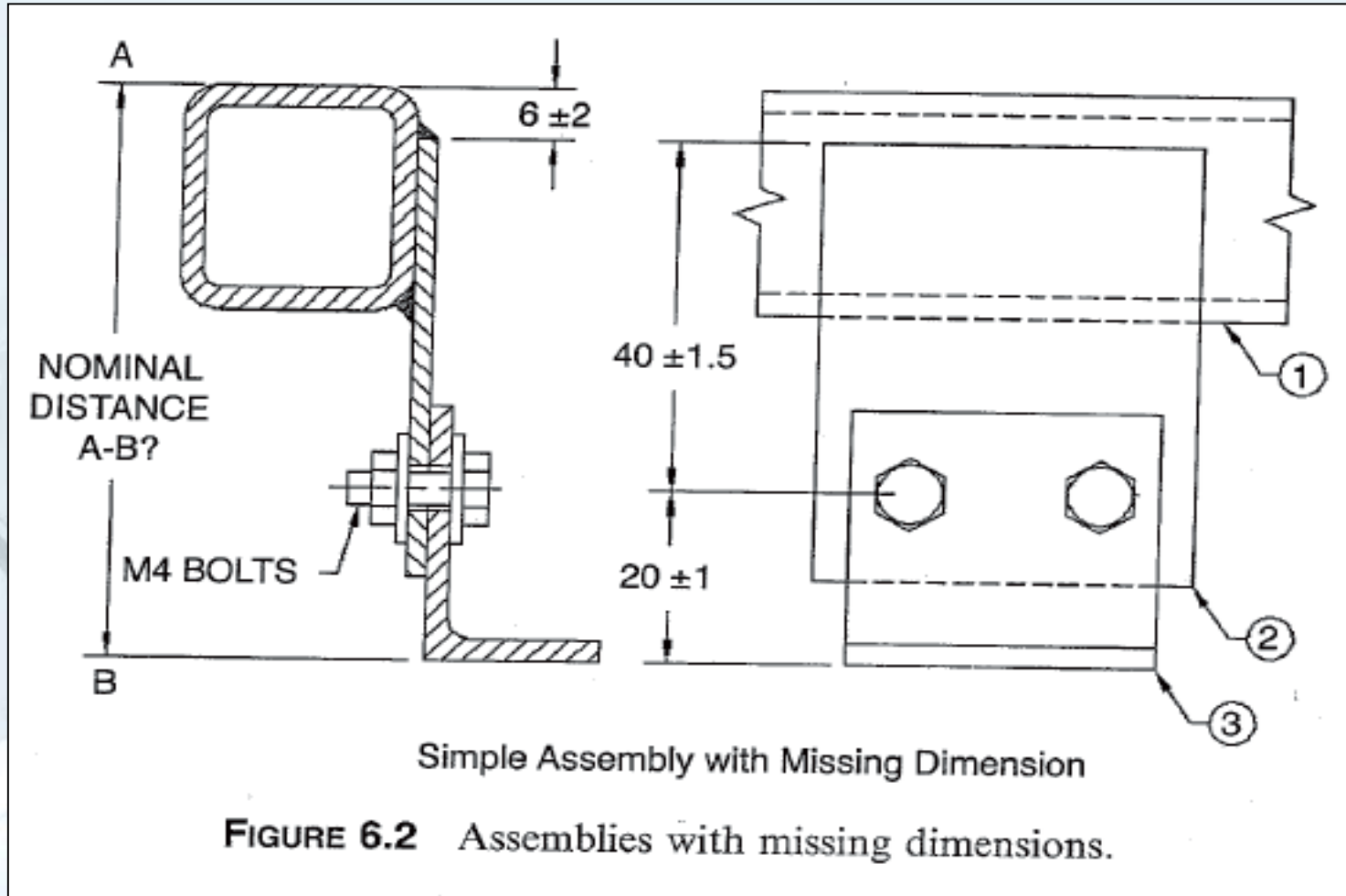

# Chapter #7

QUALITY

## Worst Case Tolerance Stack-up



### Worst-case Tolerance Stack up

1. Select the distance (gap or interference) whose variation is to be determined  
Label one end of the distance A and the other end B (see Fig. 7.1).

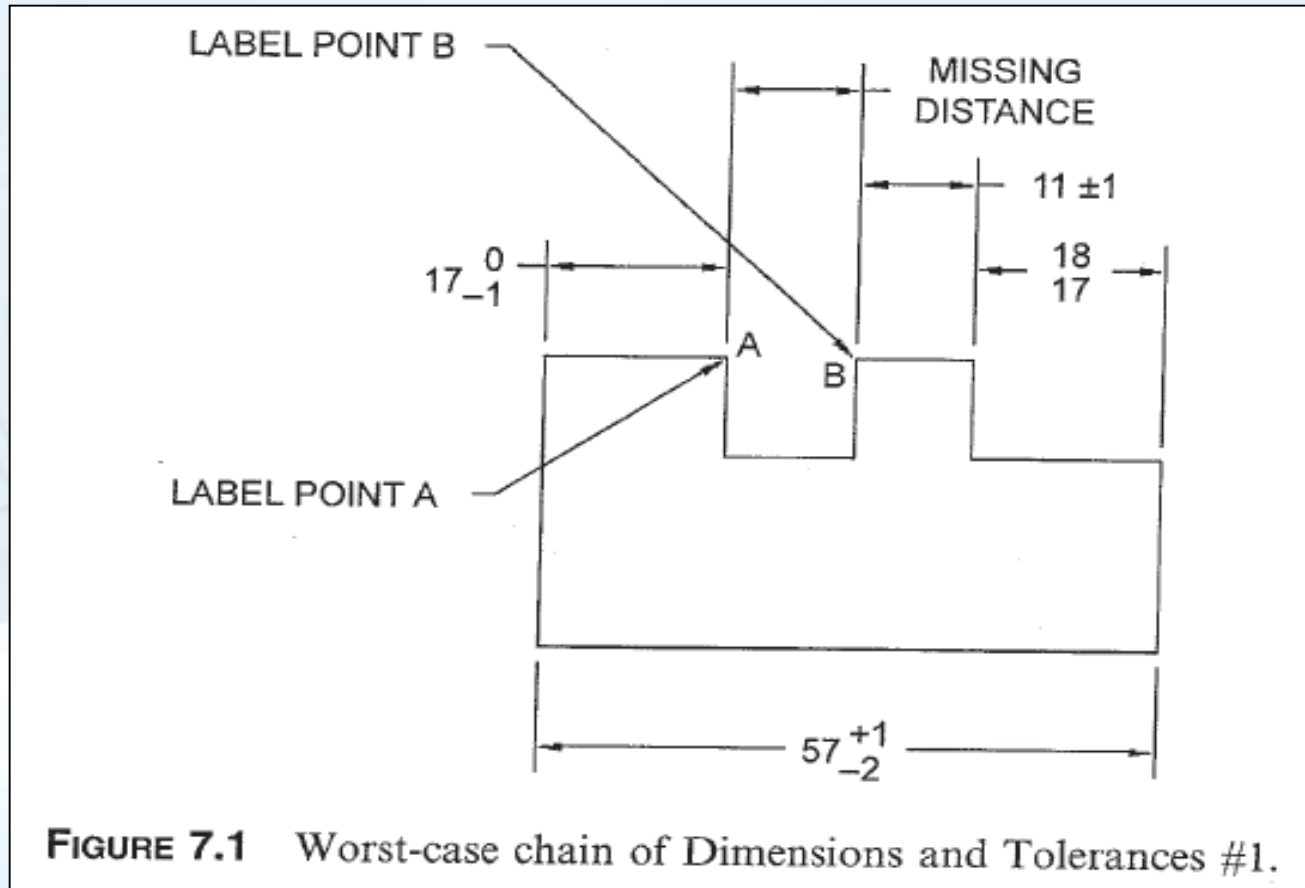

### Worst-case Tolerance Stack up

2. Determine if a one-, two-, or three-dimensional analysis is required.
  - a. two-dimensional analysis: resolved into one dimension using trigonometry
  - b. three-dimensional analysis: a linear Tolerance Stack up is probably not appropriate, and a computer program should be used

### Worst-case Tolerance Stack up With Dimensions

3. Determine a positive direction and a negative direction.

- dimension that spans distance A—B: positive dimension “+”
- dimension that decrease distance A—B: negative dimension “-”

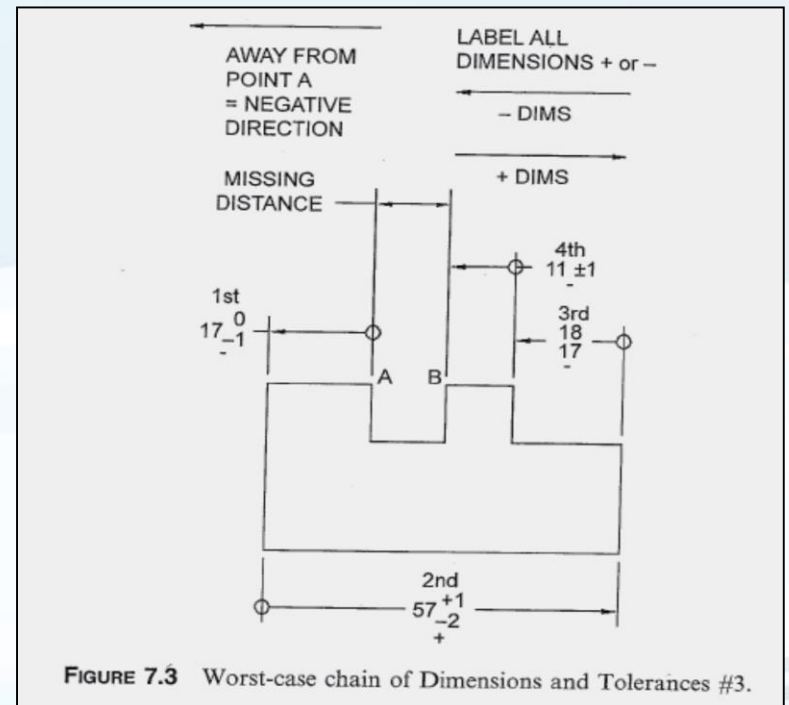
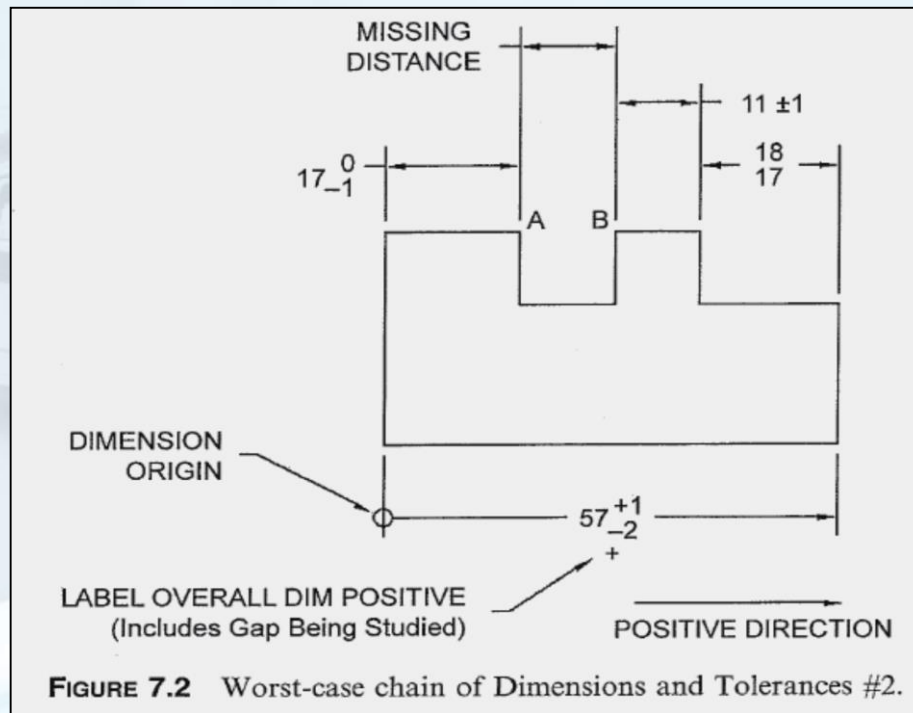



## Worst-case Tolerance Stack up With Dimensions

4. Determine a positive direction and a negative direction.

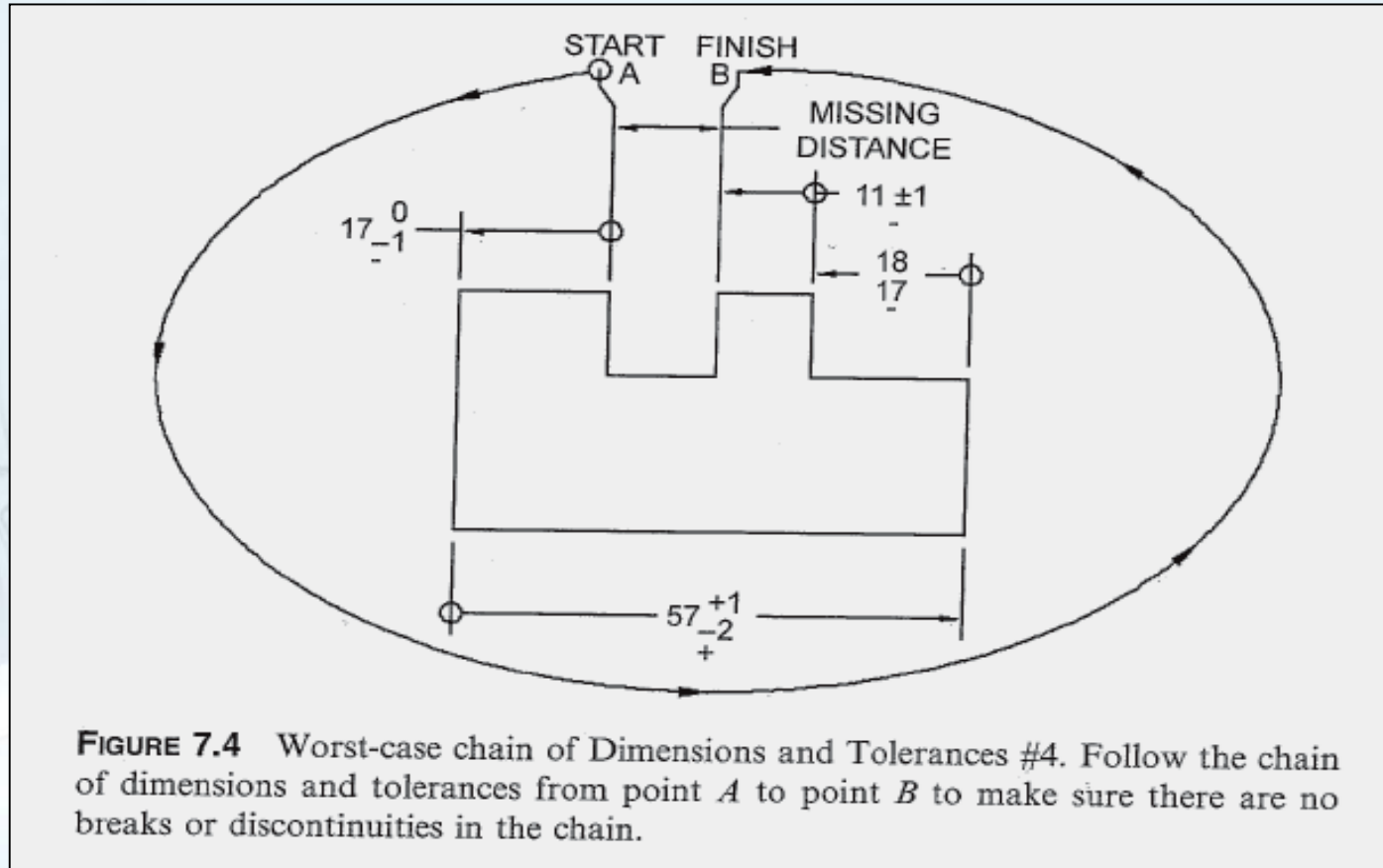

### Worst-case Tolerance Stack up With Dimensions

5. Convert all dimensions and tolerances to equal bilateral format (See Fig. 7.5). Instructions for how to do this are included in Chapter 4

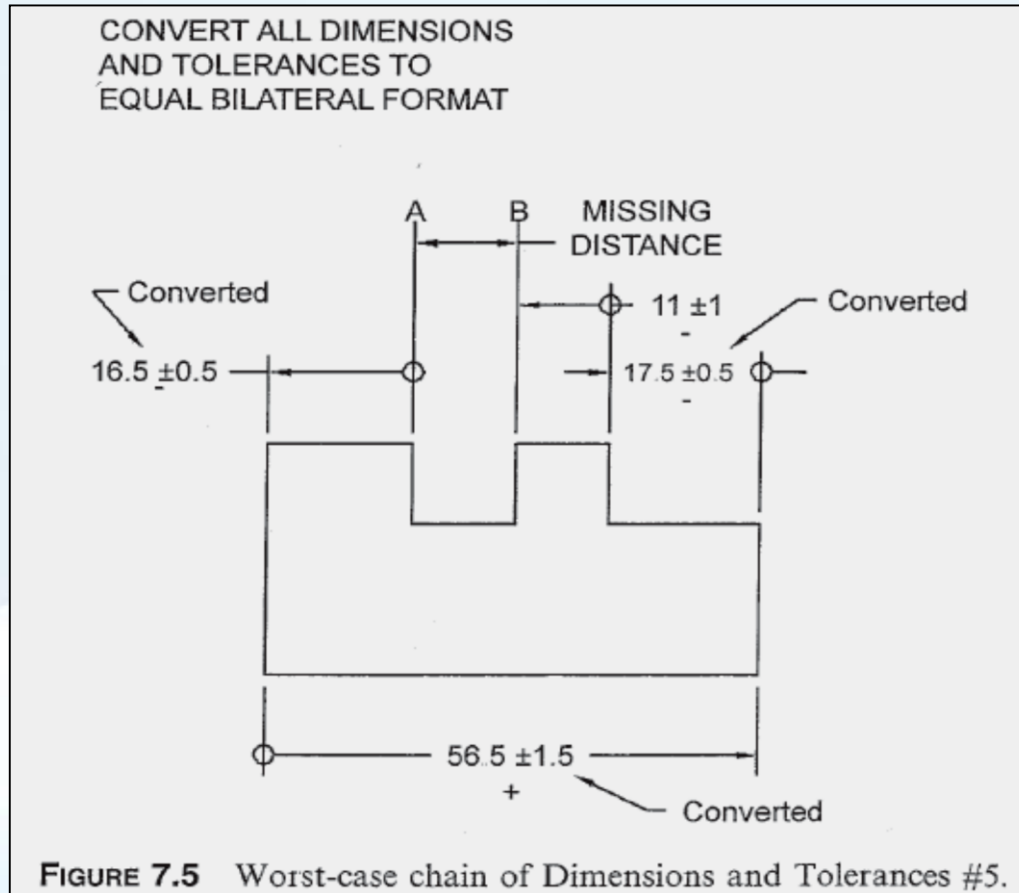

## Worst-case Tolerance Stack up With Dimensions

- all the dimensions and tolerances put into a chart and totaled. Place each positive dimension value in the positive column on a separate line. Place each negative dimension value in the negative column on a separate line. (See Fig. 7.6.)

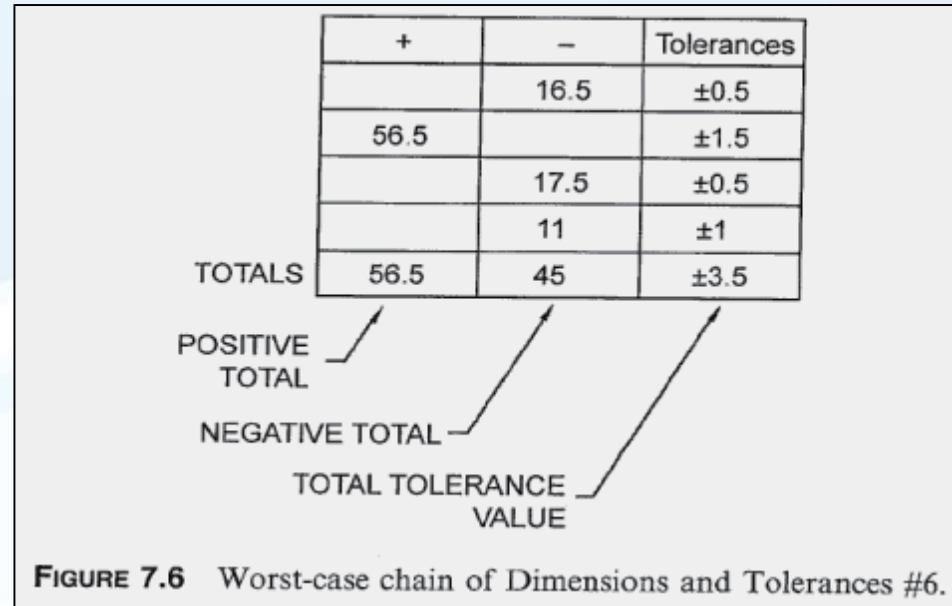
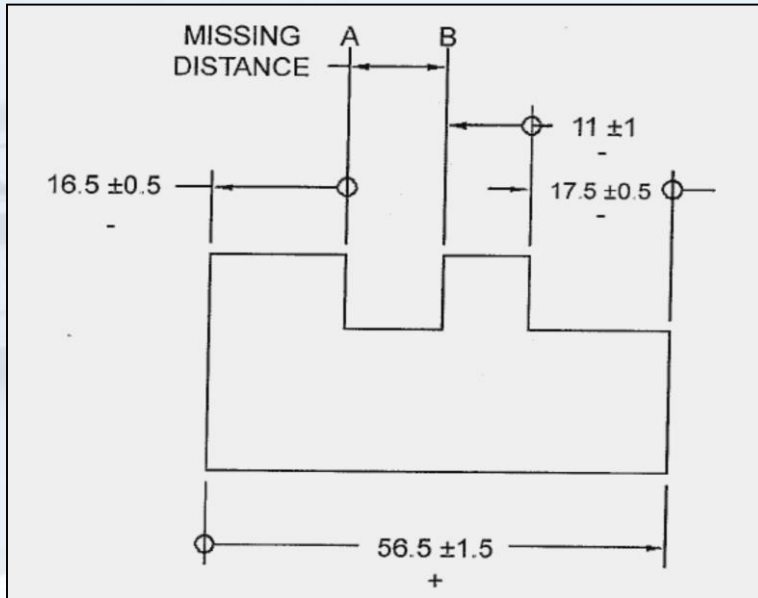

### Worst-case Tolerance Stack up With Dimensions

- Place the tolerance value for each dimension in the tolerance column adjacent to each dimension. This value is half the total variation allowed by the tolerance
- Add the entries in each column, entering the results at the bottom of the chart.

	+	-	Tolerances
		16.5	$\pm 0.5$
	56.5		$\pm 1.5$
		17.5	$\pm 0.5$
		11	$\pm 1$
TOTALS	56.5	45	$\pm 3.5$

POSITIVE TOTAL  $\nearrow$

NEGATIVE TOTAL  $\nearrow$

TOTAL TOLERANCE VALUE  $\nearrow$

**FIGURE 7.6** Worst-case chain of Dimensions and Tolerances #6.

## Worst-case Tolerance Stack up With Dimensions

9. Subtract the negative total from the positive total.

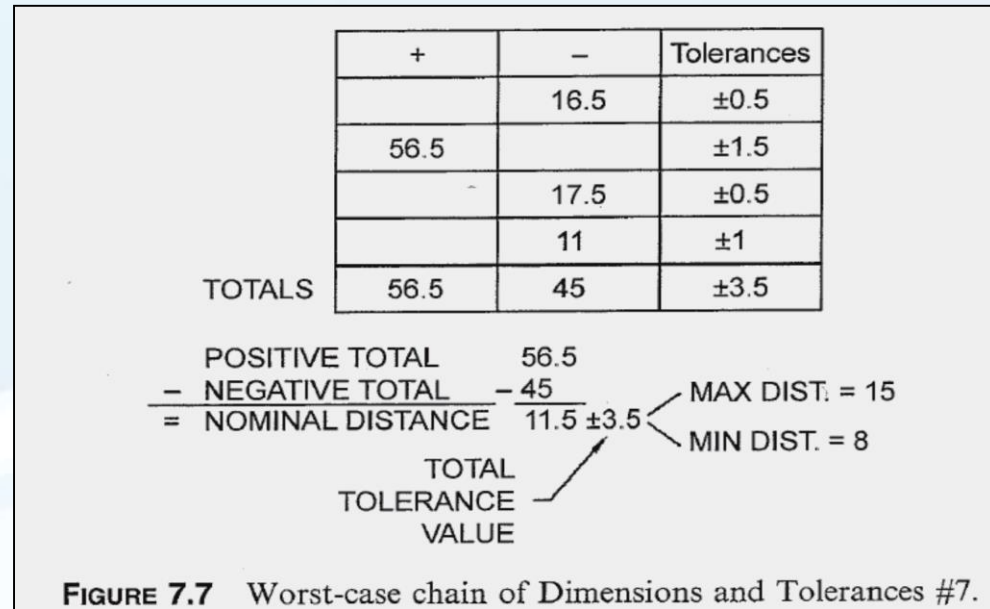
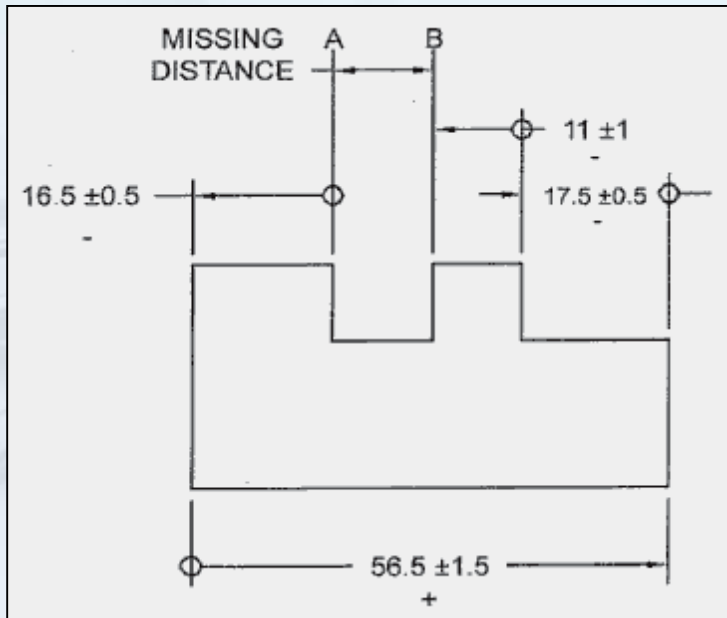

FIGURE 7.7 Worst-case chain of Dimensions and Tolerances #7.

### Assembly Shift

- Assembly shift represents the amount that parts can move during assembly due to the clearance between a hole and a fastener, a hole and a shaft, a width and a slot (like a key and keyway) or between any external feature within an internal feature.
- Assembly shift accounts for the freedom parts have to move from their nominal locations due to the clearance between mating internal and external features at assembly.
- Parts are routinely subjected to forces during assembly: such as gravity



### Assembly Shift

Assembly shift is often overlooked until there is a problem at assembly or until a Tolerance Stack up is performed.

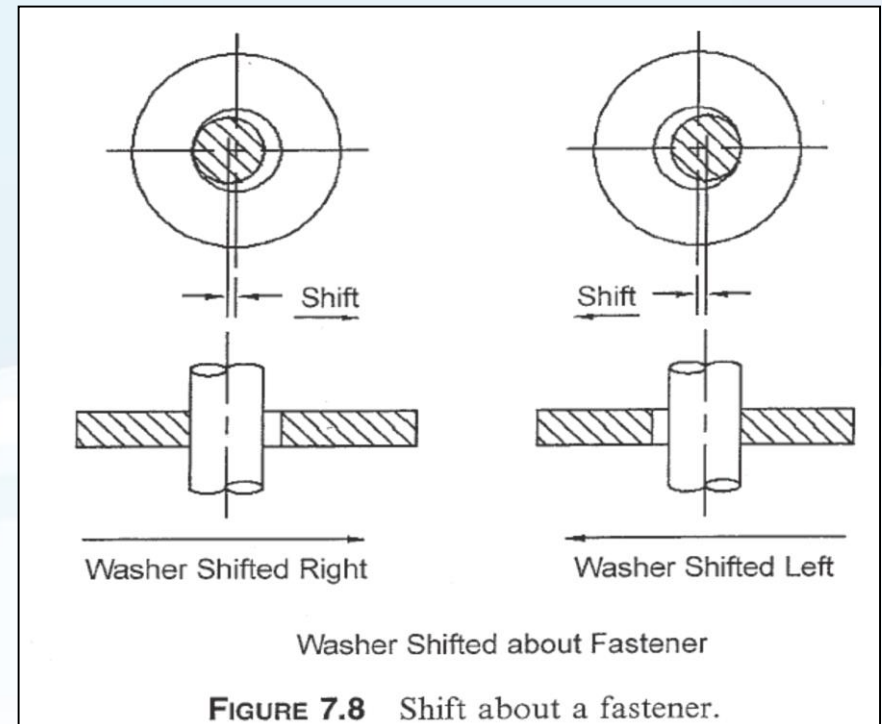
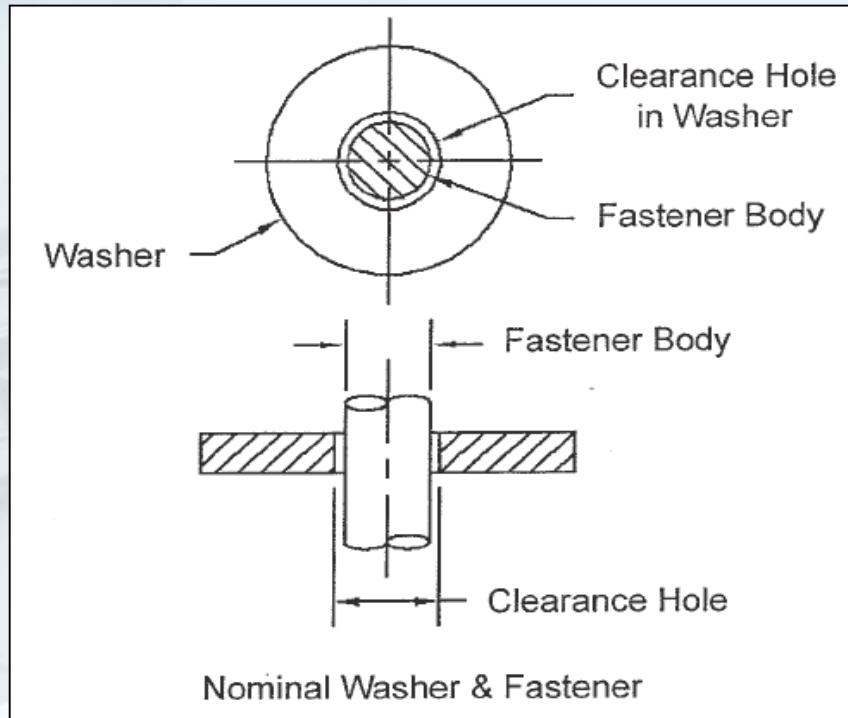

## Assembly Shift – Floating Fastener

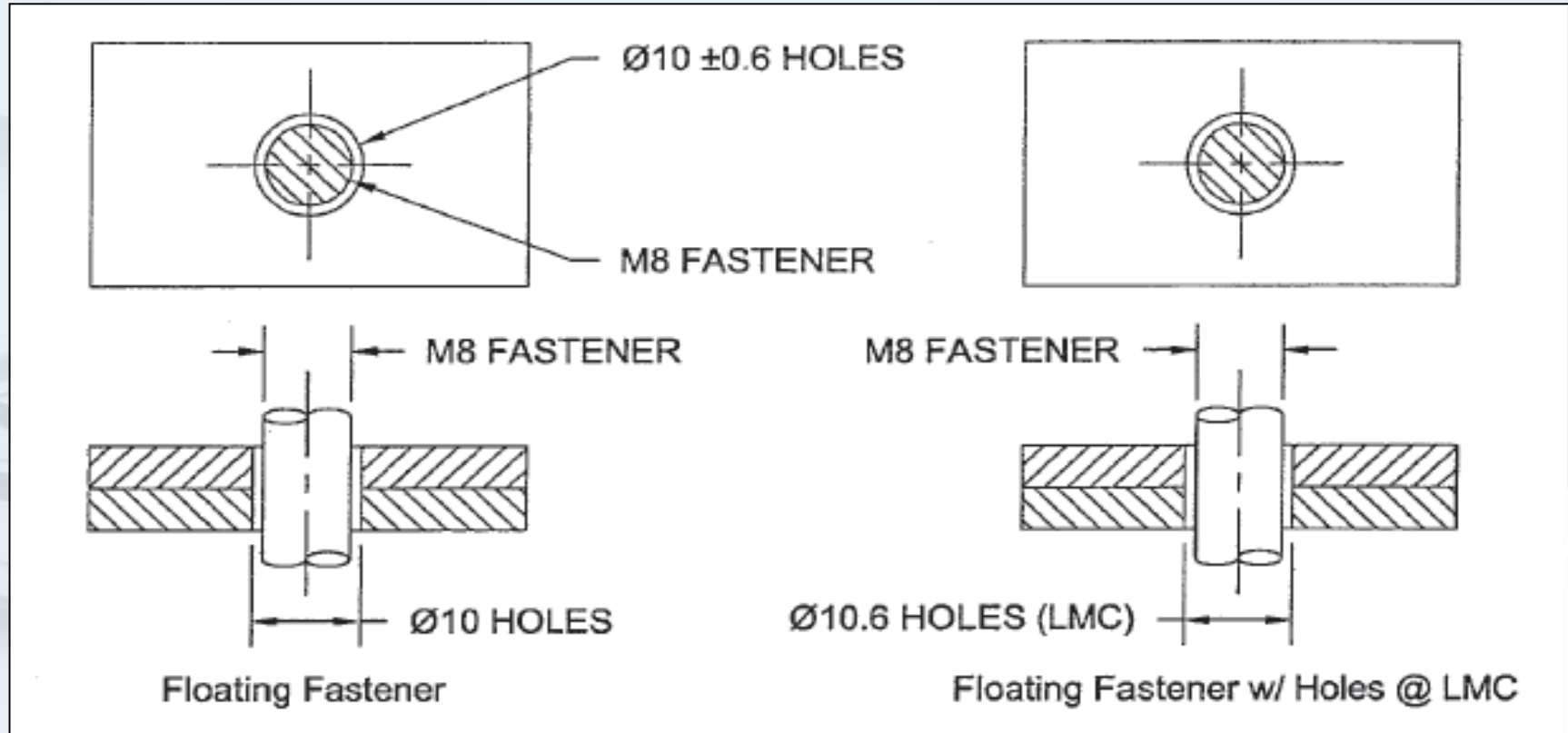

major diameter of the fastener must be used in the Tolerance Stack up. A common shortcut: use the nominal size, exp. 8mm for M8.

## Assembly Shift – Floating Fastener

NOMINAL HOLE Ø	10
+ SIZE TOLERANCE	+0.6
LMC (LARGEST) HOLE Ø	10.6
<hr/>	
LMC (LARGEST) HOLE Ø	10.6
- FASTENER Ø	-8
WORST-CASE ASSEMBLY SHIFT	2.6

Convert to  $\pm$ :  $2.6 / 2 = \pm 1.3$

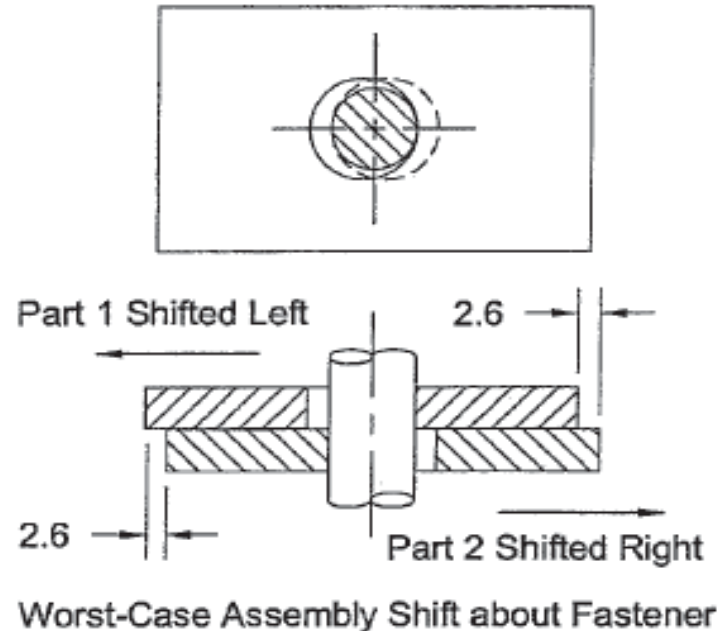

**FIGURE 7.9** Worst-case assembly shift. The Worst-Case Assembly Shift applies to each part. Each part may shift  $\pm 1.3$ mm relative to the fastener, leading to Total Assembly Shift of  $2 * \pm 1.3 = \pm 2.6$ .

Assembly shift is greatest when the hole and the fastener are at their least material conditions (LMC), which are the largest hole and the smallest fastener.

### Rules for Assembly Shift

- In fixed-fastener cases assembly shift is added to the Tolerance Stack up once, representing the amount the clearance holes can shift about the fastener.
- In floating-fastener cases assembly shift is added to the Tolerance Stack up twice, each line representing the amount the clearance holes in each part can shift about the fastener.

The amount each part may shift about the fastener is independent of the mating parts and must be calculated separately.

### Rules for Assembly Shift

- Assembly shift is typically not calculated for fasteners within a threaded hole because fasteners are commonly assumed to self-center within the threaded holes.

there is always some clearance between internal and external threads, and assembly forces do bias the threads at assembly. A simplified approach could be to compare the difference between the pitch diameters of mating male and female threads, which is sometimes called the allowance, and use that value for the assembly shift.

### Rules for Assembly Shift

- In cases where the results of the Tolerance Stack up are very critical and the tolerances are tight, it may be necessary to calculate or estimate the amount that a threaded fastener may move within a threaded hole.
- In cases where oversized holes or slots are used to allow for adjustment at assembly, the assembly shift may be eliminated or even subtracted from the total tolerance. The assembly process will allow time for adjustment, that the assemblers understand the purpose of this extra adjustment, and the parts can be adjusted at assembly, i.e., they are not too heavy or awkward to properly be adjusted to an optimal position.



### Rules for Assembly Shift

- **Adjustment at assembly:**

The parts must be able to be adjusted at assembly if the assembly shift is to be eliminated or subtracted from the total tolerance.

O5M5\$N5E5X

Some parts may be too heavy, too large, too small, too awkward, or difficult to access or see the critical dimension to allow for proper adjustment at assembly. In these cases the assembly shift should be included in the Tolerance Stack up.

This text assumes that there is no adjustment at assembly and that any and all possible assembly shift will show up at final assembly.

Given that premise, each occurrence of assembly shift must be included in the Tolerance Stack up.

## The Role Of Assumptions In Tolerance Stack ups

What's the coaxial relationship? - Not toleranced!

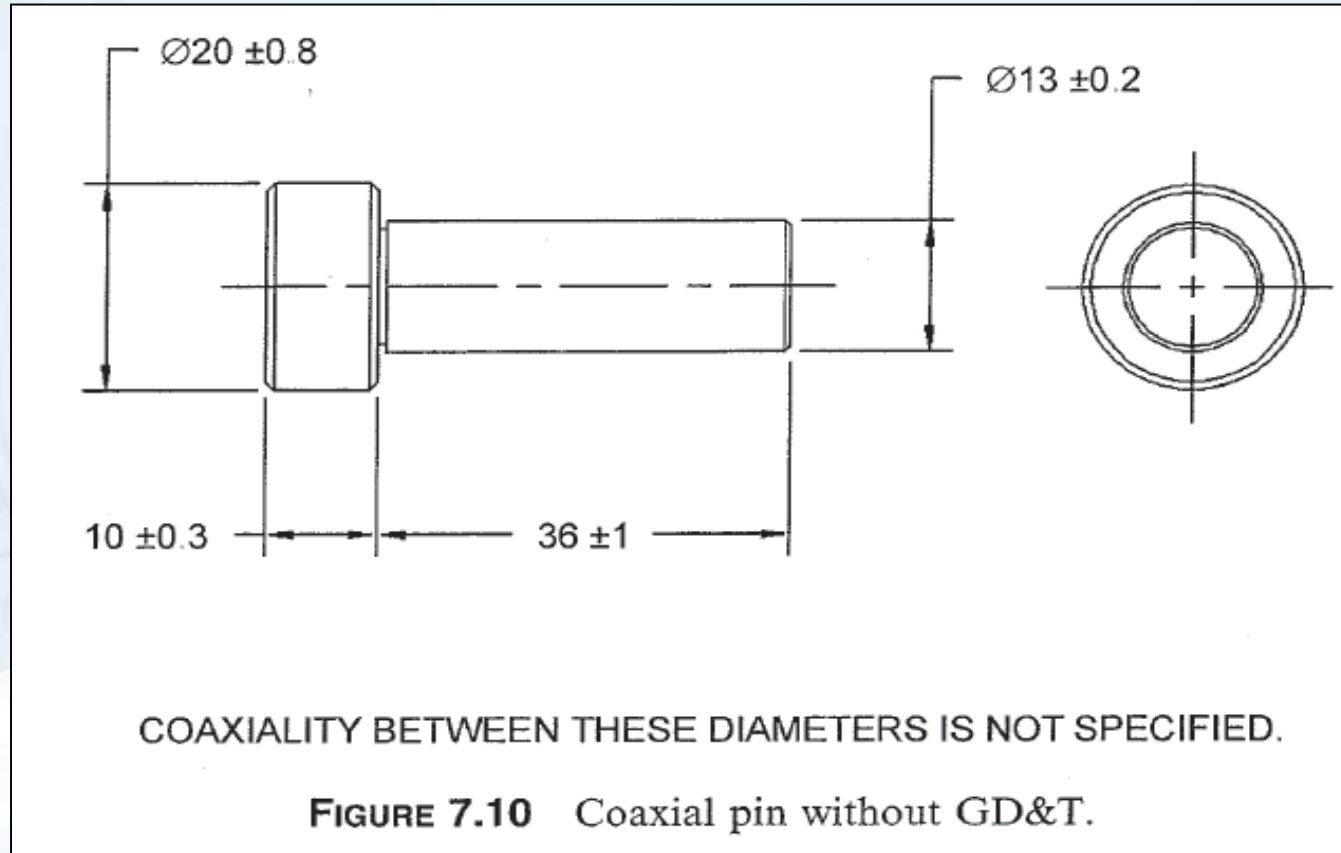

### The Role Of Assumptions In Tolerance Stack ups

- **Framing the problem requires assumptions: idealization**

The Tolerance Analysis techniques presented in this text are for solving one- dimensional, linear Tolerance Stack ups.

All parts are considered in a static state.

The Tolerance Stack up allows parts to shift or rotate relative to one another during assembly, but the study is performed in a static condition.

Typically a worst-case static condition, reflecting worst- case misalignment, minimum clearance, or maximum interference. If desired, statistics may be used to reduce the predicted worst- case total variation.

### The Role Of Assumptions In Tolerance Stack ups

- **Tolerance Stack ups are performed with these considerations:**

If more than one position or orientation of a part must be studied, then a Tolerance Stack up should be done for the considered feature at each important position or orientation.

Tolerance Stack ups are performed at a specified temperature. Unless specified otherwise, Tolerance Stack ups are performed at ambient temperature, the temperature at which the parts are assembled and! or inspected.

If a study is needed to account for differential thermal expansion, then the study should be done at the operating temperature. It may be common in some industries to perform Tolerance Stack ups at a number of temperatures to account for various stages of cooling or heating during operation.

### The Role Of Assumptions In Tolerance Stack ups

- Here parts are assembled at one temperature and operate at a different temperature, it is important to study both conditions, as the parts must be assembled before they can operate.
- Tolerance Stack ups are most accurate when done on parts and assemblies at the temperature at which they were inspected
- Many more assumptions are required for Tolerance Stack ups done at reduced or elevated temperatures
- Catalog parts: it is very common to have no tolerances available on a catalog data sheet. More commonly a detail is included showing the required mating part geometry, typically inadequate from a Tolerance Analysis, such as bearing, bolt, bushing, etc.

Worst-case Tolerance Stack up Examples #7.1

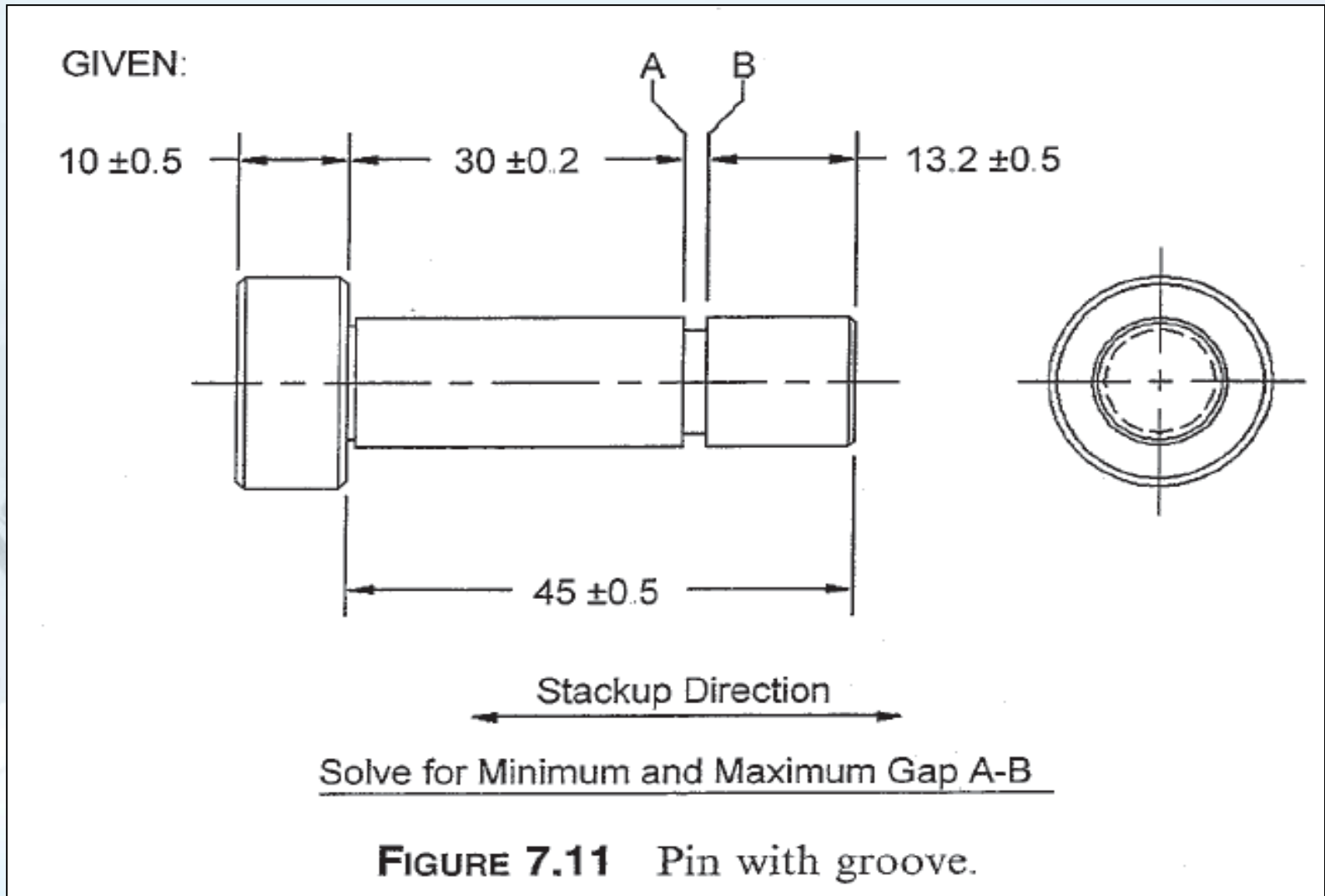



## Chapter #7 Worst Case Tolerance Stack-up

### Worst-case Tolerance Stack up Examples #7.1

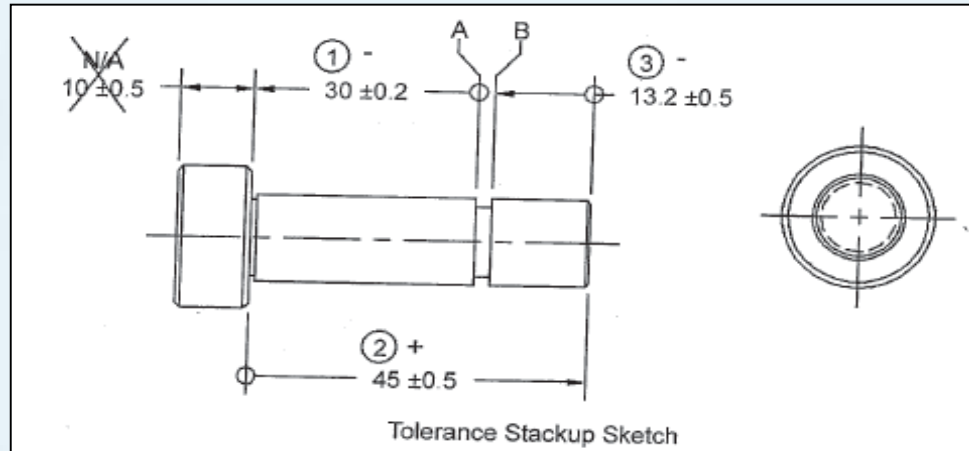

+	-	Tolerances	Description
	30	±0.2	GROOVE - HEAD
45		±0.5	OVERALL LENGTH
	13.2	±0.5	TIP - GROOVE
45	43.2	±1.2	Totals

$$\begin{array}{r}
 \text{Positive Total} \quad 45 \\
 - \text{Negative Total} \quad -43.2 \\
 \hline
 = \text{Nominal Gap} \quad 1.8
 \end{array}
 \quad \pm 1.2$$

Tolerance Value

Stackup Direction

Solve for Minimum and Maximum Gap A-B

FIGURE 7.12 Pin with groove solved.

Worst-case Tolerance Stack up Examples #7.2

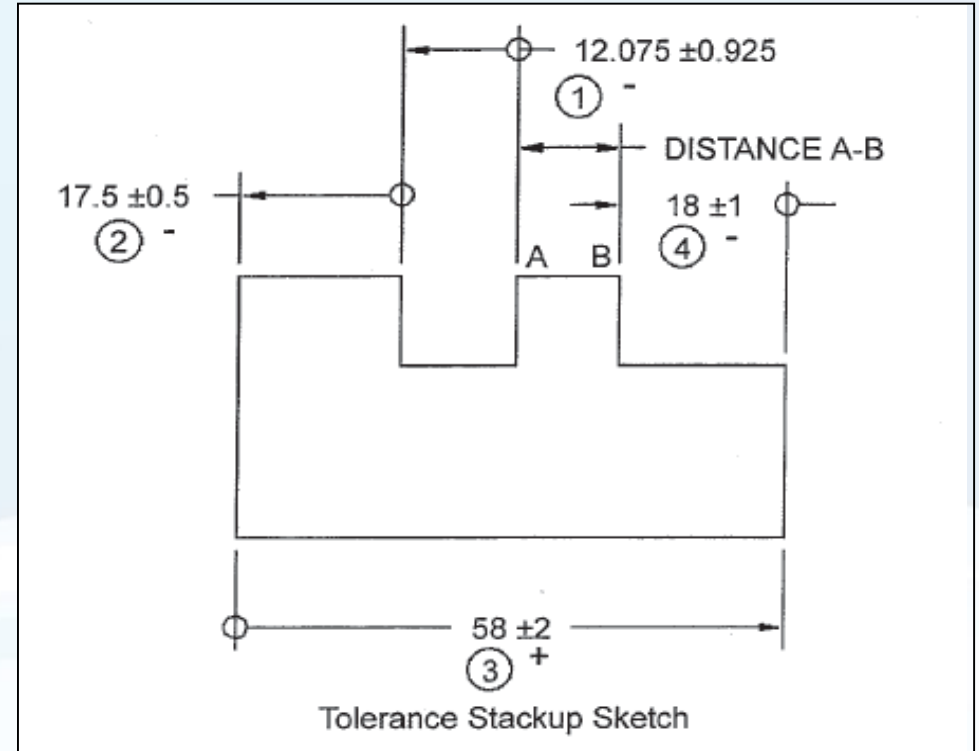
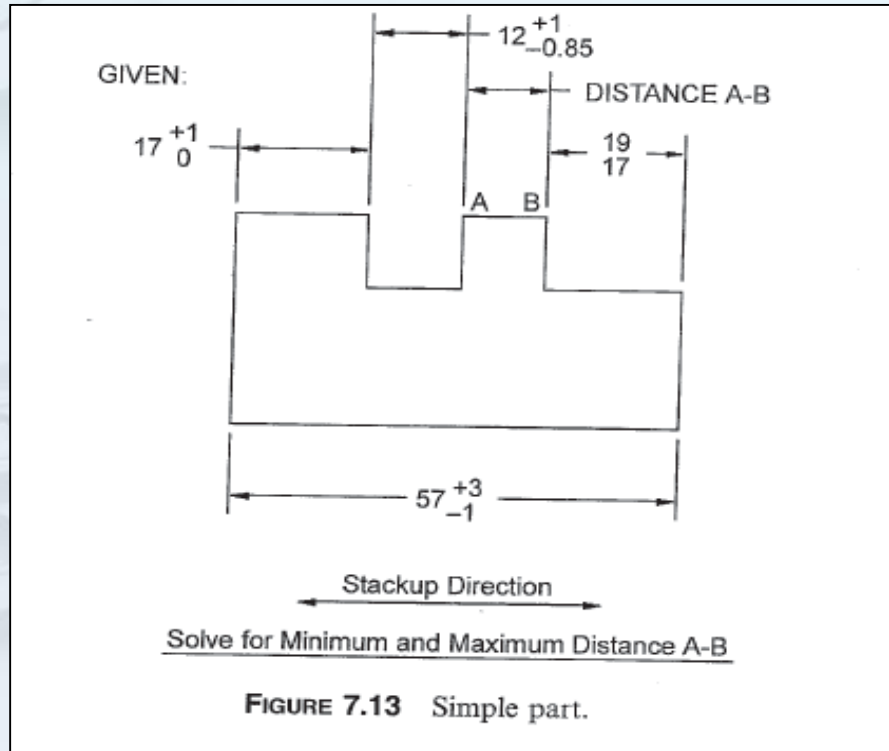

## Worst-case Tolerance Stack up Examples #7.2

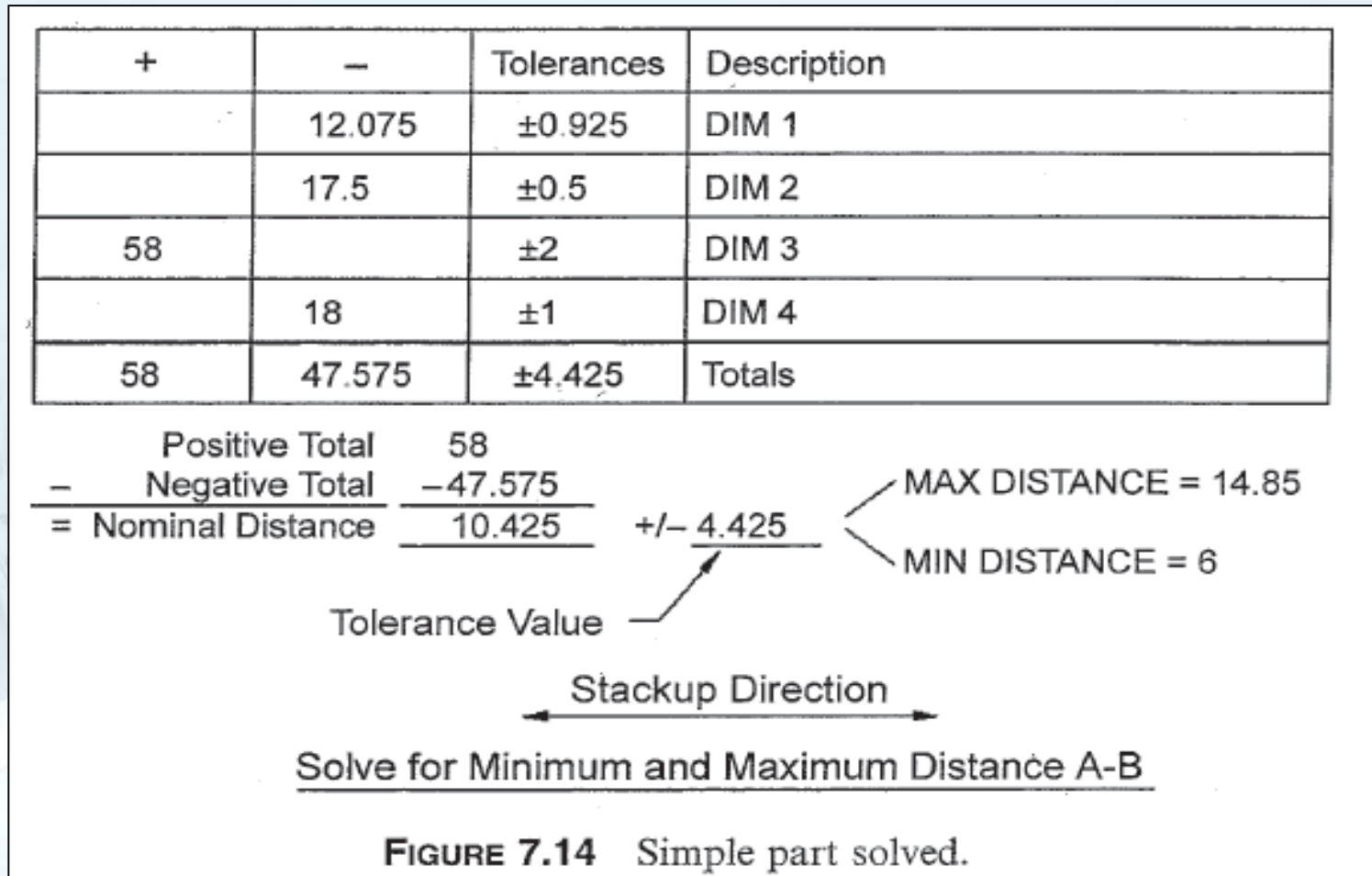

Worst-case Tolerance Stack up Examples #7.3

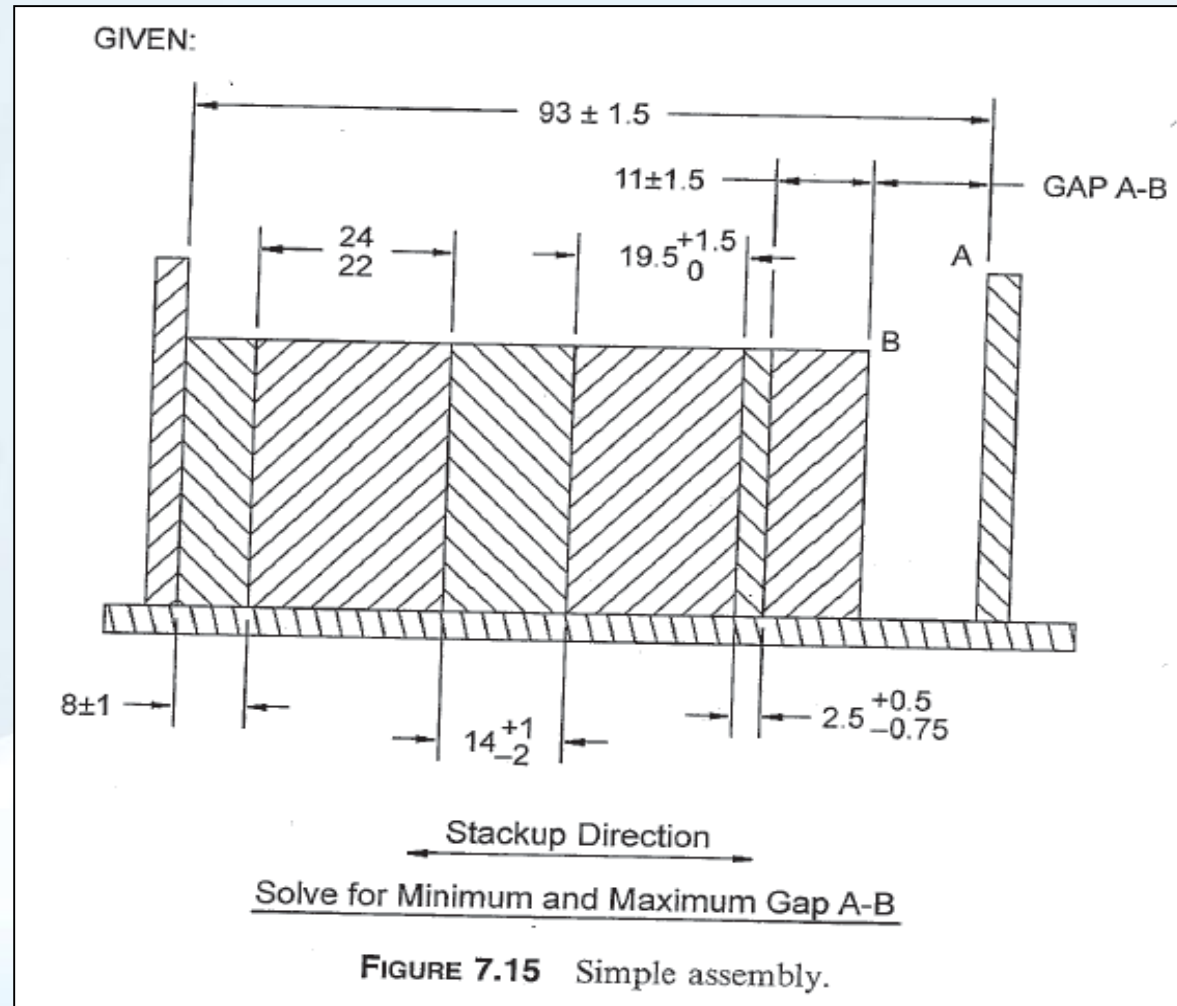

Worst-case Tolerance Stack up Examples #7.3

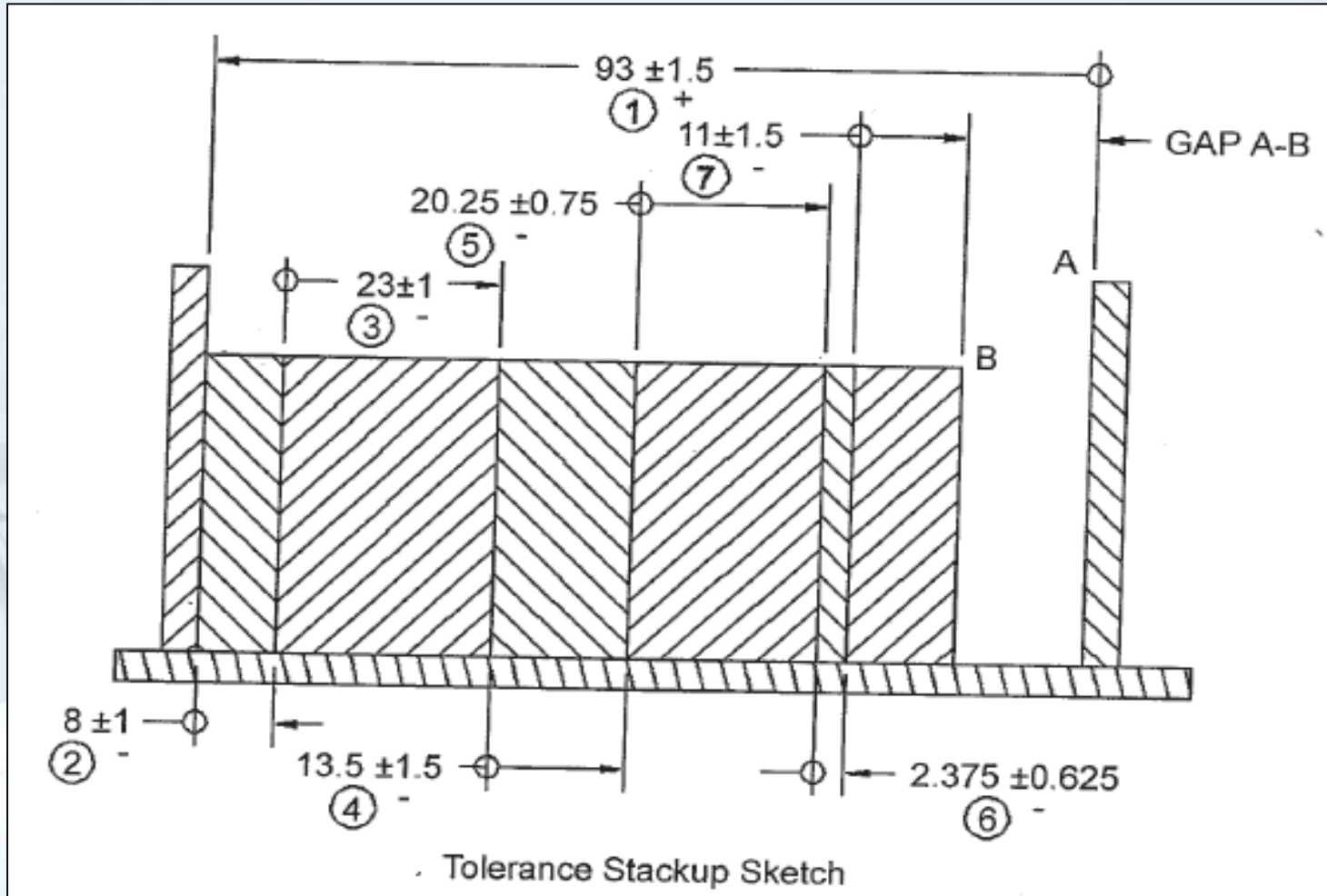

Worst-case Tolerance Stack up Examples #7.3

+	-	Tolerances	Description
93		±1.5	DIM 1
	8	±1	DIM 2
	23	±1	DIM 3
	13.5	±1.5	DIM 4
	20.25	±0.75	DIM 5
	2.375	±0.625	DIM 6
	11	±1.5	DIM 7
93	78.125	±7.875	Totals

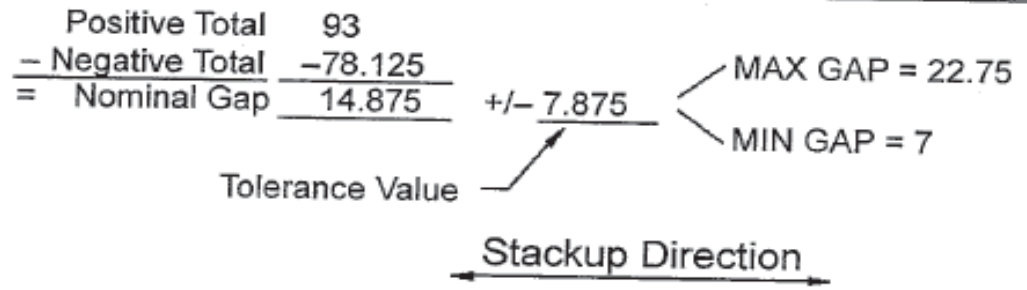

Solve for Minimum and Maximum Gap A-B

FIGURE 7.16 Simple assembly solved.



Worst-case Tolerance Stack up Examples #7.4

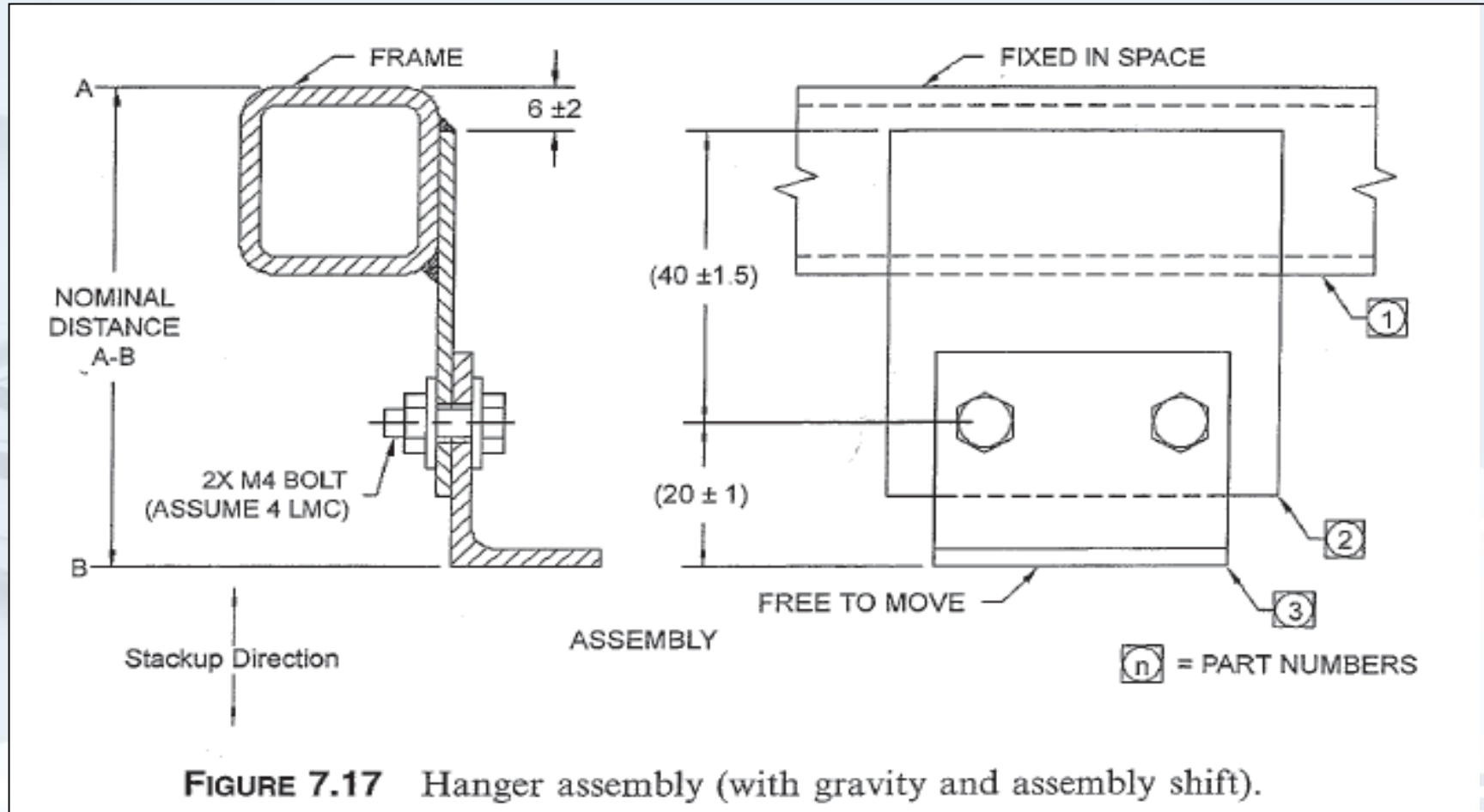

Worst-case Tolerance Stack Up Examples #7.4

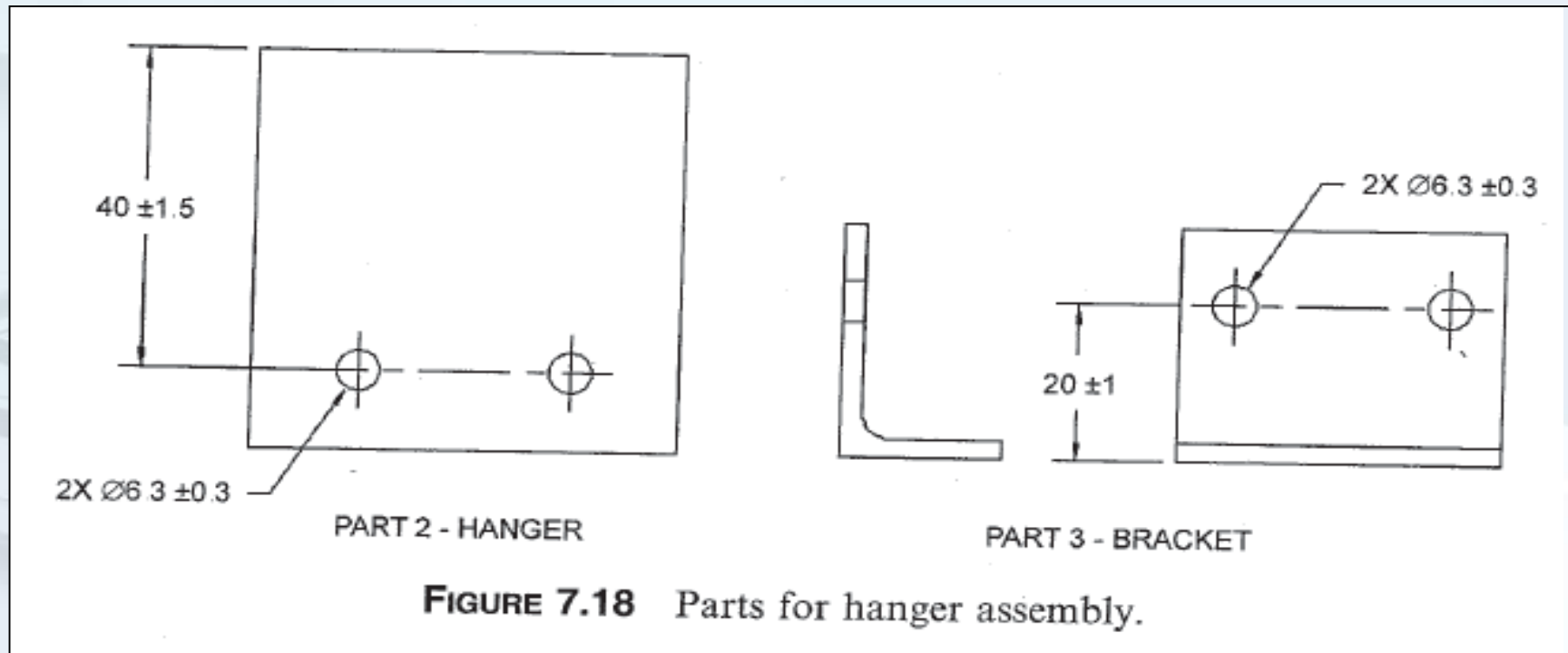

Worst-case Tolerance Stack up Examples #7.4

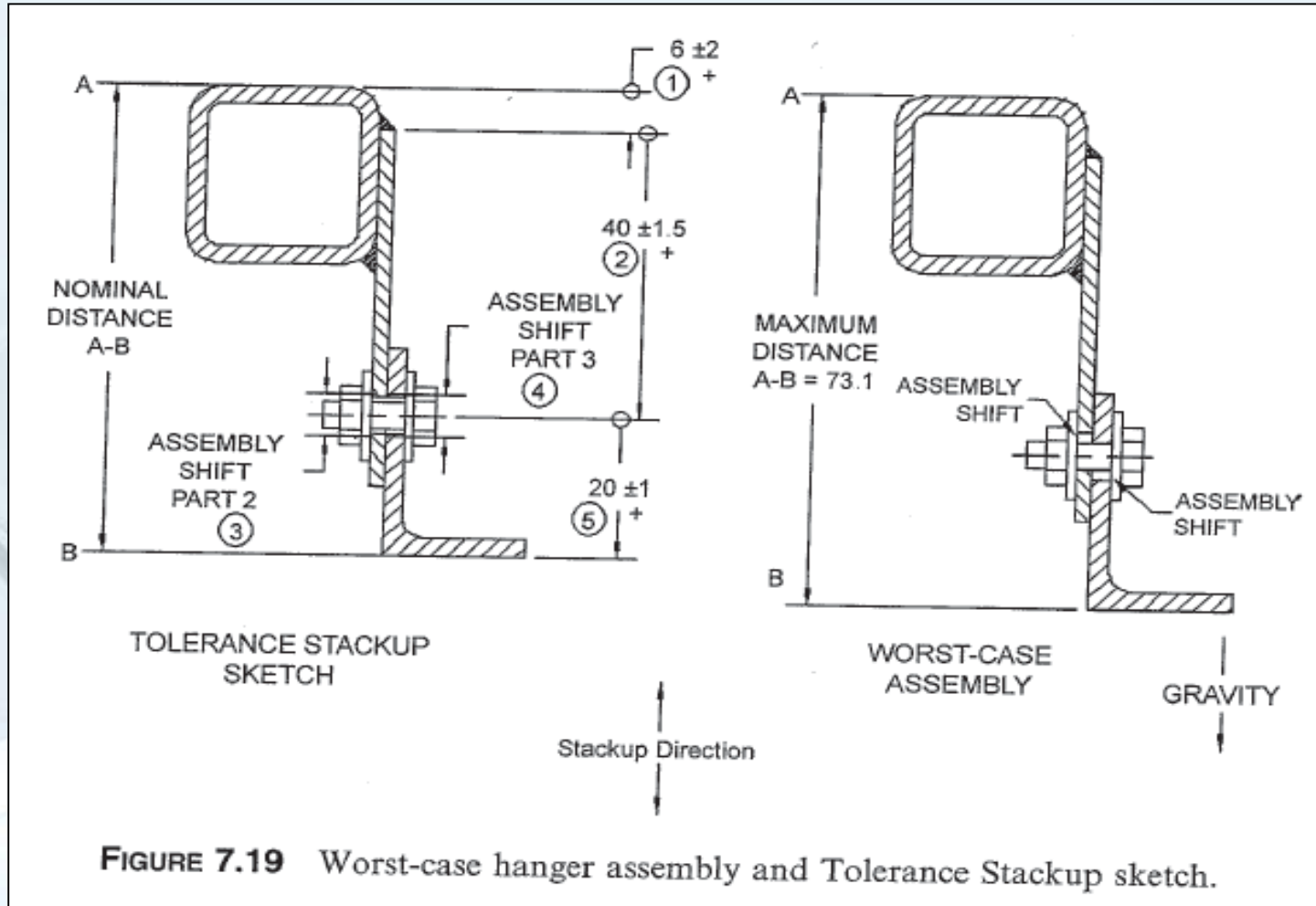

FIGURE 7.19 Worst-case hanger assembly and Tolerance Stackup sketch.

Worst-case Tolerance Stack up Examples #7.4

+	-	Tolerances	Description
6		±2	DIM 1: PART 1 - PART 2
40		±1.5	DIM 2: PART 2 EDGE - HOLES
		±1.3	DIM 3: ASSY SHIFT PART 2: $6.3(H) + 0.3(ST) - 4(F) = 2.6 / 2 = ±1.3$
		±1.3	DIM 4: ASSY SHIFT PART 3: $6.3(H) + 0.3(ST) - 4(F) = 2.6 / 2 = ±1.3$
20		±1	DIM 5: PART 3 HOLES - FLANGE
66	0	±7.1	Totals

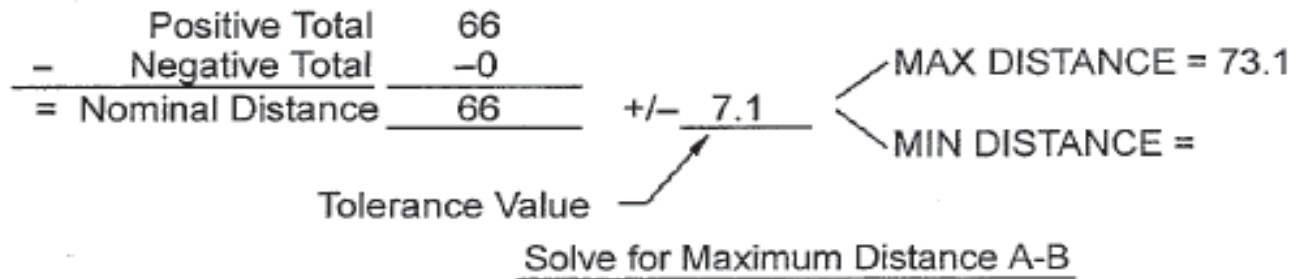

FIGURE 7.20 Tolerance Stackup report solved.



## Worst-case Tolerance Stack up Examples #7.5

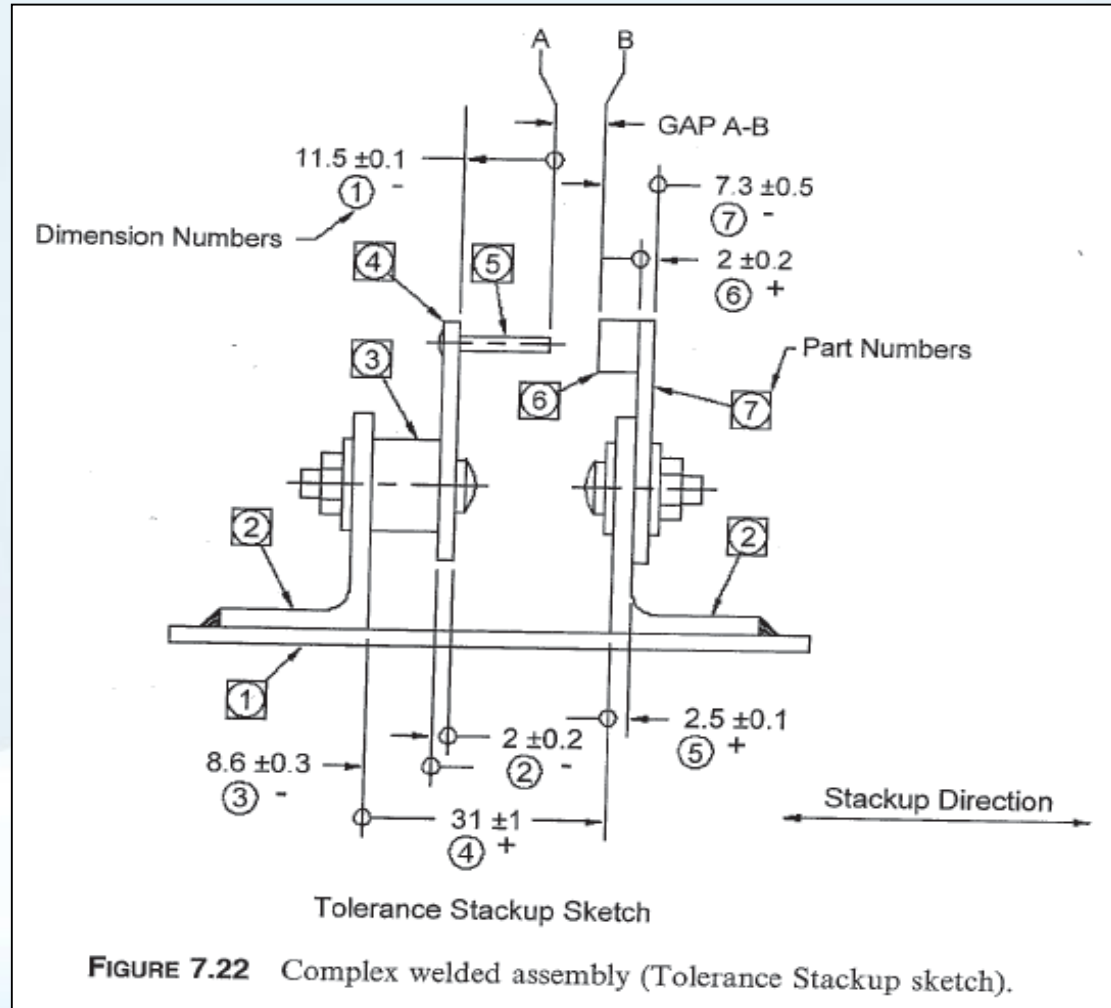
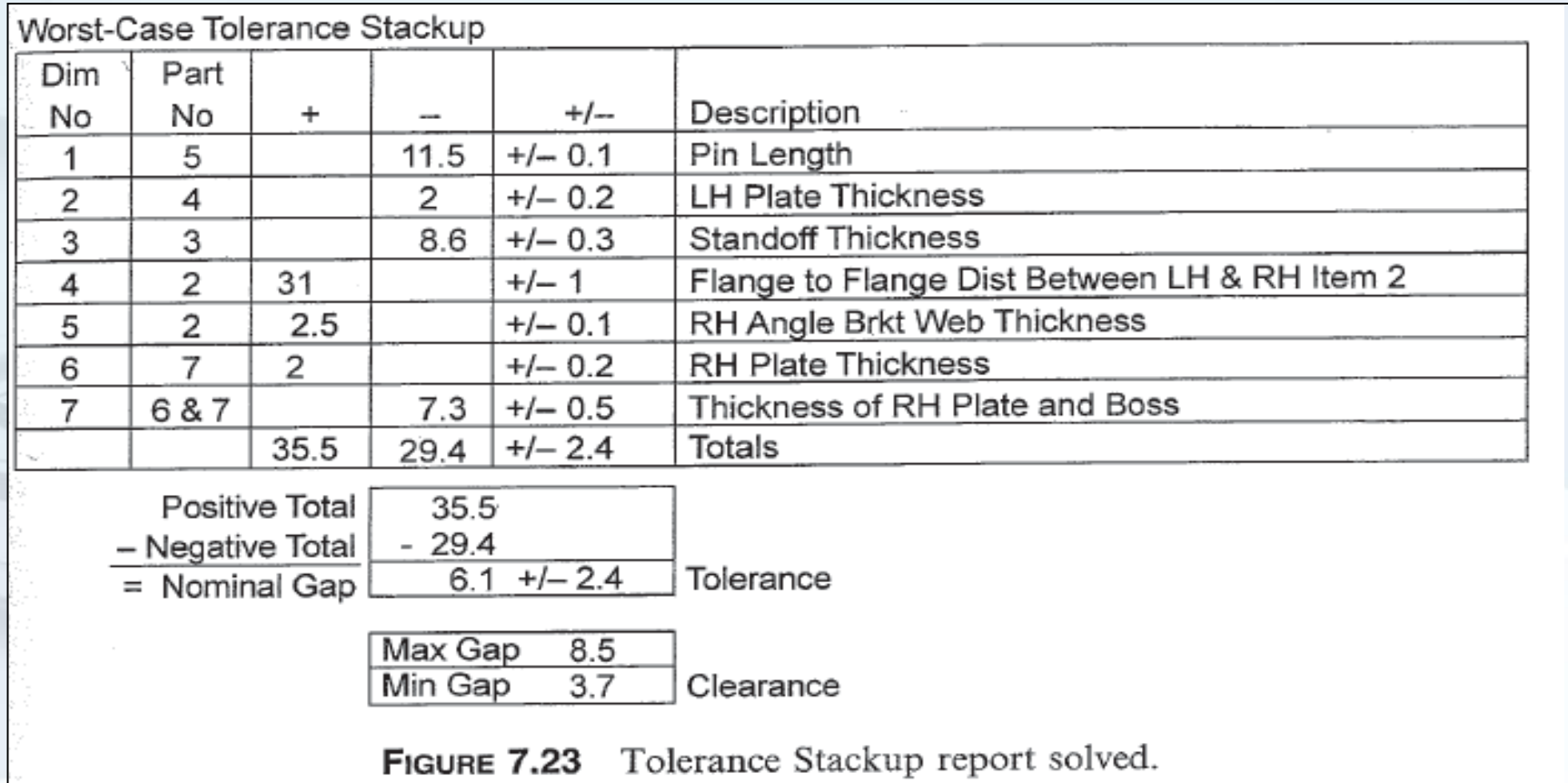

FIGURE 7.22 Complex welded assembly (Tolerance Stackup sketch).



Worst-case Tolerance Stack up Examples #7.5



## Worst-case Tolerance Stack up Examples #7.6

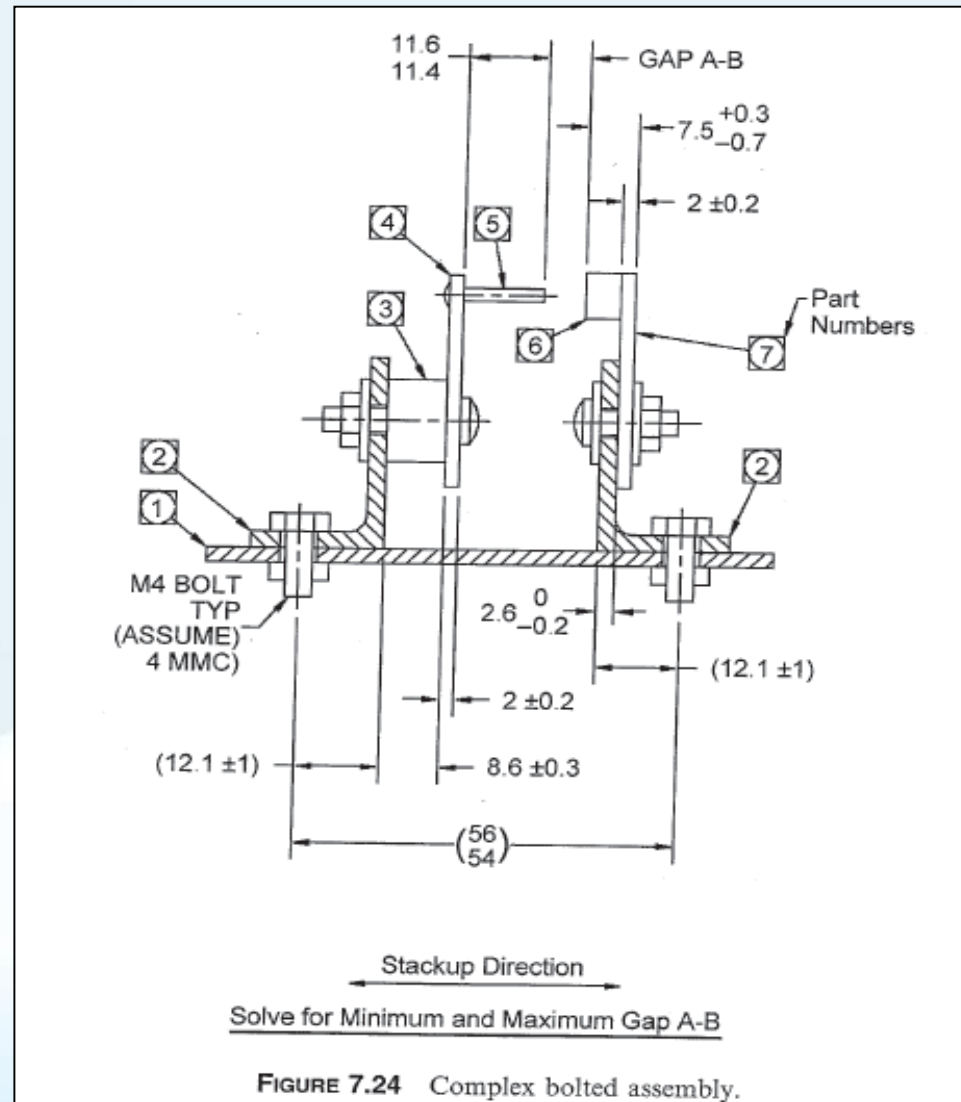
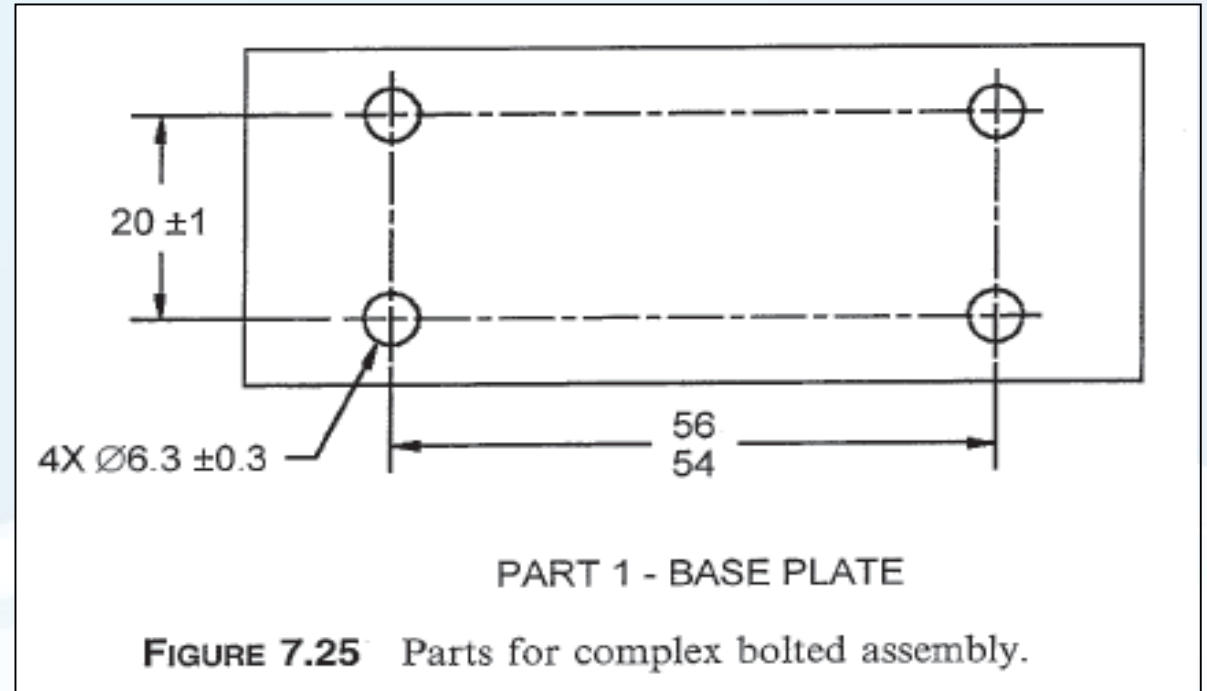
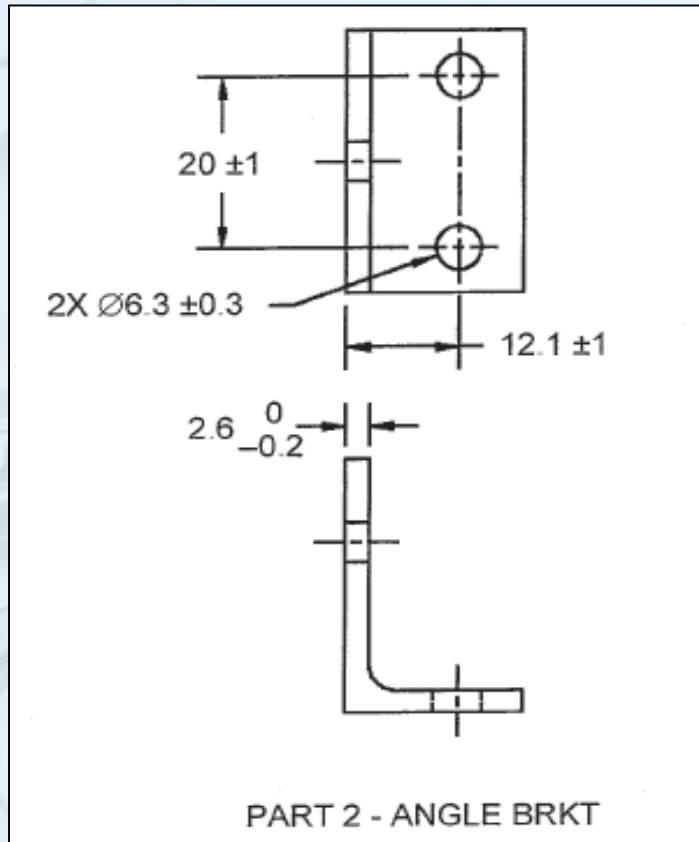
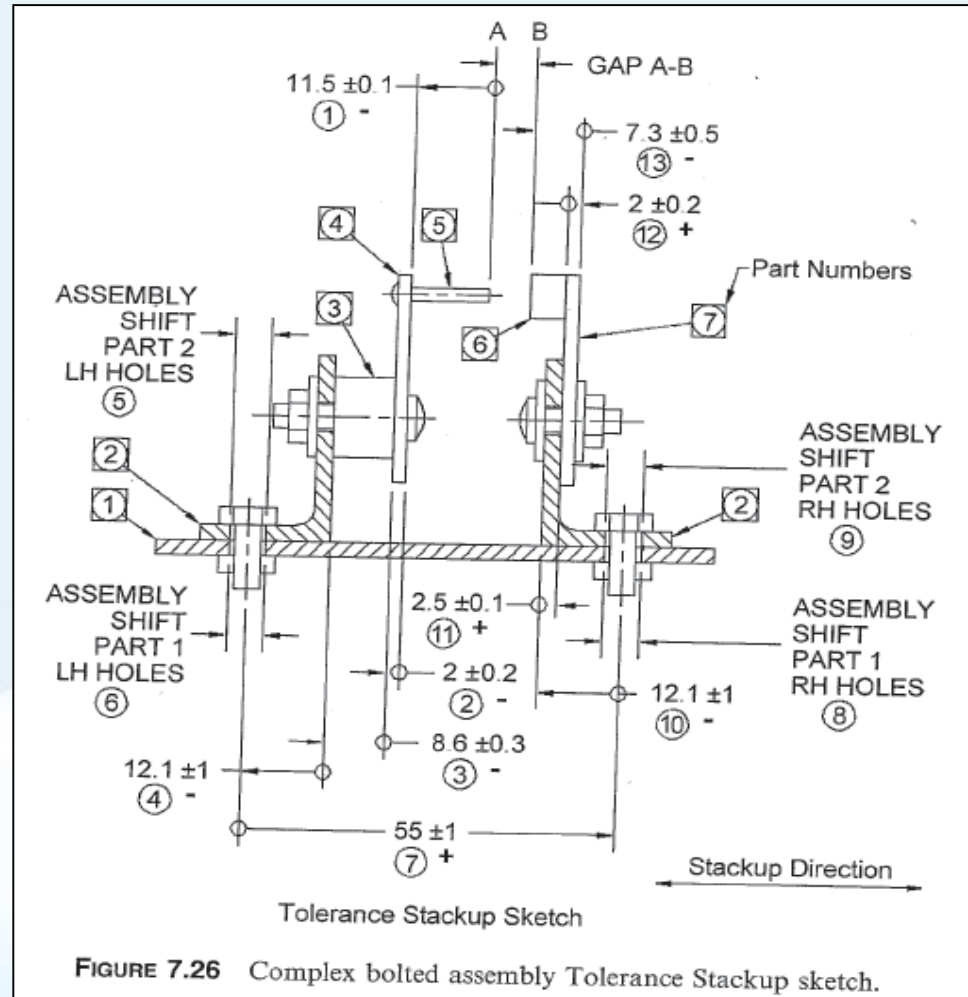

FIGURE 7.24 Complex bolted assembly.

### Worst-case Tolerance Stack up Examples #7.6



## Worst-case Tolerance Stack up Examples #7.6



Worst-case Tolerance Stack up Examples #7.6

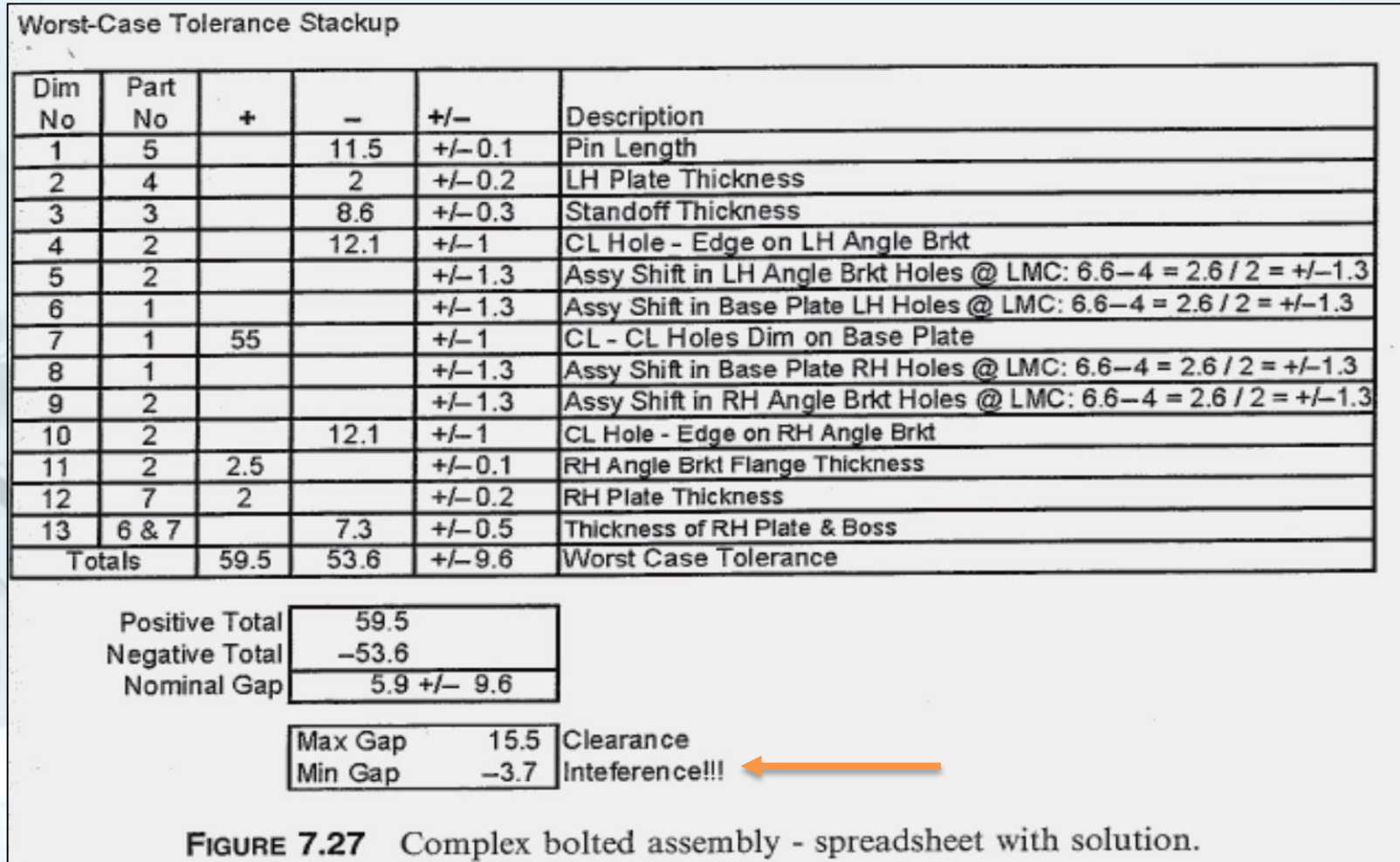



Worst-case Tolerance Stack up Examples #7.6

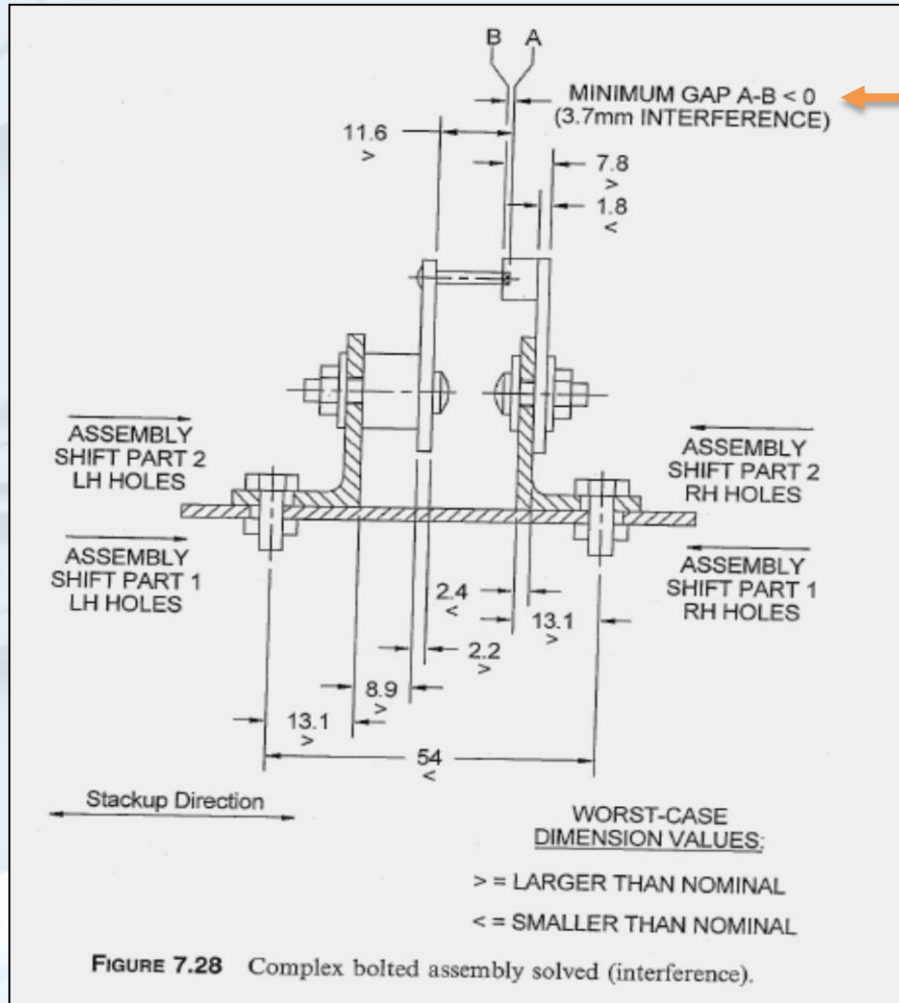

assembly by bolting: More variation than welding assembly  
-3.7



### Tolerance Stack ups And Assemblies

Moving Across an Interface from One Part to the Other in a Tolerance Stack up

Two common types of interfaces encountered in Tolerance Stack ups:

**1. Mating planar surfaces:**

traversing a planar interface (two nominally flat mating surfaces)

**2. clearance holes in mating parts or clearance holes and tapped holes that share common fasteners**

a. traversing a feature-of-size interface, such as coaxial clearance holes in mating parts, or coaxial clearance and threaded holes, with common fasteners

The fixed- and floating-fastener situations described in Chapter 18 are examples of a feature-of-size interface.

### Tolerance Stack ups And Assemblies

- **The guidelines are based on the following assumptions:**

the mating features in the interface are part of the Tolerance Stack up

the dimensions and tolerances contribute to the Tolerance Stack up

they are not directly part of the distance being studied.

the dimension and tolerance values are in the same direction as the Tolerance Stack up direction.

the dimensions and tolerances are in equal bilateral format. If they are not, they must be converted to equal bilateral format.

### Tolerance Stack ups And Assemblies

- **Planar Interface:** Traversing a Planar Interface from One Part to Another in the Tolerance Stack up

For  $\pm$  dimensions and tolerances:

The dimension to the interfacial surface on the first part is included in the Tolerance Stack up.

The  $\pm$  location tolerance associated with the dimension is included in the Tolerance Stack up.

Now the Tolerance Stack up moves from the interfacial surface on the first part to the mating surface on the second part.

Steps 1.a and 1.b are repeated in reverse order for the second part.

### Tolerance Stack ups And Assemblies

- **For GD&T: GD&T**
  - a. If the planar feature is a referenced datum feature:
  - b. The basic dimension to the datum feature is included in the Tolerance Stack up.
  - c. If there is a profile tolerance specified for the datum feature, lines for profile tolerance and datum feature shift are added to the Tolerance Stack up report.

### Tolerance Stack ups And Assemblies

- The values for profile and datum feature shift are entered if the location of the datum feature contributes to the Tolerance Stack up. (The value for datum feature shift may be zero.)
- The values for profile and datum feature shift are set to zero and the lines are marked “N/A” if the location of the datum feature does not contribute to the Tolerance Stack up.
- If the location of the surface does not affect the Tolerance Stack up, but the profile tolerance controls the form of the feature, the profile tolerance may be included in the Tolerance Stack up as described in Chapter 20.

### Tolerance Stack ups And Assemblies

- If the datum feature has a form tolerance, the form tolerance is typically not included in the chain of Dimensions and Tolerances. However, the form tolerance may be included in the Tolerance Stack up per the guidance in Chapter 20 if desired.
- Special cases may require using an orientation tolerance or a lower segment composite profile tolerance in the Tolerance Stack up. These are uncommon applications and must be carefully addressed on a case-by-case basis. For more information see Chapter 9.
- Now the Tolerance Stack up moves from the interfacial surface on the first part to the mating surface on the second part.
- Steps 2.a.i—2.a.iv are repeated in reverse order for the second part.



### Tolerance Stack ups And Assemblies

- **If the planar feature is not a datum feature:**

The basic dimension from the datum reference frame related to the feature is included in the Tolerance Stack up.

Lines for profile and datum feature shift are added to the Tolerance Stack up report. The values for profile and datum feature shift are entered. (The value for datum feature shift may be zero.) (See Chapters 9, 13, and 14.)

### Tolerance Stack ups And Assemblies

- Special cases may require using an orientation tolerance or a lower segment composite profile tolerance in the Tolerance Stack up. These are uncommon applications and must be carefully addressed on a case-by-case basis. For more information see Chapter 9.
- Now the Tolerance Stack up moves from the interfacial surface on the first part to the mating surface on the second part.
- Steps 2.b.i--2.b.iii are repeated in reverse order for the second part.

### Tolerance Stack ups And Assemblies

- **Feature-of-Size Interface:**

Traversing a Feature-of-Size Interface (Mating Clearance and/or Threaded Holes with Common Fasteners) from One Part to Another in the Tolerance Stack up

For  $\pm$  dimensions and tolerances:

The dimension to the Feature of Size on the first part is included in the chain of Dimensions and Tolerances. (This is the dimension in the direction of the Tolerance Stack up where rectangular or polar coordinate dimensioning is used.)

The  $\pm$  location tolerance associated with the dimension is included in the Tolerance Stack up.

### Tolerance Stack ups And Assemblies

- If the features are clearance holes, assembly shift is calculated and added to the chain of Dimensions and Tolerances for the holes in the first part. If the features are threaded or press-fit holes assembly shift is not added.
- Now the Tolerance Stack up moves from the interfacial feature on the first part to the mating feature on the second part.
- Steps 1.a—1.c are repeated in reverse order for the second part.

### Tolerance Stack ups And Assemblies

- **Feature-of-Size Interface:**

#### **GD&T: GD&T**

If the feature of size (hole, pin, etc.) is a referenced datum feature

The basic dimension to the datum feature is included in the Tolerance Stack up.

If a positional or orientation tolerance is specified for the datum feature, lines for the positional/orientation tolerance, bonus tolerance, and datum feature shift are added to the Tolerance Stack up report.

### Tolerance Stack ups And Assemblies

- **Feature-of-Size Interface:**

**GD&T:**

The values for position/orientation, bonus tolerance, and datum feature shift are entered if the location of the datum feature contributes to the Tolerance Stack up. (The values for bonus tolerance and datum feature shift may be zero.) (See Chapter 9.)

The values for position/orientation, bonus tolerance, and datum feature shift are set to zero and the lines are marked “N/A” if the location of the datum feature does not contribute to the Tolerance Stack up. (This is common where the datum feature of size is the primary or secondary datum feature in a referenced feature control frame.) (See Chapters 9, 13, and 14.)



### Tolerance Stack ups And Assemblies

- **Feature-of-Size Interface:**

**GD&T:**

Assembly shift is calculated and added to the chain of Dimensions and Tolerances for the datum feature of size in the first part. Assembly shift is typically not added if the datum features of size are threaded holes.

Now the Tolerance Stack up moves from the datum feature on the first part to the datum feature on the second part.

Steps 2.a.i—2.a.iii are repeated in reverse order for the second part.

### Tolerance Stack ups And Assemblies

- **Feature-of-Size Interface:**

**GD&T:**

If the feature of size (hole, pin, etc.) is a not a datum feature:

The basic dimension from the datum reference frame related to the feature is included in the Tolerance Stack up.

Lines for positional tolerance, bonus tolerance, and datum feature shift are added to the Tolerance Stack up report. The values for position, bonus tolerance, and datum feature shift are entered. (The values for bonus tolerance and datum feature shift may be zero.) (See Chapters 9, 13, and 14.)

### Tolerance Stack ups And Assemblies

- **Feature-of-Size Interface:**

#### **GD&T:**

If the feature of size (hole, pin, etc.) is not a datum feature:

Assembly shift is calculated and added to the chain of Dimensions and Tolerances for the holes in the first part. Assembly shift is typically not added if the features of size are threaded holes.

Now the Tolerance Stack up moves from the interfacial feature on the first part to the mating feature on the second part.

Steps 2.b. 1—2..b.iii are repeated in reverse order for the second part.

# Chapter #8

QUALITY

## Statistic Tolerance Stack-up



### Statistical Tolerance Stack ups

- Statistical Tolerance Stack ups determine the probable or likely maximum variation possible for a selected dimension.
- realistically assumes that it is highly improbable that all the dimensions in the Tolerance Stack up will be at their worst-case low limit or high limit at the same time.
- The sum of the dimensions and tolerances will likely approximate a normal distribution.
- Most or all of the dimensions will likely be closer to their nominal value than either extreme. Also, some of the dimensions that the worst-case model required to be at their upper limit may actually be closer to their lower limit, and vice versa. The combination of these factors leads to the idea of a statistical Tolerance Stack up.

### Statistical Tolerance Stack ups

- when it is appropriate to use a statistical versus a worst-case Tolerance Stack up.
- depends on a number of factors, including the number of tolerances in the Tolerance Stack up, the quantity of parts to be manufactured, manufacturing process controls, design sensitivity, past company practices, and willingness to accept risk, to name a few.
- A simple rule of thumb is as the number of tolerances in a Tolerance Stack up increases, the benefits and validity of using a statistical analysis increases.



### Statistical Tolerance Stack ups Assumption

- **Statistical tolerance analyses are based on several conditions being in place.**

#### **These include::**

The manufacturing processes for the parts must be controlled processes. This requires, among other things, that manufacturing nominal is the same as design nominal.

Processes must be centered and output normal or gaussian distributions (see Fig. 8.1). This presents a problem where unequal bilateral or unilateral tolerances have been specified.

Parts must be randomly selected for assembly.

### Statistical Tolerance Stack ups Assumption

- The design must be able to tolerate the possibility that some small percentage of the as-produced parts or assemblies exceed the calculated statistical result.
- The enterprise must be willing to tolerate the possibility that some parts or assemblies will be rejected due to exceeding the calculated statistical result.

## Statistical Tolerance Analyses

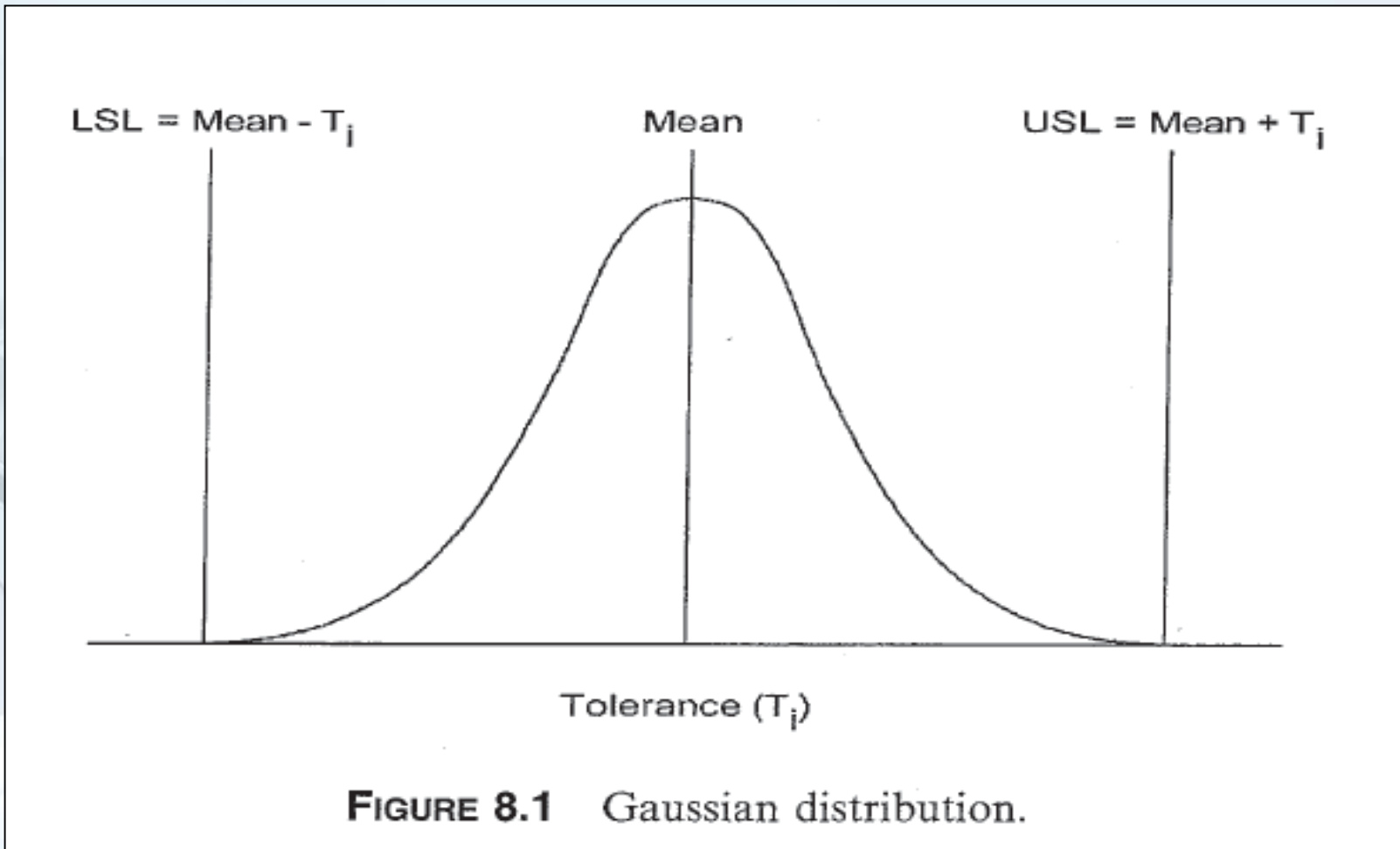

**FIGURE 8.1** Gaussian distribution.

## Statistical Tolerance Analyses

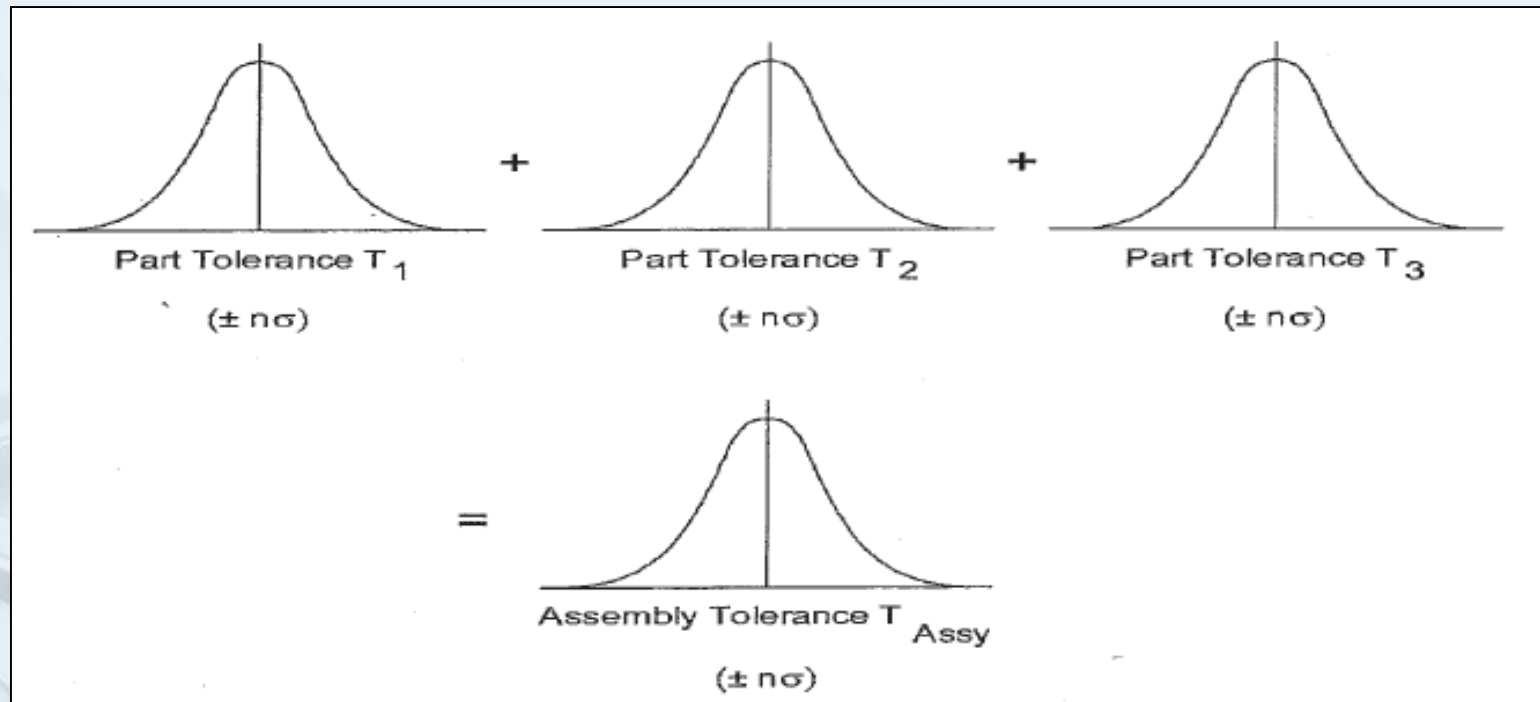

$$\text{RSS Tolerance} = \sqrt{T_1^2 + T_2^2 + T_3^2 \dots + T_n^2}$$

**FIGURE 8.2** Root sum formula for statistical Tolerancing. Where:  $T_n$  = Tolerances in the Tolerance Stackup.

# Statistical Tolerance Analyses

- **Two statistical methods for Tolerance Analysis:**
- **Root-sum-square (RSS)**  
Root-sum-square is commonly used on manually modeled and spreadsheet-based statistical Tolerance Stack ups.
- **Monte Carlo simulations**  
Monte Carlo simulation is typically used with computer-based Tolerance Analysis simulation software. Simply put, Monte Carlo simulations take all the variables in a Tolerance Stack up, give them a random value within their range, derive a result, iterate this process thousands of times, and average the result.

## Statistical Tolerance Analyses Case

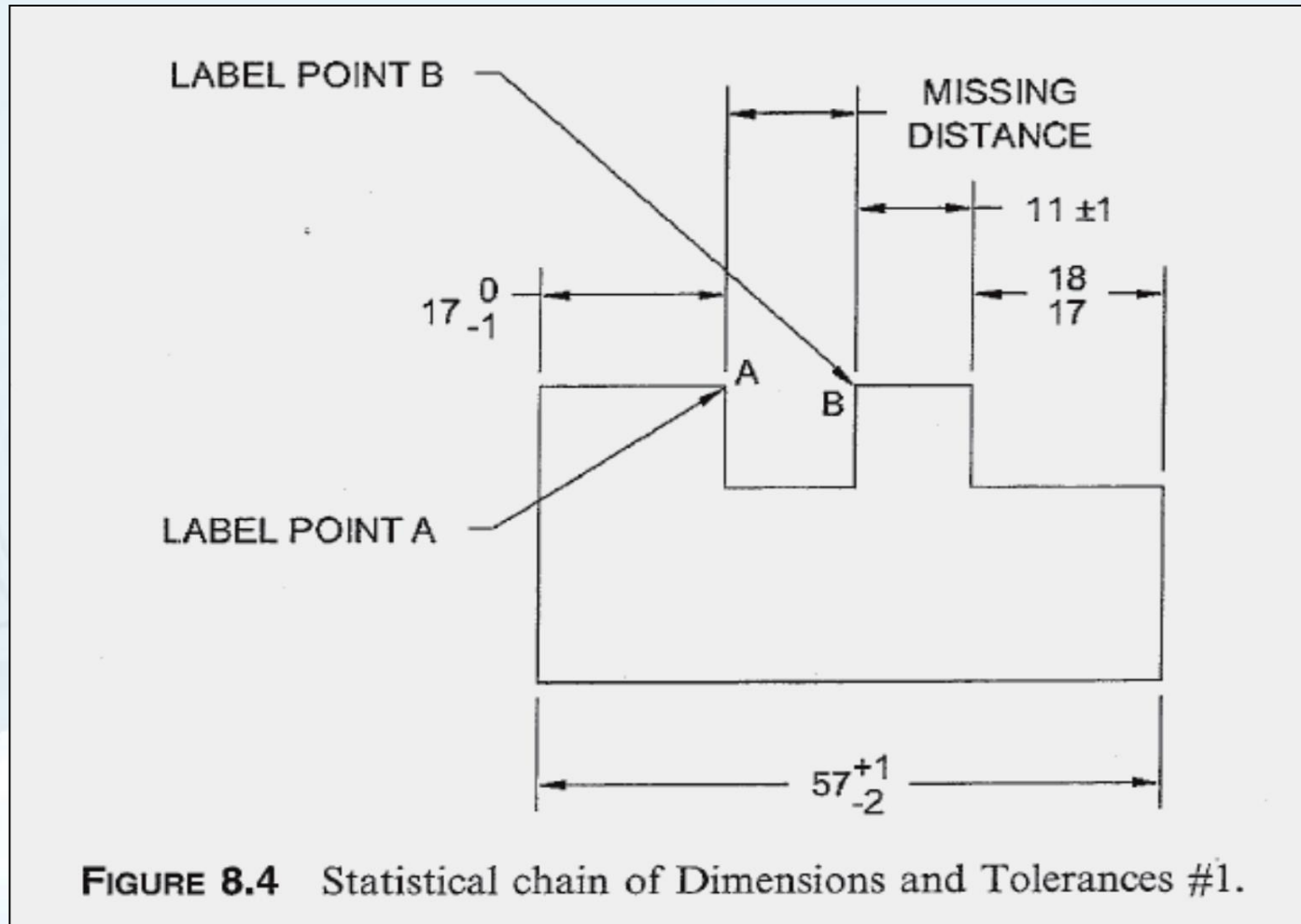

**FIGURE 8.4** Statistical chain of Dimensions and Tolerances #1.



# Statistical Tolerance Analyses Case

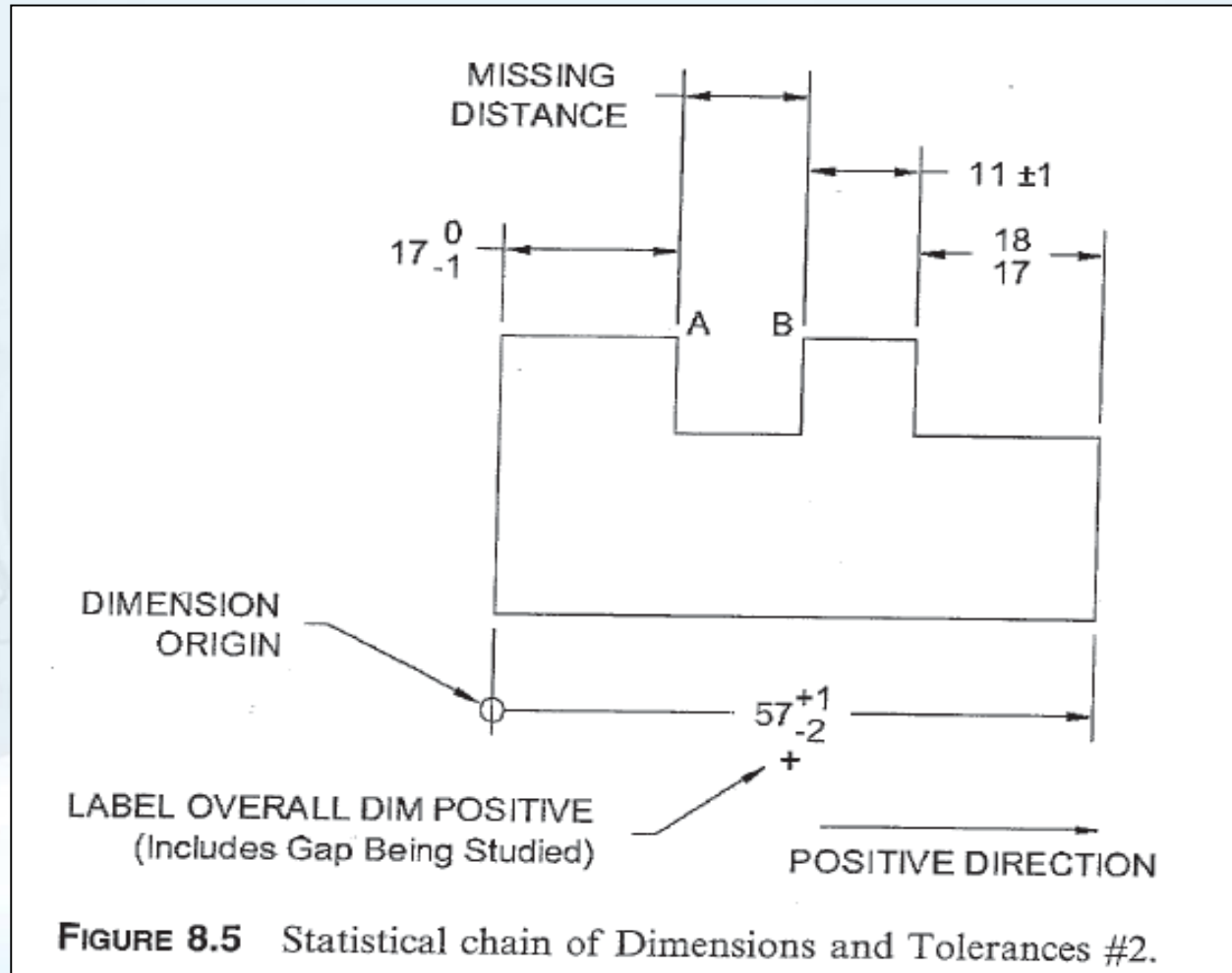

# Statistical Tolerance Analyses Case

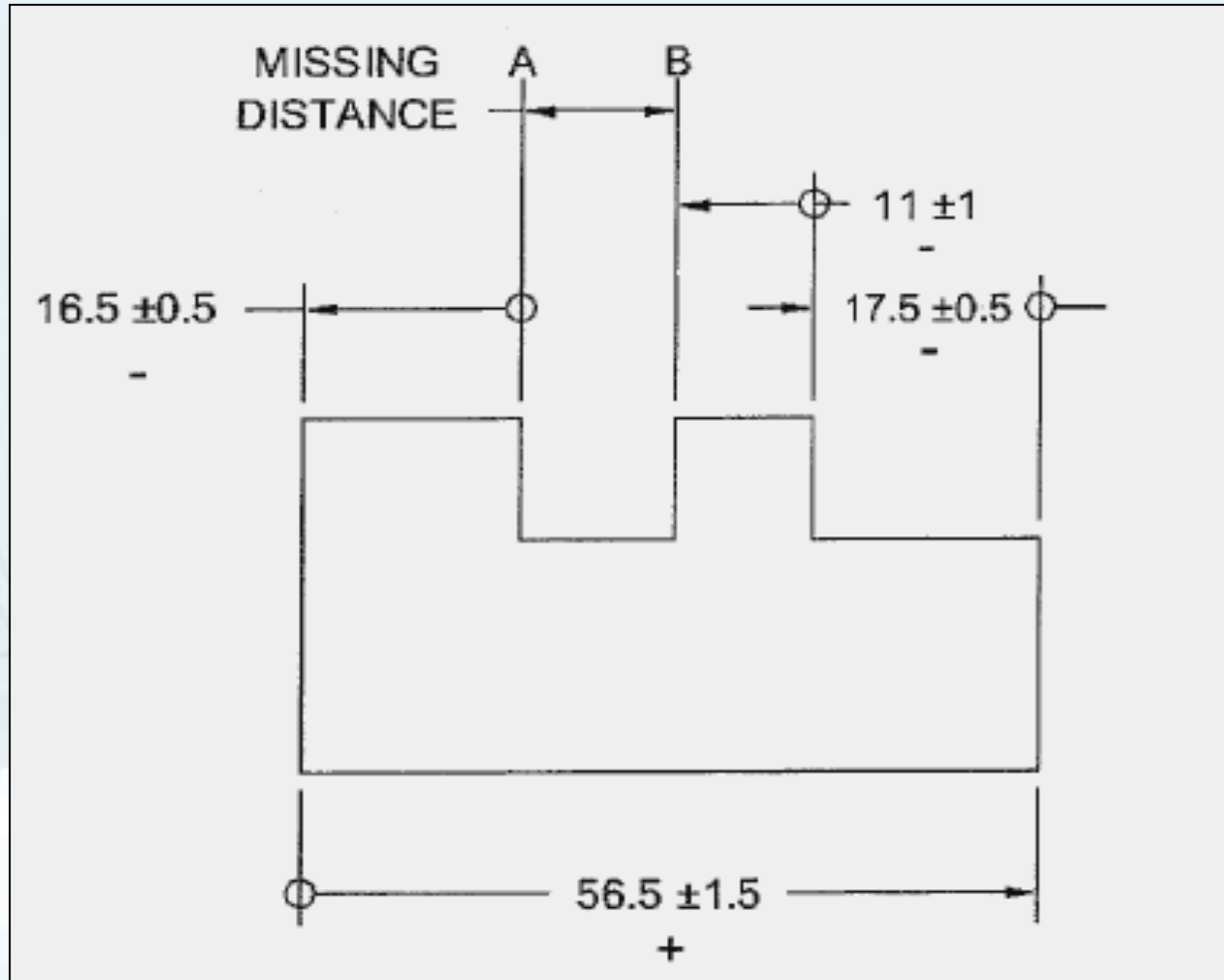

# Statistical Tolerance Analyses Case

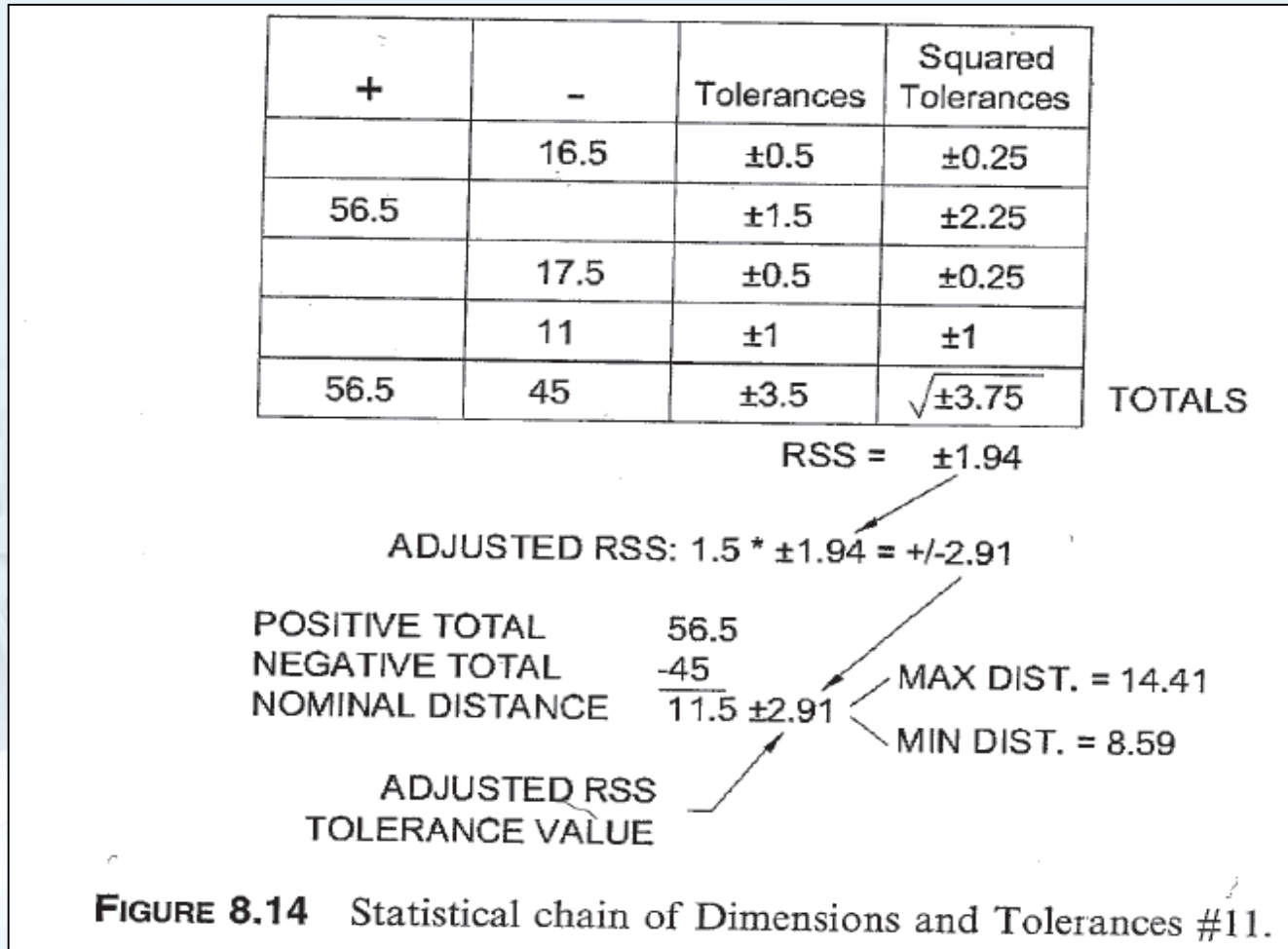

# Statistical Tolerance Analyses Case

Program: Electronics Packaging Program AV-11						<u>Stack Information</u>			
Product: Part Number Rev Description 12345678-001 A Ground Plate Enclosure Assembly: Option 1 w 8 Holes as Datum Feature B						Stack No: AV-11-010a Date: 07/04/02 Revision: A			
Problem: Edges of Ground Plate must not Touch Walls of Enclosure						Direction: Along Plane of Ground Plate (Y Axis)			
Objective: Option 1: Determine if Ground Plate Contacts Enclosure Walls						Author: BR Fischer			

Description of Component / Assy	Part Number	Rev	Item	Description	+ Dims	- Dims	Tol	Percent Contrib	Dim / Tol Source & Calcs
Enclosure	12345678-002	A	1	Profile: Edge Along Pt A			+/- 0.5000	19%	Profile 1, A, Bm
			2	Datum Feature Shift: $(DF_{B@MMC} - DFS_B) / 2$			+/- 0.2900	11%	$= (3.422 - (3.242 - 0.4)) / 2$ (Shift within Minor Dia)
			3	Dim: Edge of Enclosure - Datum B	6.5000		+/- 0.0000	0%	B.5 Basic on Dwg
			4	Position: $DF_B$ M4 Holes			+/- 0.2000	8%	Position dia 0.4 @ MMC A
			5	Bonus Tolerance			+/- 0.0000	0%	NA - Threads
			6	Datum Feature Shift: $(DF_{B@LMC} - DFS_B) / 2$			+/- 0.0000	0%	NA - $DF_A$ not a Feature of Size
			7	Assembly Shift: $(Mounting Holes_{LMC} - F_{LMC}) / 2$			+/- 0.6650	25%	$= ((5 + 0.15) - 3.82) / 2$
Ground Plate	12345678-004	A	8	Position: $DF_B$ Dia 5+/-0.1 Holes			+/- 0.2250	9%	Position dia 0.45 @ MMC A
			9	Bonus Tolerance			+/- 0.1000	4%	$= (0.1 + 0.1) / 2$
			10	Datum Feature Shift: $(DF_{B@LMC} - DFS_B) / 2$			+/- 0.0000	0%	NA - $DF_A$ not a Feature of Size
			11	Dim: Datum B - Edge of Ground Plate		6.0000	+/- 0.0000	0%	B Basic on Dwg
			12	Profile: Edge Along Pt B			+/- 0.5000	19%	Profile 1, A, Bm
			13	Datum Feature Shift: $(DF_{B@LMC} - DFS_B) / 2$			+/- 0.1500	6%	$= ((5 + 0.15) - (5 - 0.15)) / 2$
Dimension Totals					8.5000	6.0000			
Nominal Distance: Pos Dims - Neg Dims =						2.5000			

RESULTS:	Nom	Tol	Min	Max
Arithmetic Stack (Worst Case)	2.5000	+/- 2.6300	-0.1300	5.1300
Statistical Stack (RSS)	2.5000	+/- 1.0721	1.4279	3.5721
Adjusted Statistical: 1.5*RSS	2.5000	+/- 1.6082	0.8918	4.1082

Notes:

- M4 Screw Dimensions: Major Dia: 4 / 3.82 - M4 Tapped Hole Dimensions: Minor Dia: 3.422 / 3.242
- Used min and max screw thread minor dia in Datum Feature Shift Calculations on line 2.
- Used smallest screw major dia in Assembly Shift Calculations on line 7.

Assumptions:

- Assume threads are self centering. Do not include bonus tolerance on line 5.

Suggested Action:

- May want to use two holes as locators instead of all eight. See Stack Opt - 2.

FIGURE 8.15 Sample Tolerance Stackup report form.

# Statistical Tolerance Analyses

## Example #8.1

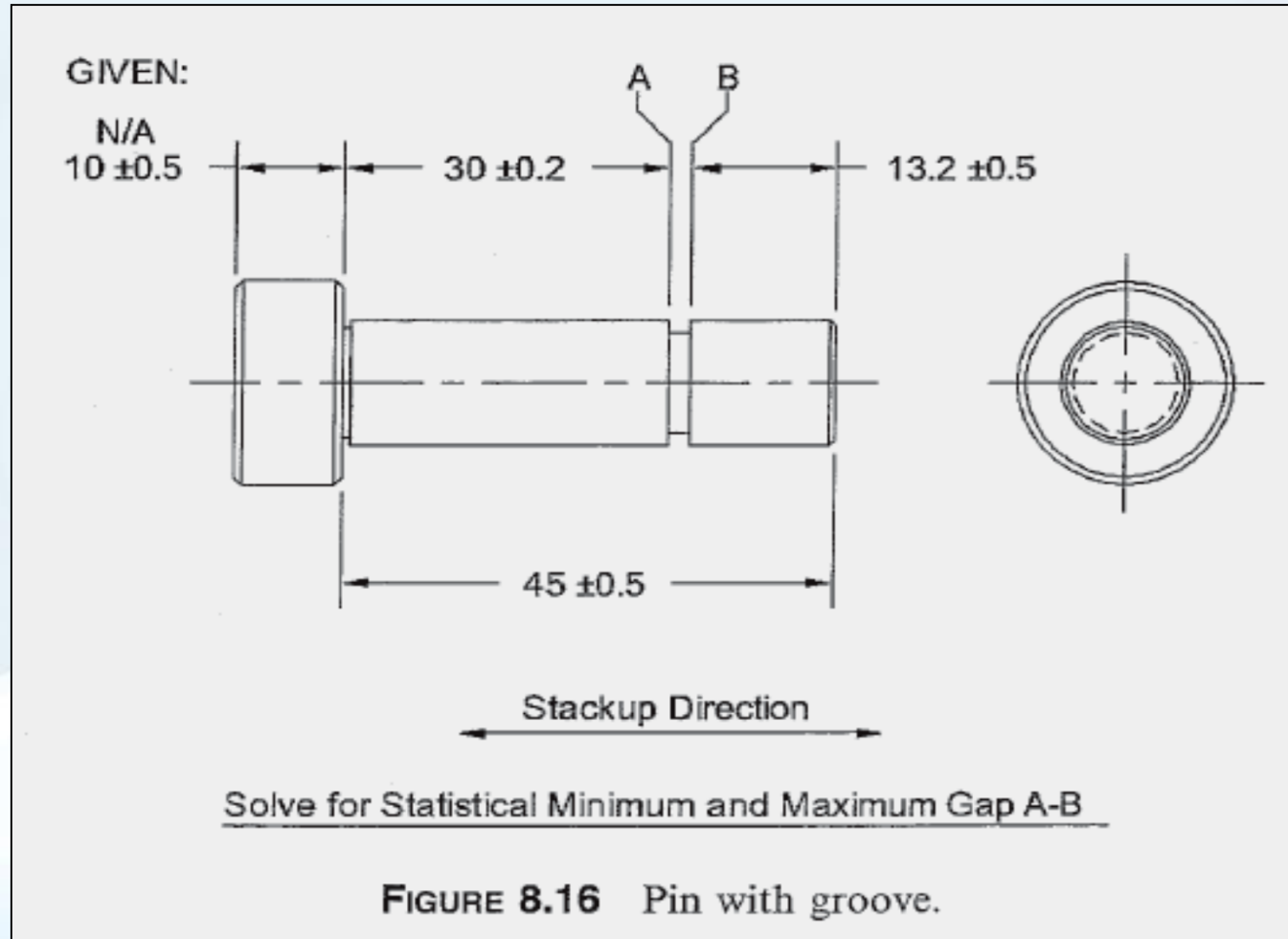
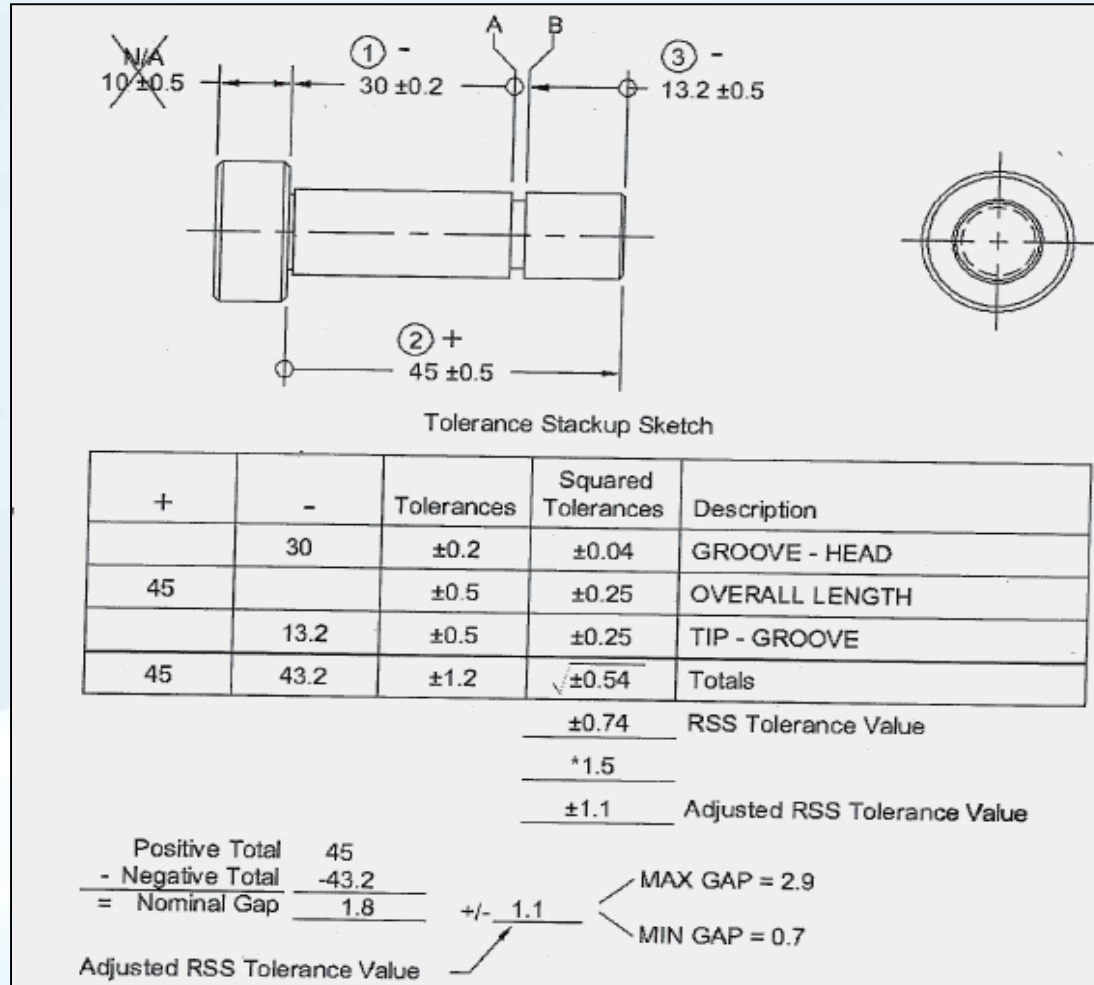

FIGURE 8.16 Pin with groove.

# Statistical Tolerance Analyses

## Example #8.1





# Statistical Tolerance Analyses

## Example #8.2

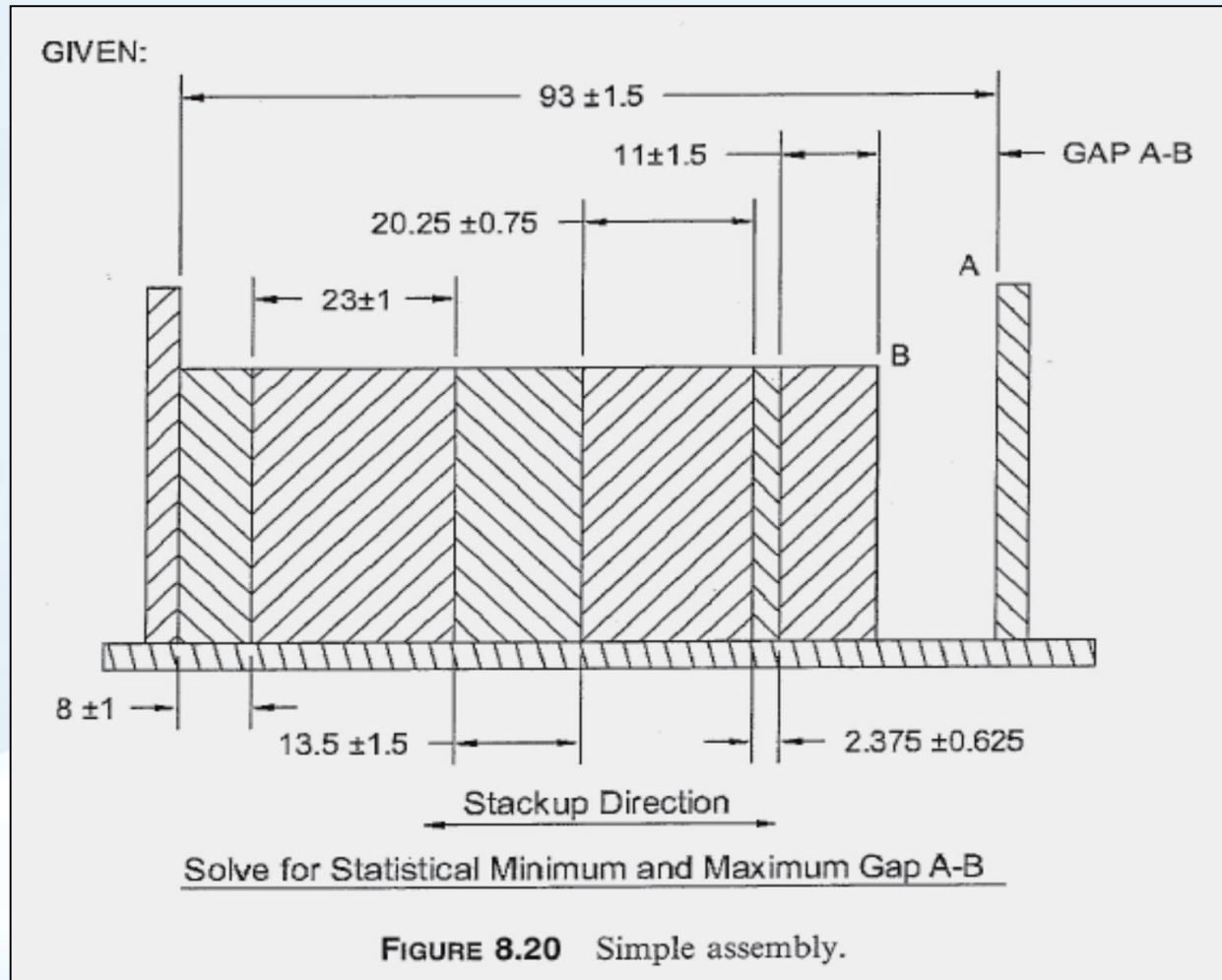

# Statistical Tolerance Analyses

## Example #8.2

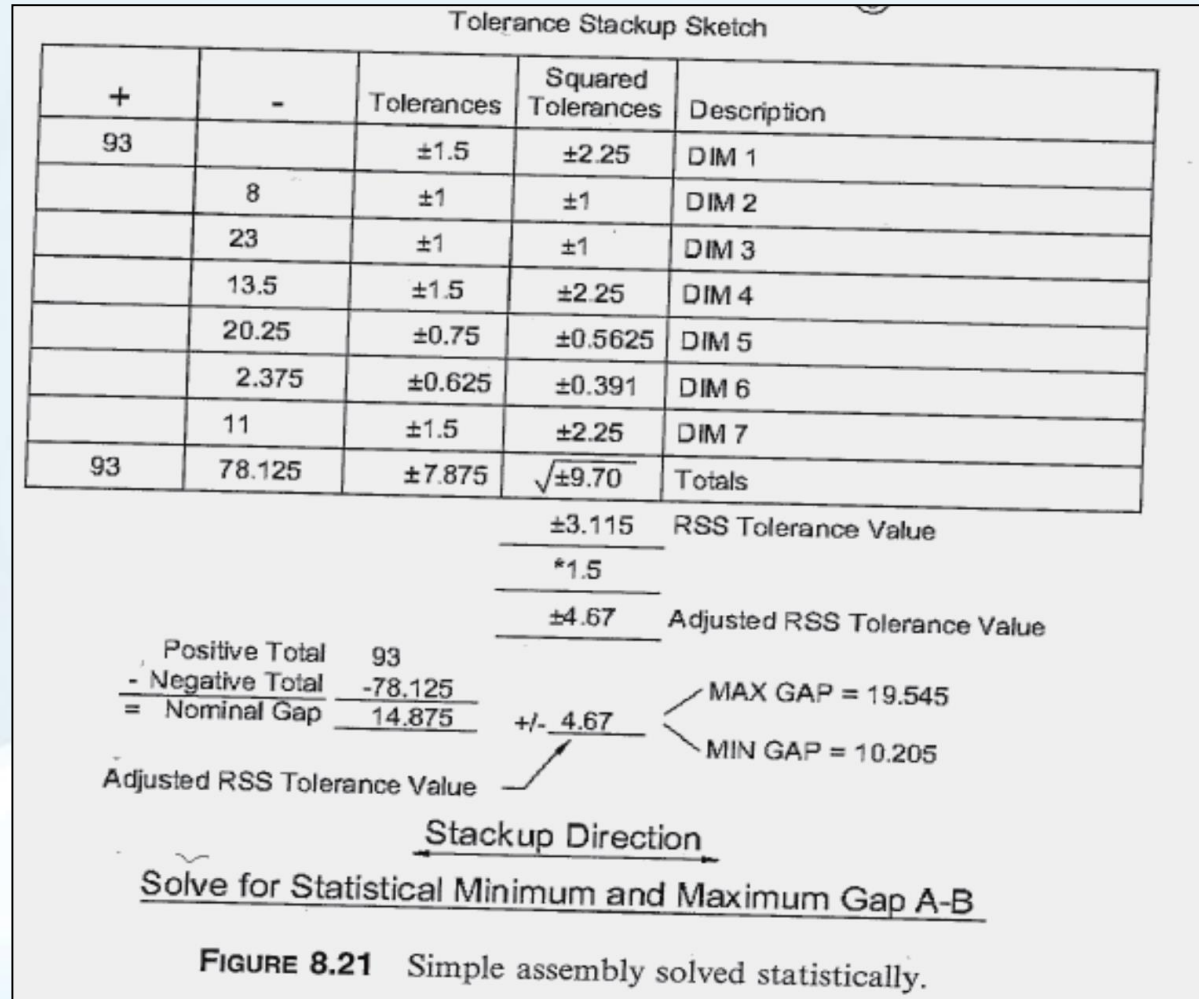

# Statistical Tolerance Analyses

## Example #8.3

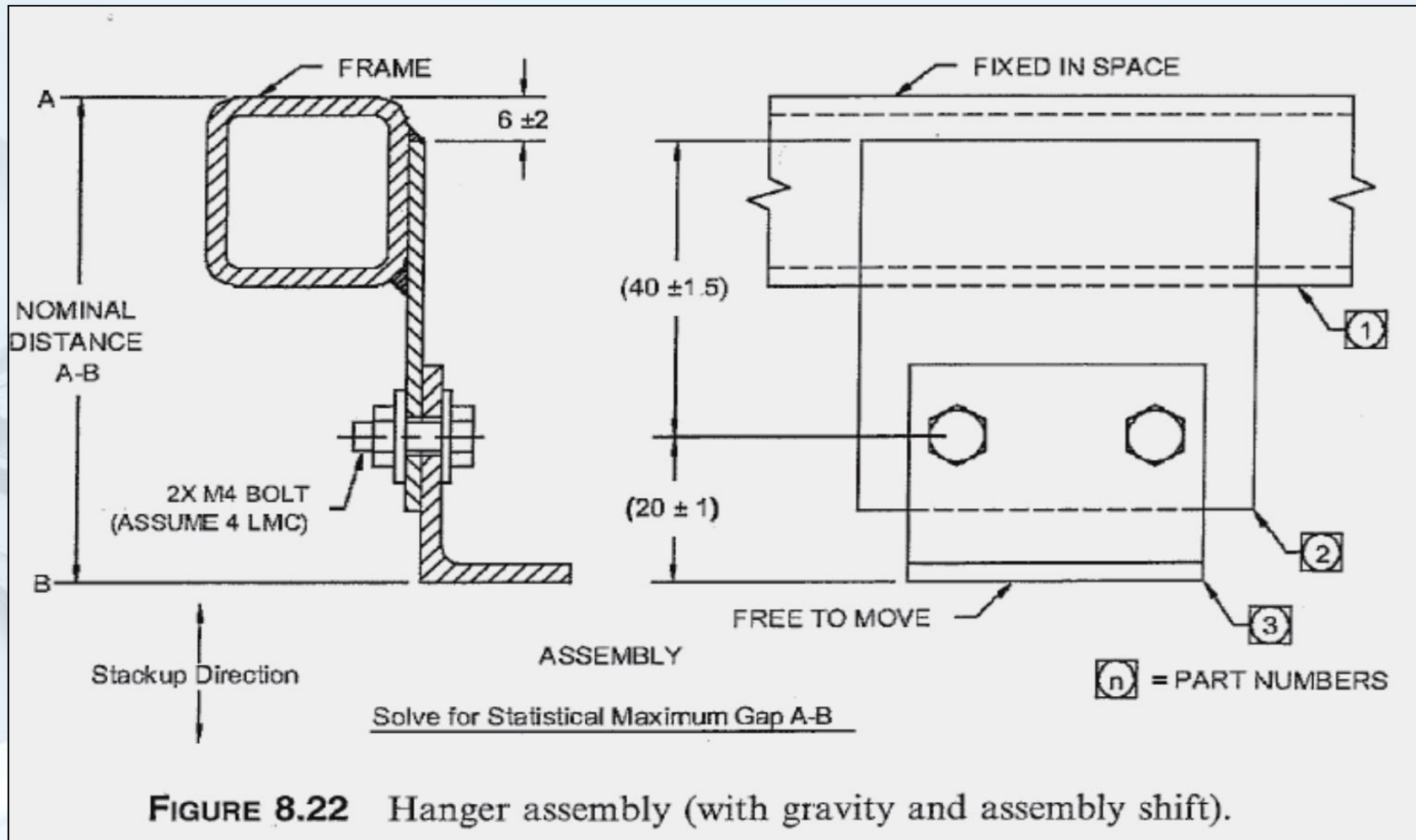

**FIGURE 8.22** Hanger assembly (with gravity and assembly shift).

# Statistical Tolerance Analyses

## Example #8.3

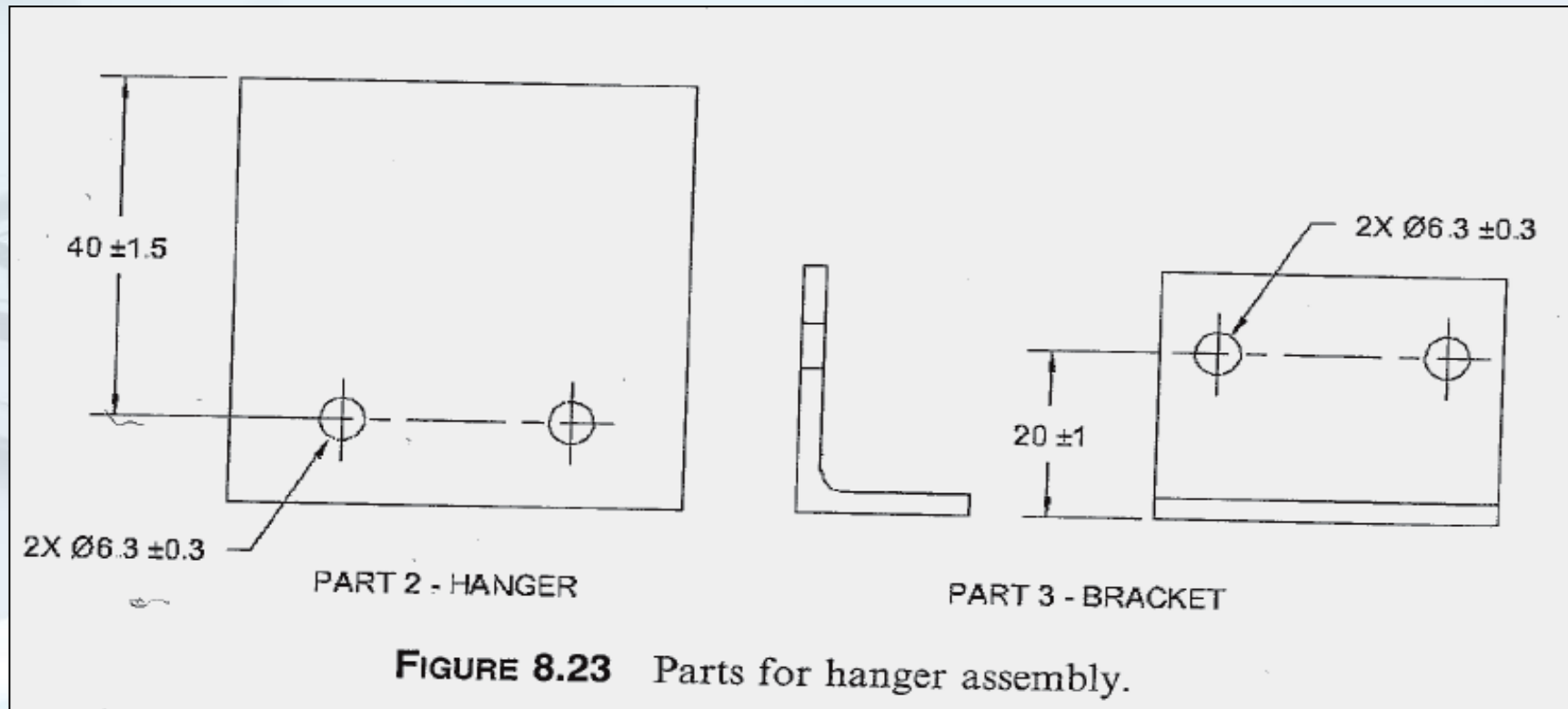

**FIGURE 8.23** Parts for hanger assembly.

# Statistical Tolerance Analyses Example #8.3

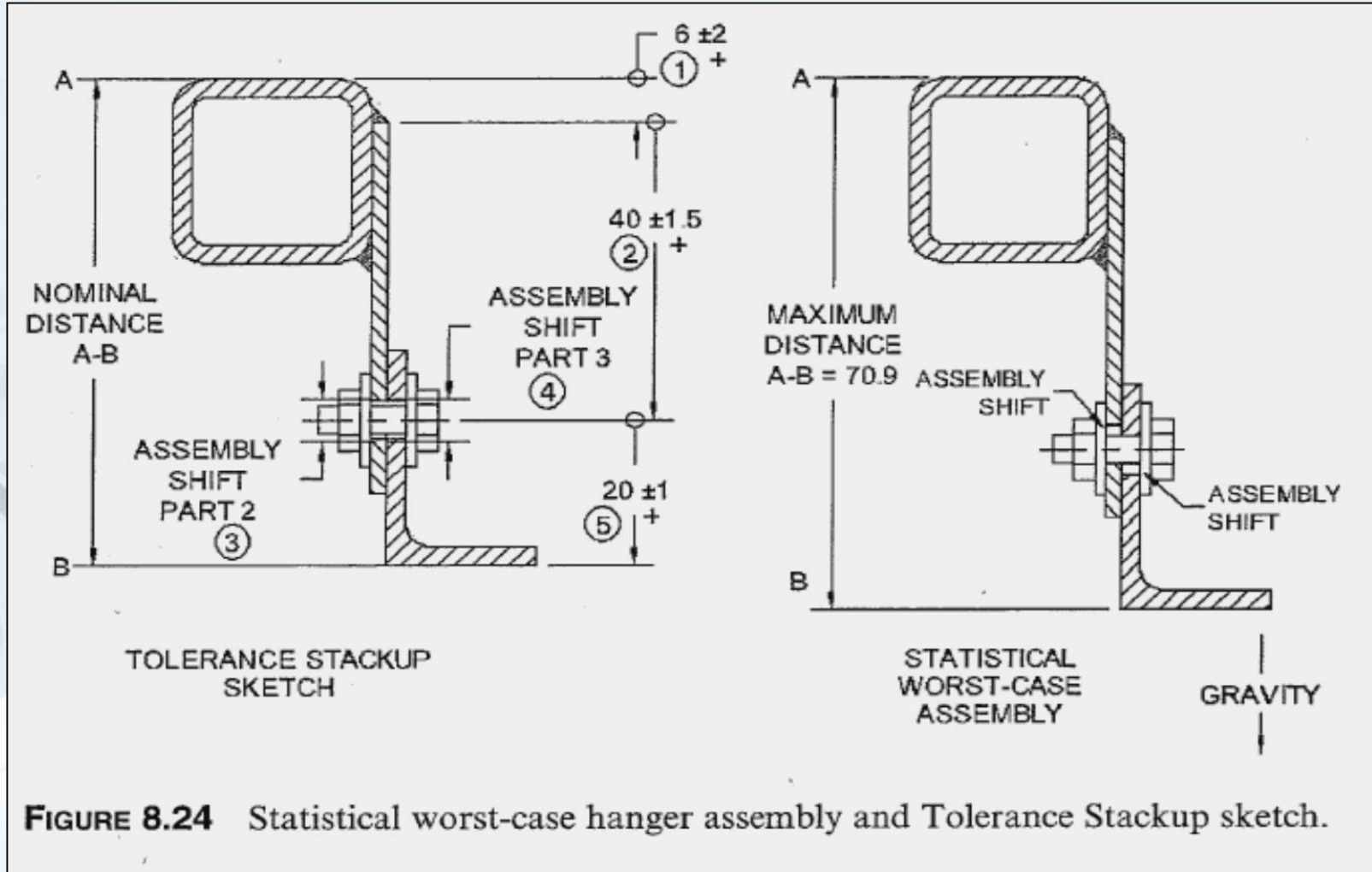

FIGURE 8.24 Statistical worst-case hanger assembly and Tolerance Stackup sketch.



# Statistical Tolerance Analyses Example #8.3

+	-	Tolerances	Squared Tolerances	Description
6		±2	±4	DIM 1: PART 1 - PART 2
40		±1.5	±2.25	DIM 2: PART 2 EDGE - HOLES
		±1.3	±1.69	DIM 3: ASSY SHIFT PART 2: 6.3(H) + 0.3(ST) - 4(F) = 2.6 / 2 = ±1.3
		±1.3	±1.69	DIM 4: ASSY SHIFT PART 3: 6.3(H) + 0.3(ST) - 4(F) = 2.6 / 2 = ±1.3
20		±1	±1	DIM 5: PART 3 HOLES - FLANGE
66	0	±7.1	$\sqrt{\pm 10.63}$	Totals

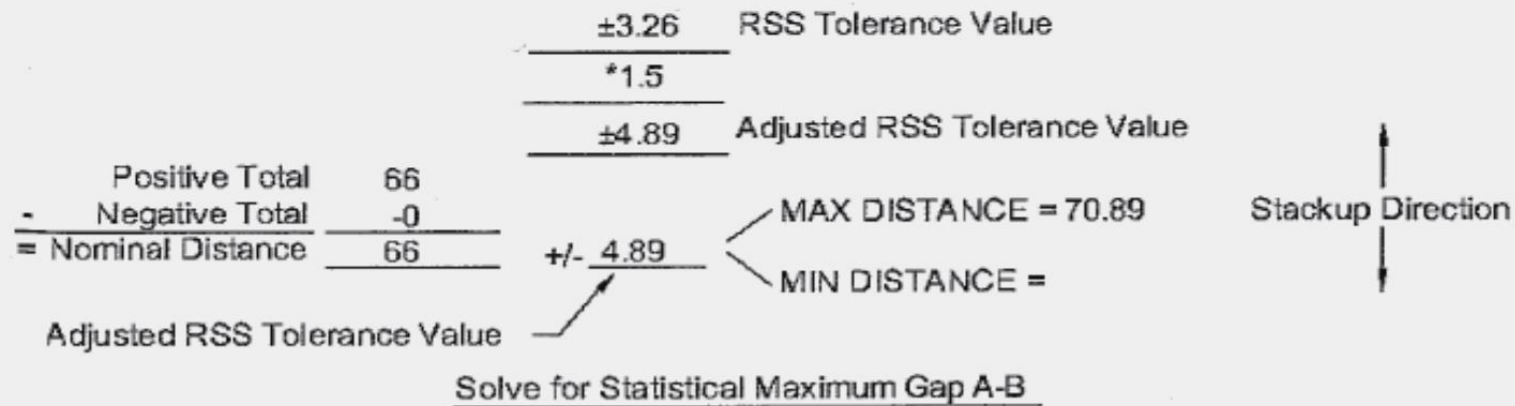
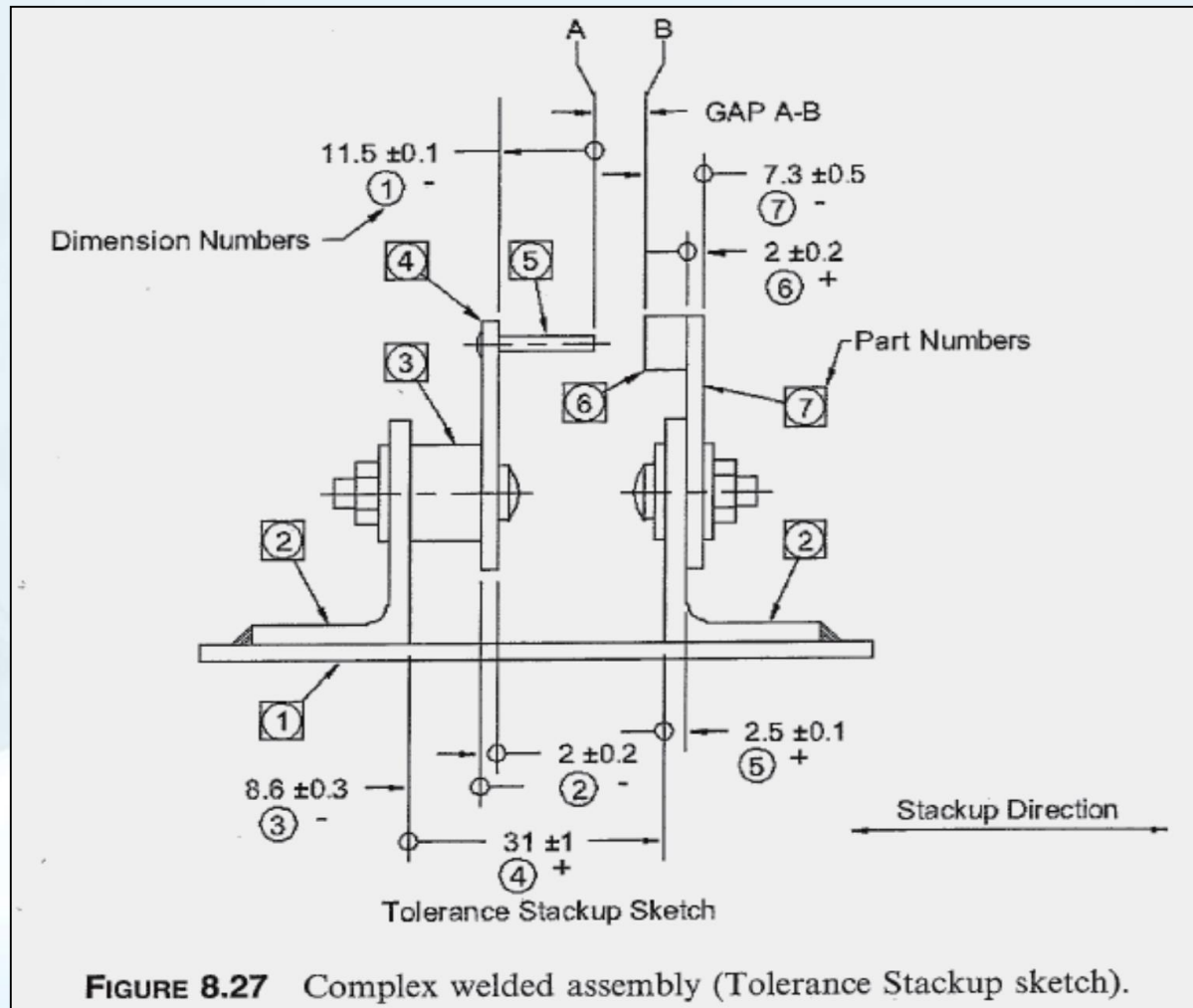

FIGURE 8.25 Tolerance Stackup report solved statistically.





# Statistical Tolerance Analyses Example #8.4



## Statistical Tolerance Analyses Example #8.4

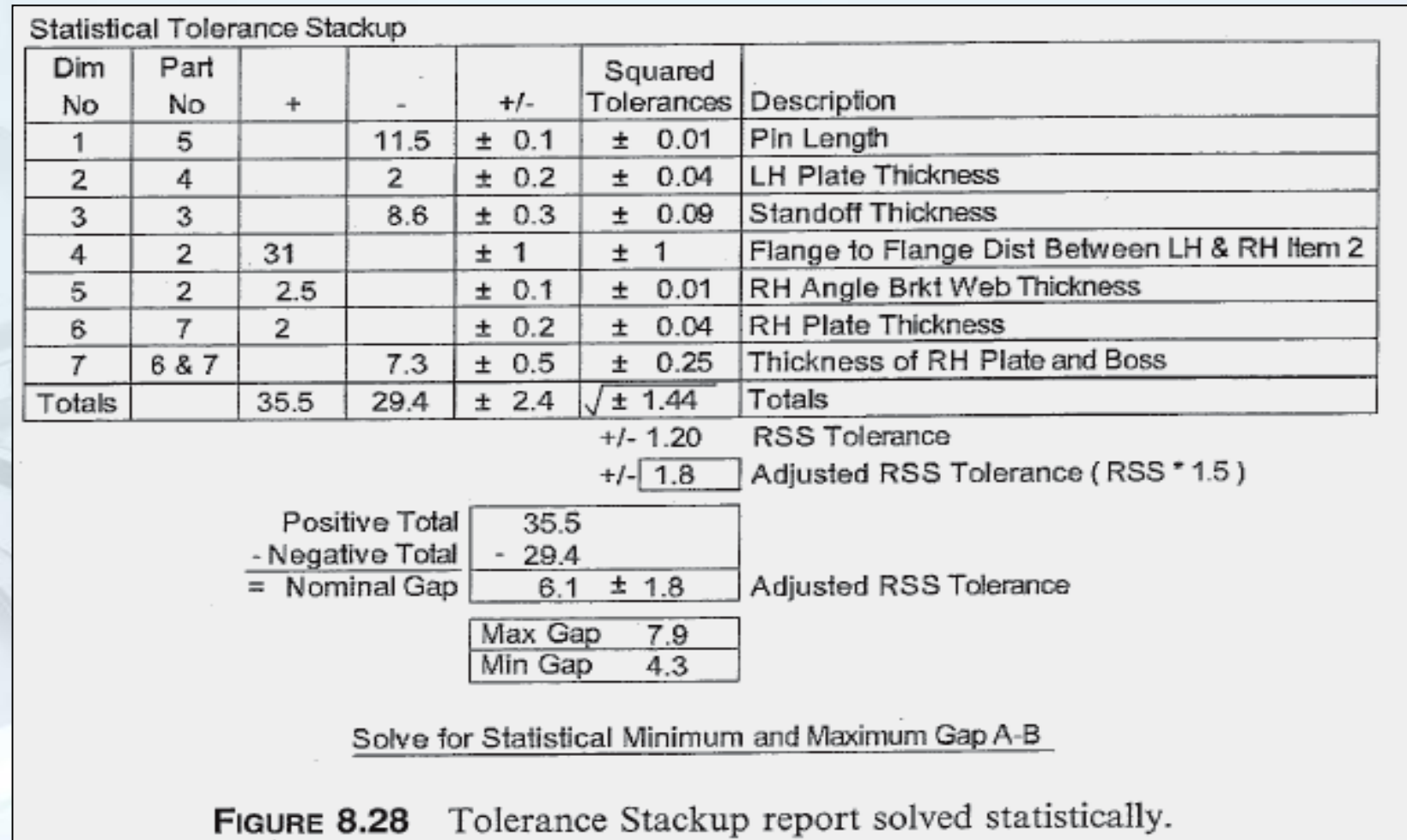

# Statistical Tolerance Analyses Example #8.5

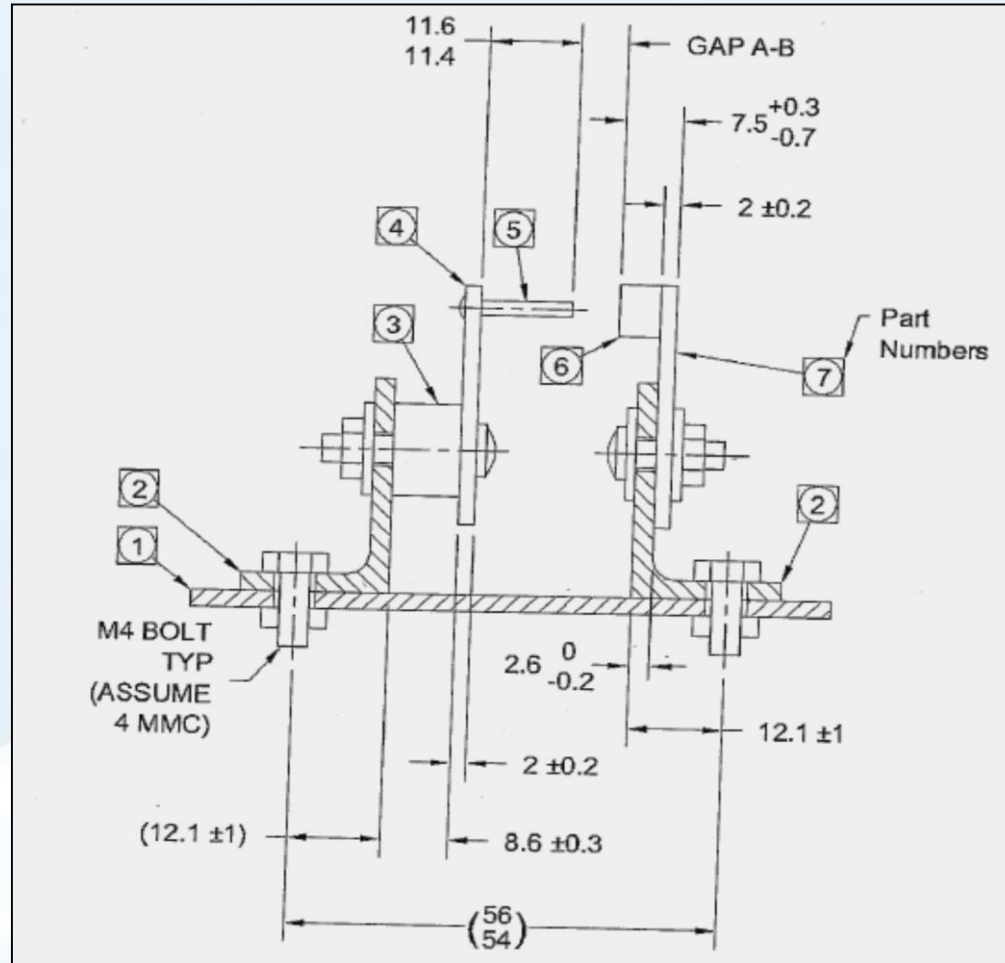

**Solve for Minimum and Maximum Gap A-B**

# Statistical Tolerance Analyses Example #8.5

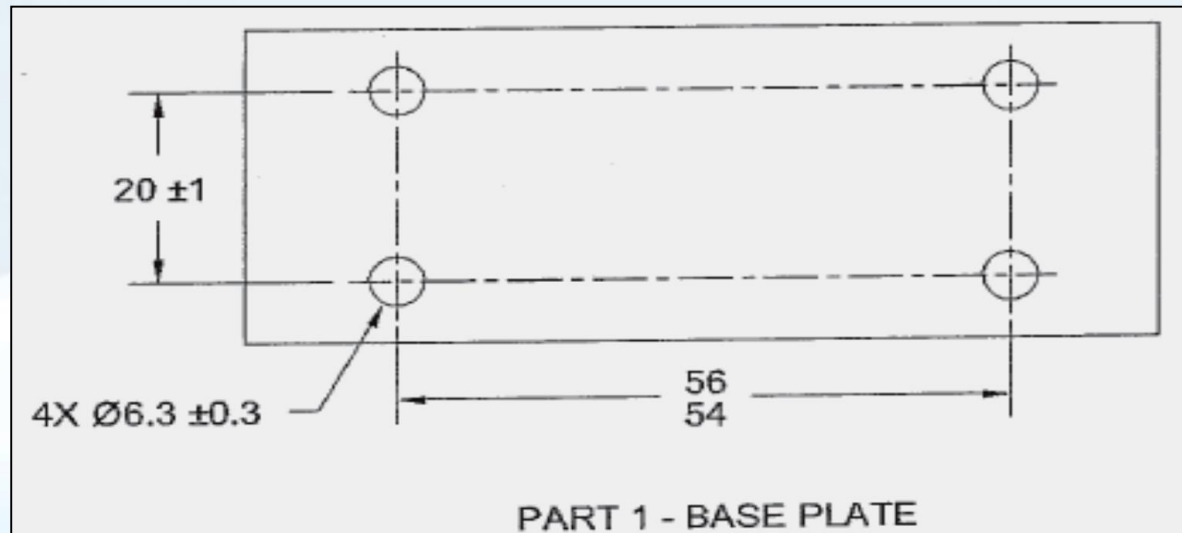
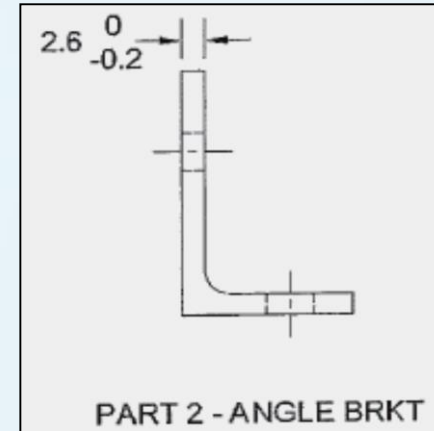
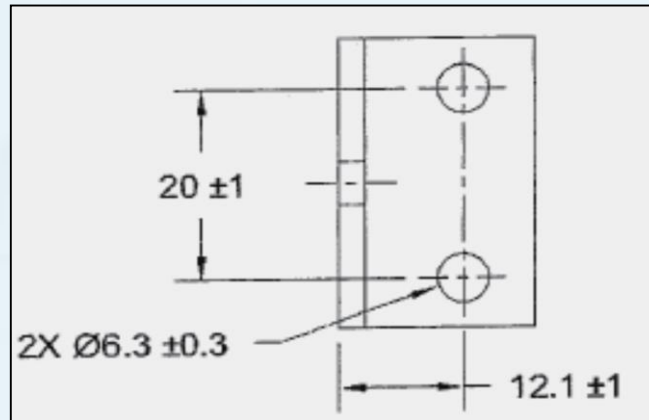

# Chapter #9

QUALITY

## Geometric Dimensioning and Tolerancing





### GD&T Advantage

- GD&T creates coordinate systems based on datum reference frames all features on a part are unambiguously related to these coordinate systems
- Tolerance Stack ups done on parts and assemblies that have been properly dimensioned and toleranced with GD&T are easier and more straightforward than with parts defined by  $\pm$  dimensions and tolerances.
- Tolerance Stack ups performed on parts with GD&T require far fewer assumptions regarding how to interpret the tolerance specifications.

### Converting GD&T Into Equal Bilateral Tolerances

- parts and assemblies dimensioned with GD&T must also be converted to equal bilateral  $\pm$  tolerances before a Tolerance Analysis can be completed.
- Plus/minus dimensions and tolerances are still used with drawings based on GD&T, but their use should be limited to defining features of size and the depth or length of features such as holes and pins.
- For many reasons,  $\pm$  dimensions and tolerances should not be used to locate features.

# Profile Tolerances

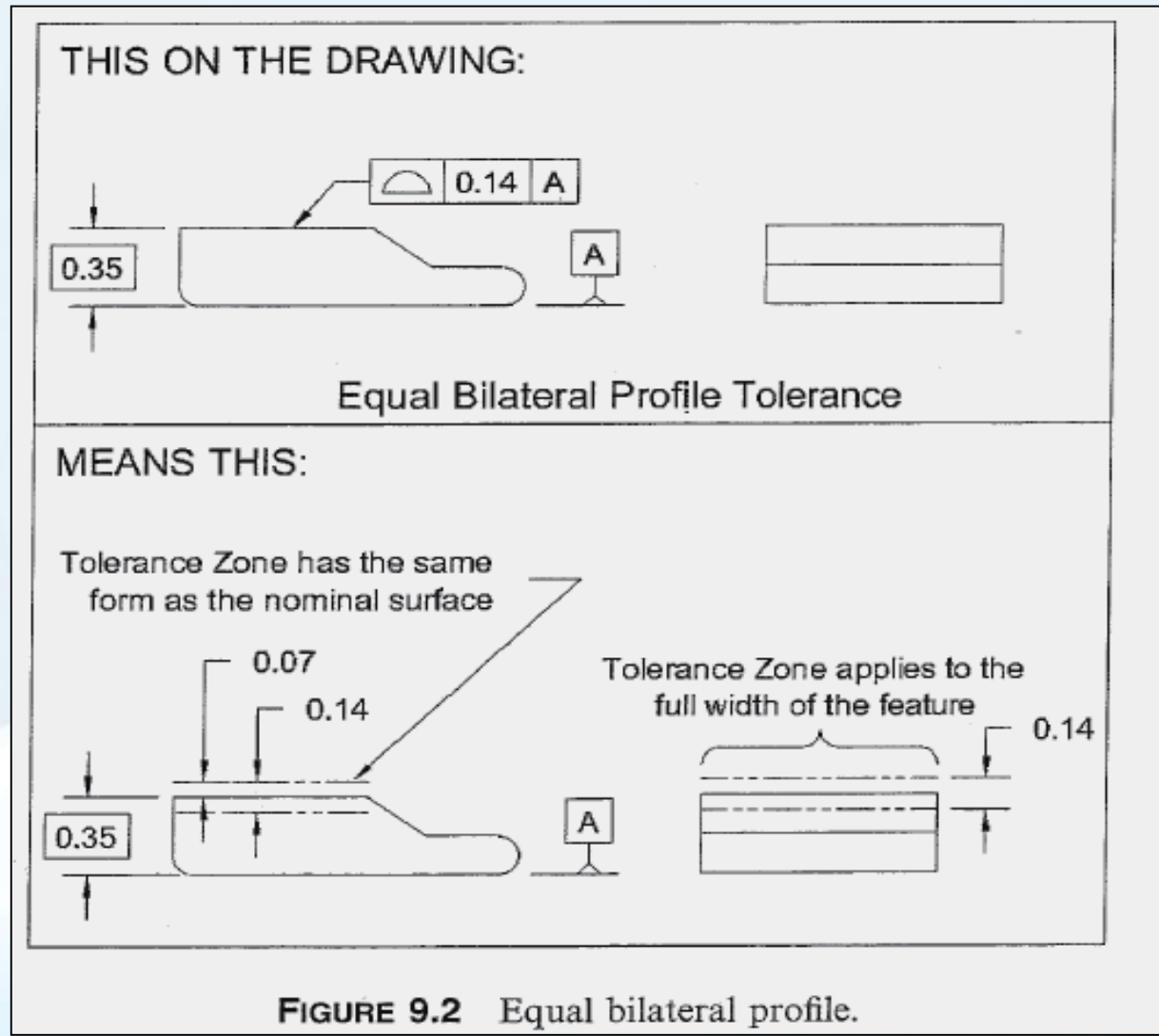

# Profile Tolerances

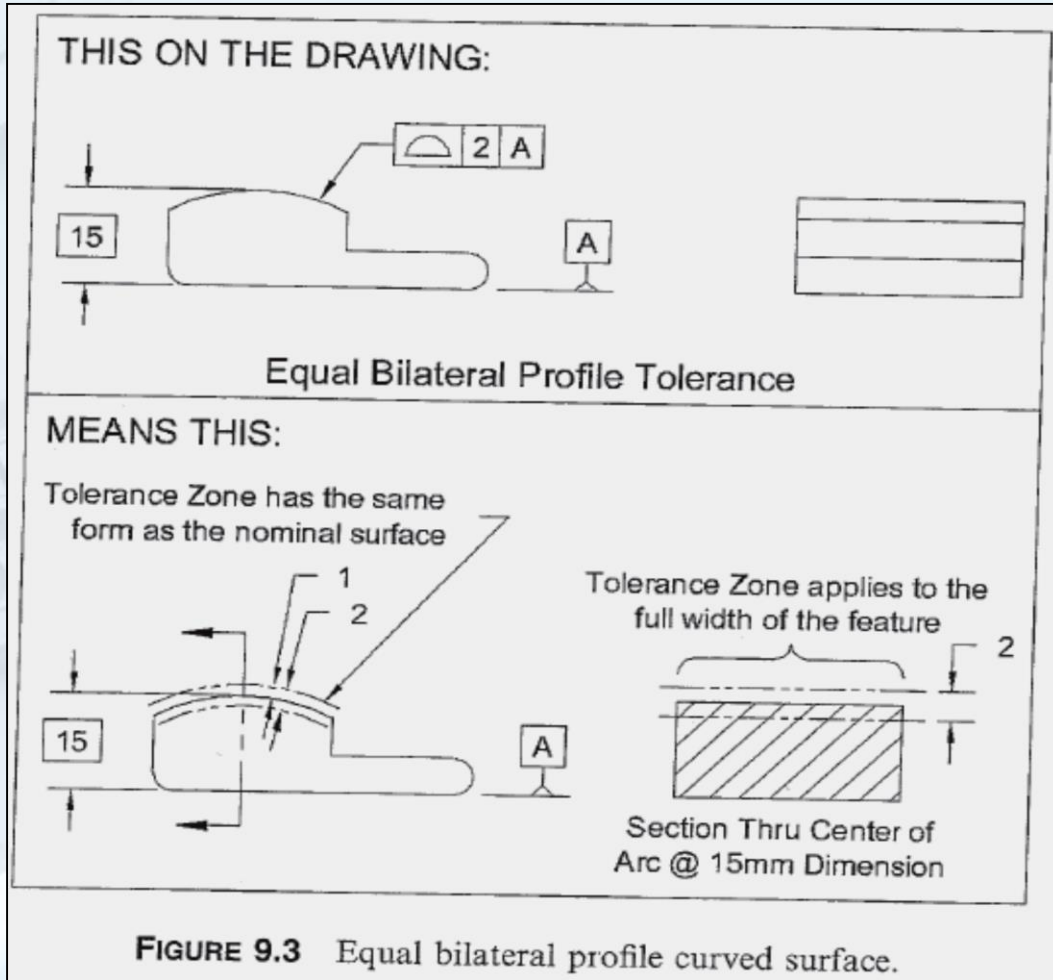

$$15 \pm 1$$

## Profile Tolerances

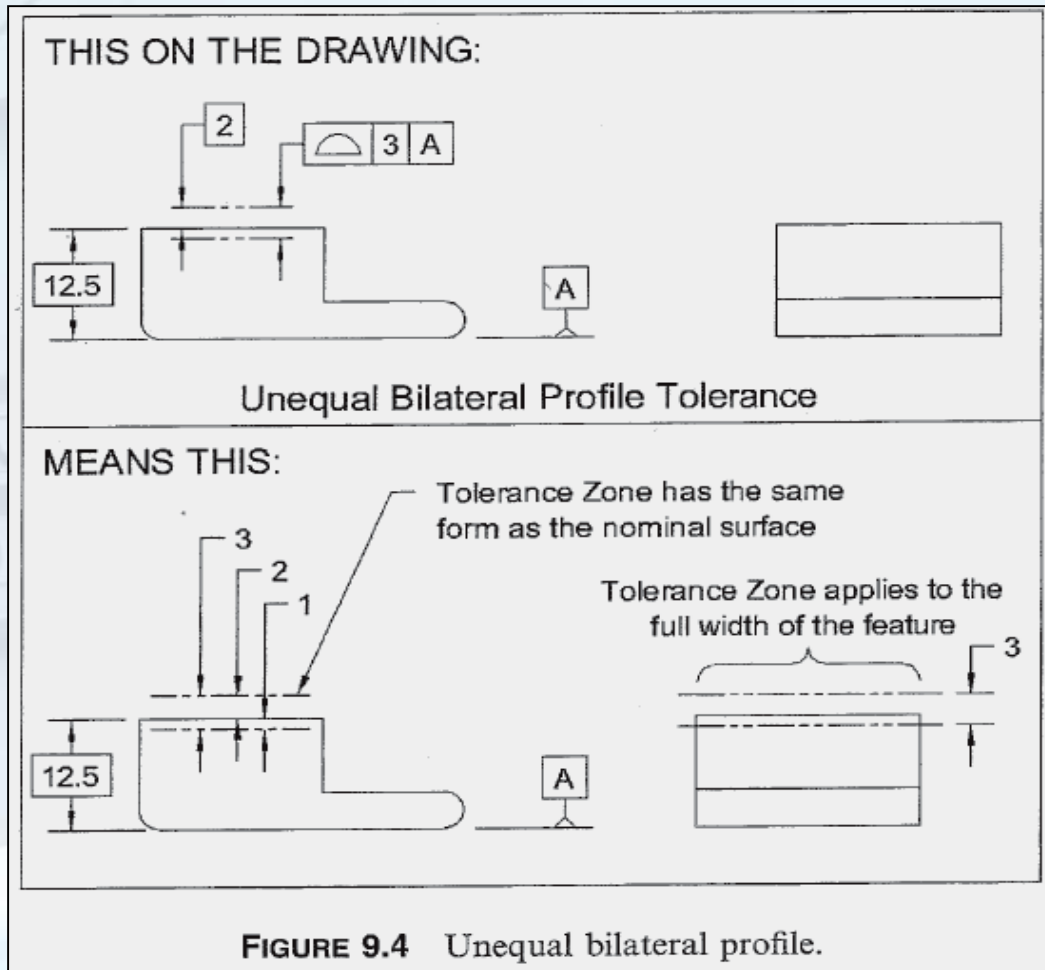

$$\text{Upper limit} = 12.5 + 2 = 14.5$$
$$\text{Lower limit} = 12.5 - 1 = 11.5$$

$$3 = \pm 1.5$$

$$11.5 + 1.5 = 13$$

$$13 \pm 1.5$$

## Profile Tolerances

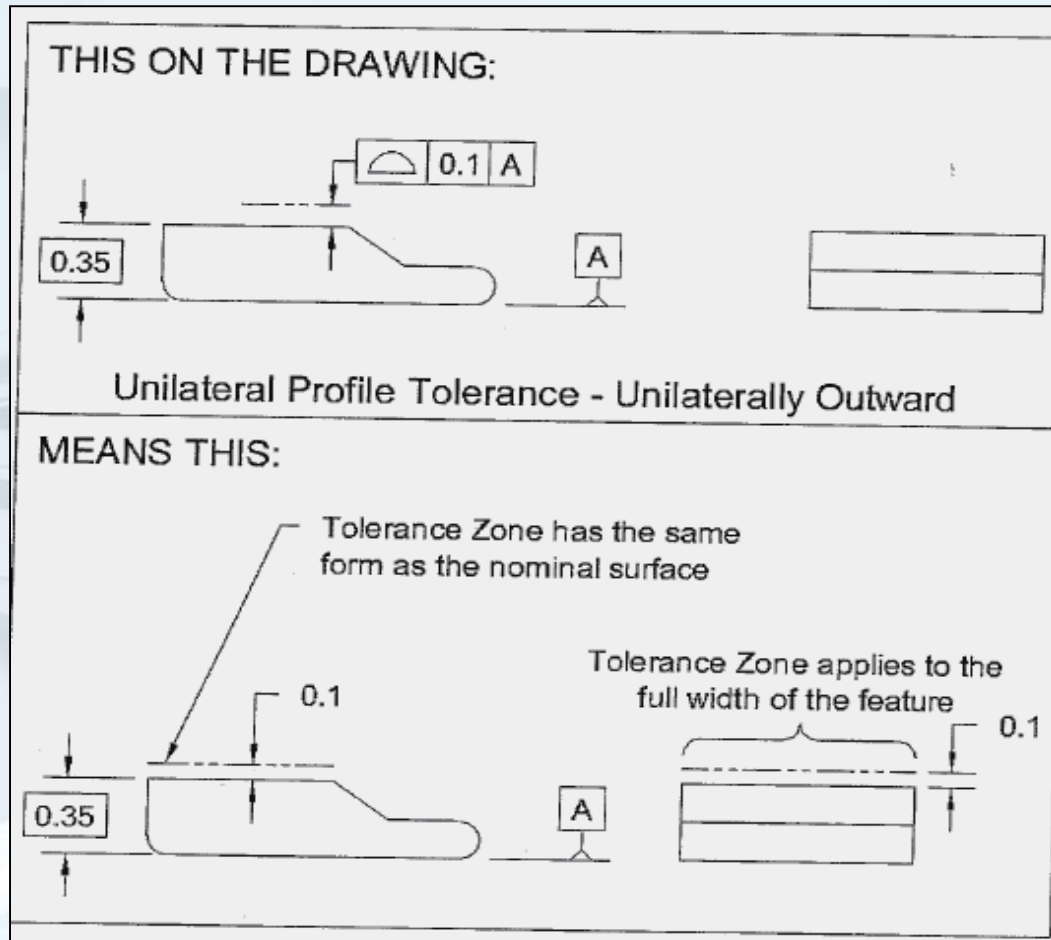

$$\text{Upper limit} = 0.35 + 0.1 = 0.45$$

$$\text{Lower limit} = 0.35 - 0 = 0.35$$

$$0.1 = \pm 0.05$$

$$0.35 + 0.05 = 0.4$$

$$0.4 \pm 0.05$$



### Converting GD&T Into Equal Bilateral Tolerances

- **Composite profile tolerances**

The profile tolerance specified in the uppermost segment of the feature control frame represents the total allowable variation in location of the feature to a datum reference frame.

Typically the tolerance defined in the uppermost segment is used, in Tolerance Stack ups.

# Composite Profile Tolerances

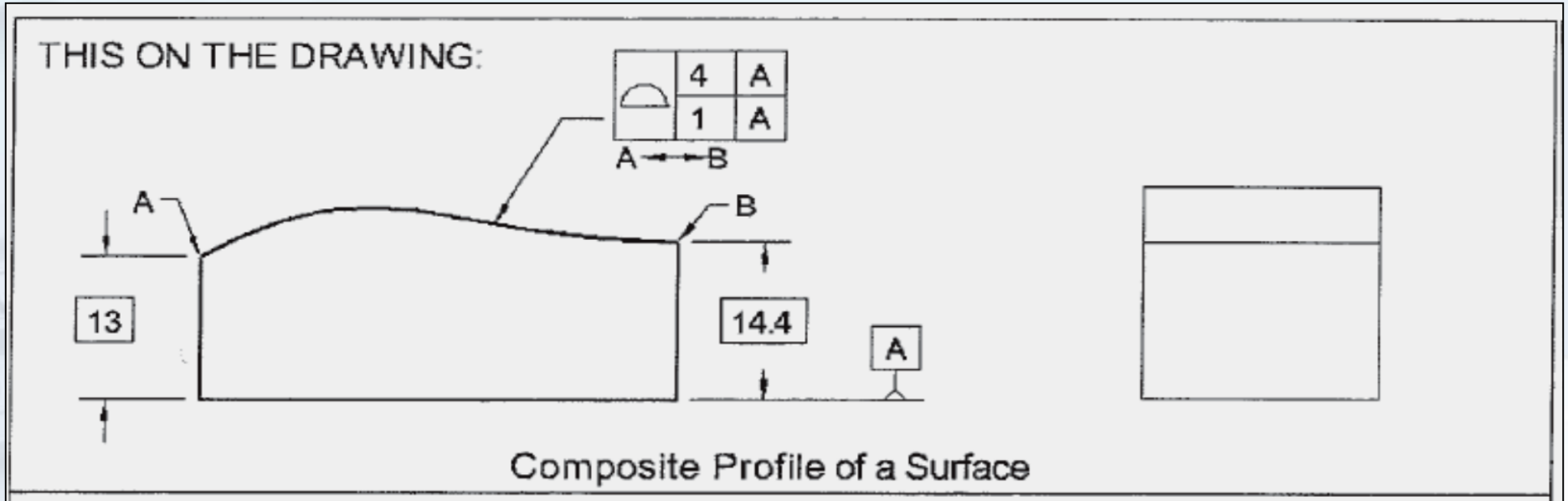

# Chapter #9 Geometric Dimensioning and Tolerancing

## Composite Profile Tolerances Example #9.1

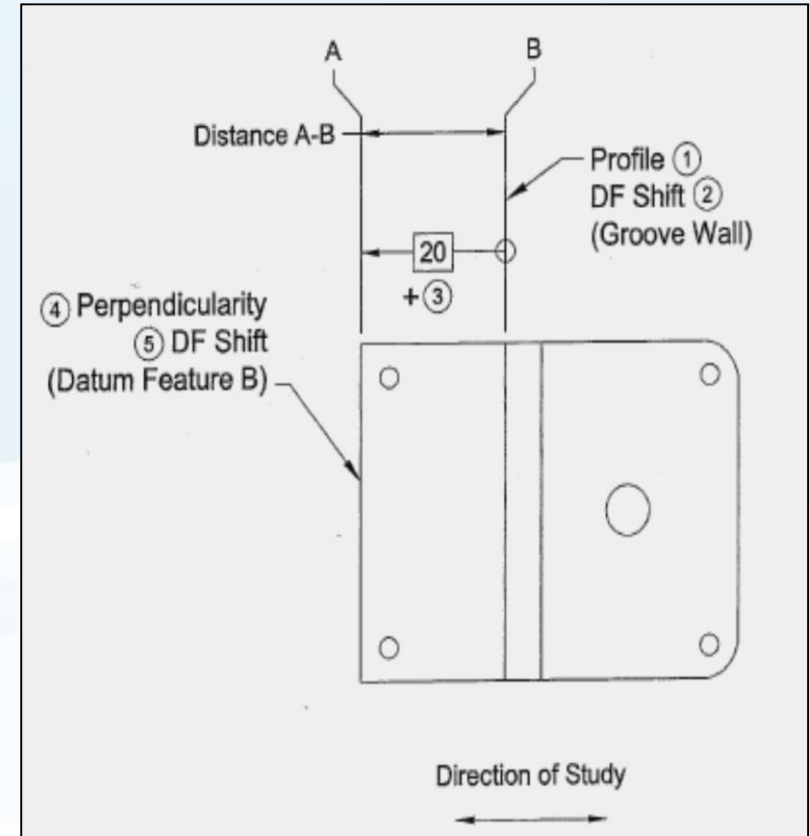
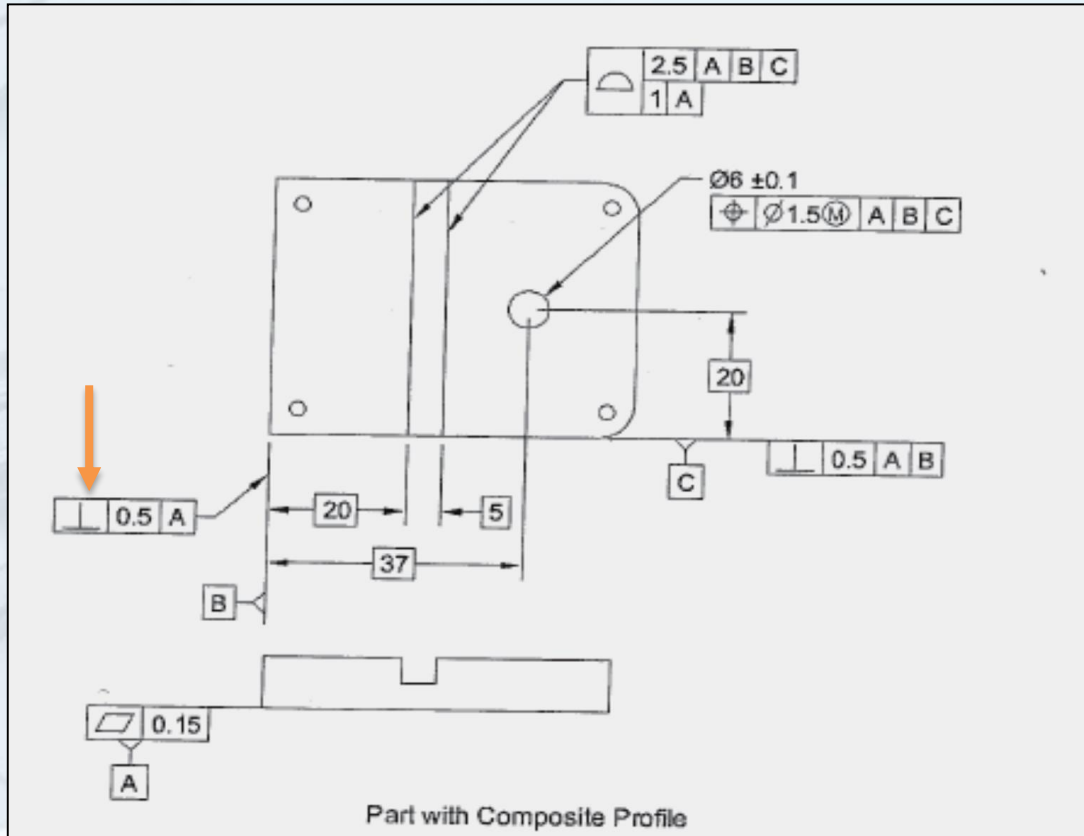

# Chapter #9 Geometric Dimensioning and Tolerancing

## Composite Profile Tolerances Example #9.1

Release 1.2a

**Tolerance Stack**

Program: Tolerance Analysis and Stackup Manual

Product: Part Number Rev Description

- A Part with Groove

Problem: It is important to Know the Minimum Distance Between the Groove Wall and the Left Edge of the Part

Objective: Determine the Minimum Distance Between the Groove Wall and the Left Edge of the Part

Stack Information:  
Stack No: Figure 9-9  
Date: 07/04/02  
Revision: A  
Direction: Horizontal  
Author: BR Fischer

Description of Component / Assy	Part Number	Rev	Item	Description	+ Dims	- Dims	Tol	Percent Contrib	Dim / Tol Source & Calcs
Part with Groove	123-002	A	1	Profile: Edge Along Pt A			+/- 1.2500	83%	Profile 2.5, A, B, C (Upper Segment)
			2	Datum Feature Shift			+/- 0.0000	0%	N/A
			3	Dim: Groove Wall - Datum B	20.0000		+/- 0.0000	0%	20 Basic on Dwg
			4	Perpendicularity: (Datum Feature B)		0.2500	+/- 0.2500	17%	Perpendicularity 0.5, A on Dwg - See Notes
			5	Datum Feature Shift:			+/- 0.0000	0%	N/A
Dimension Totals					20.0000	0.2500			
Nominal Distance: Pos Dims - Neg Dims =					19.7500				

**RESULTS:**

	Nom	Tol	Min	Max
Arithmetic Stack (Worst Case)	19.7500	+/- 1.5000	18.2500	21.2500
Statistical Stack (RSS)	19.7500	+/- 1.2748	18.4752	21.0248
Adjusted Statistical: 1.5*RSS	19.7500	+/- 1.9121	17.8379	21.6621

**Notes:** - The Upper Segment Profile Tolerance is used in this Tolerance Stackup.  
- it must be understood that the Perpendicularity tolerance applied to Datum Feature B allows portions of the Datum Feature to tilt and / or have form error relative to Datum B, which is perfectly perpendicular to Datum A. Therefore the Perpendicularity tolerance should be included in the Tolerance Stackup. The Perpendicularity tolerance only allows the distance between Datum Feature B and the Groove to decrease, so it must be accompanied by a negative Mean Shift. The Perpendicularity tolerance is added as an equal-bilateral tolerance of +/-0.25, with a Mean Shift of 0.25, which is half the Perpendicularity tolerance value. The Mean Shift is indicated by placing the 0.25 value in the "- Dims" column on the same line as the Perpendicularity tolerance. See Chapter 20 for more information.

**Assumptions:**

**Suggested Action:**

## Chapter #9 Geometric Dimensioning and Tolerancing

### Composite Profile Tolerances Example #9.2

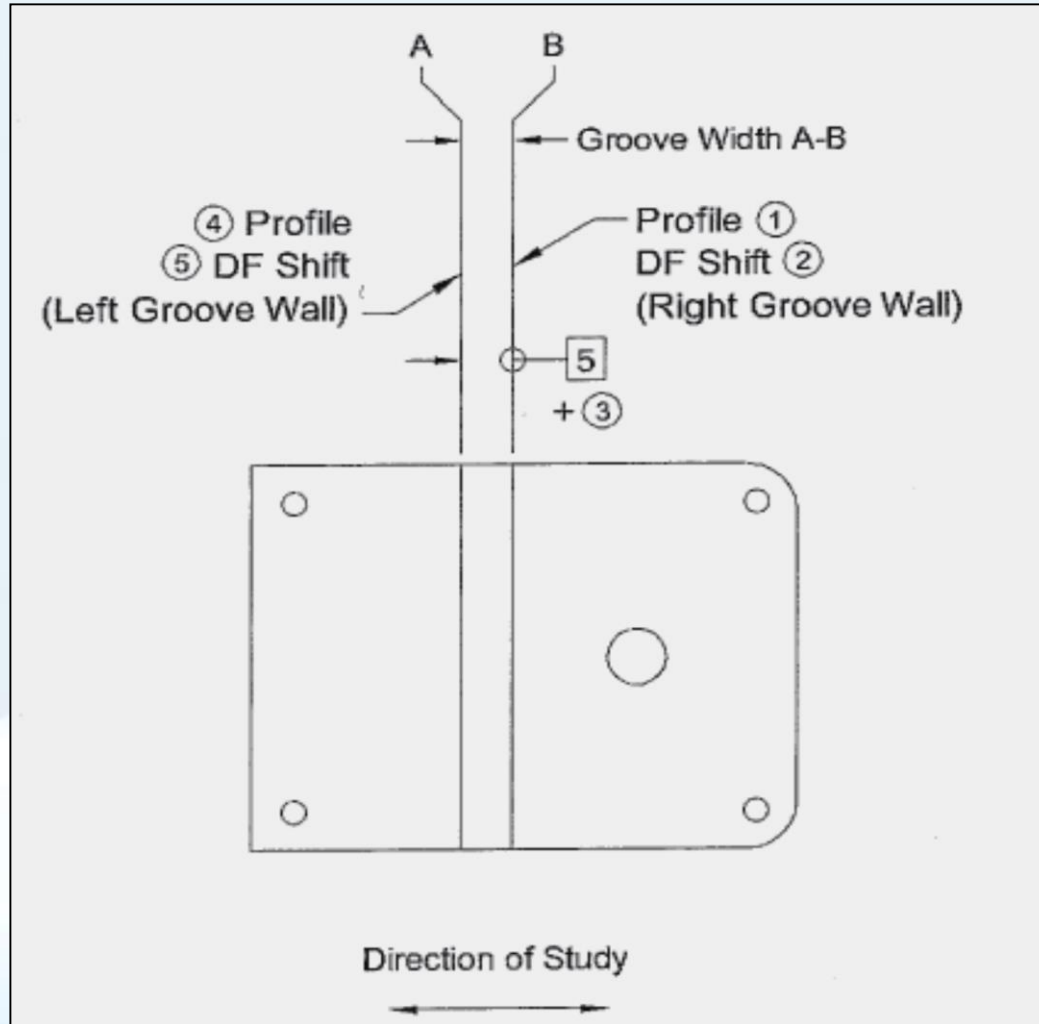

# Chapter #9 Geometric Dimensioning and Tolerancing

## Composite Profile Tolerances Example #9.2

Tolerance Stack										
Program: Tolerance Analysis and Stackup Manual							<u>Stack Information:</u>			
Product: Part Number Rev Description							Stack No: Figure 9-11			
- A Part with Groove							Date: 07/04/02			
Problem: It is Important to Know the Minimum and Maximum Groove Width							Revision: A			
Objective: Determine the Minimum and Maximum Groove Width							Direction: Horizontal			
							Author: BR Fischer			
Description of Component / Assy	Part Number	Rev	Item	Description	+ Dims	- Dims	Tol	Percent Contrib	Dim / Tol Source & Calcs	
Part with Groove	123-002	A	1	Profile: Edge Along Pt A			+/- 0.5000	50%	Profile 1, A (Lower Segment)	
			2	Datum Feature Shift			+/- 0.0000	0%	N/A	
			3	Dim: Right Groove Wall - Left Groove Wall	5.0000		+/- 0.0000	0%	5 Basic on Dwg	
			4	Profile: Edge Along Pt A			+/- 0.5000	50%	Profile 1, A (Lower Segment)	
			5	Datum Feature Shift			+/- 0.0000	0%	N/A	
Dimension Totals					5.0000	0.0000				
Nominal Distance: Pos Dims - Neg Dims =					5.0000					
<b>RESULTS:</b>							Nom	Tol	Min	Max
Arithmetic Stack (Worst Case)							5.0000	+/- 1.0000	4.0000	6.0000
Statistical Stack (RSS)							5.0000	+/- 0.7071	4.2929	5.7071
Adjusted Statistical: 1.5*RSS							5.0000	+/- 1.0607	3.9393	6.0607
Notes:										



### Positional Tolerances

- Positional tolerances can also be translated into  $\pm$  tolerances: MMC, LMC, RFS
- Positional tolerances specify a cylindrical or total width tolerance zone for features of size (FOS)

# Chapter #9 Geometric Dimensioning and Tolerancing

## Positional Tolerances: MMC

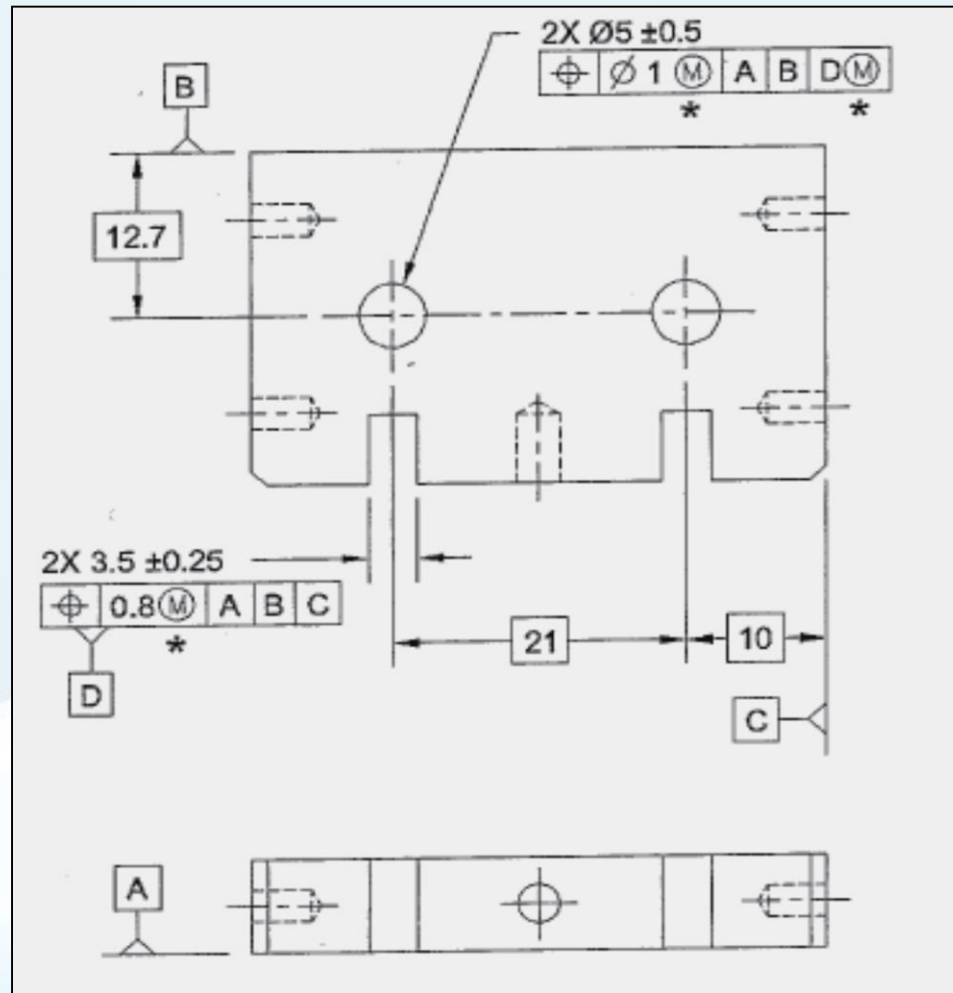

# Chapter #9 Geometric Dimensioning and Tolerancing

## Positional Tolerances: RFS, MMC, LMC

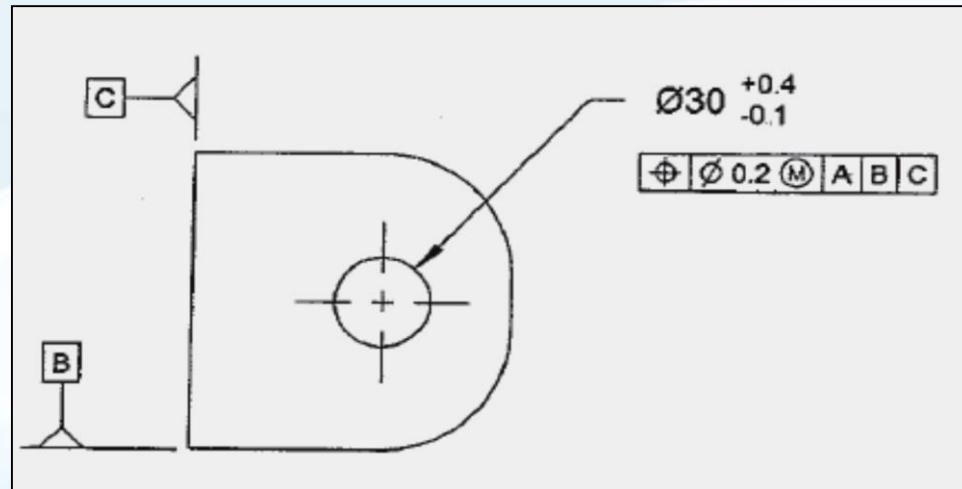
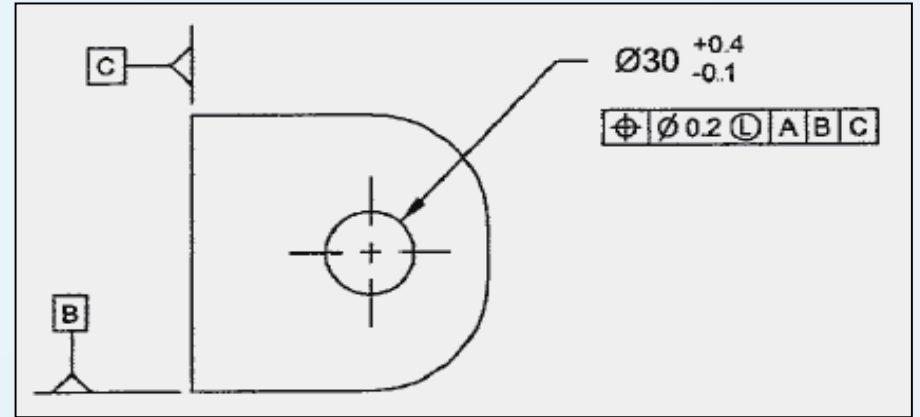
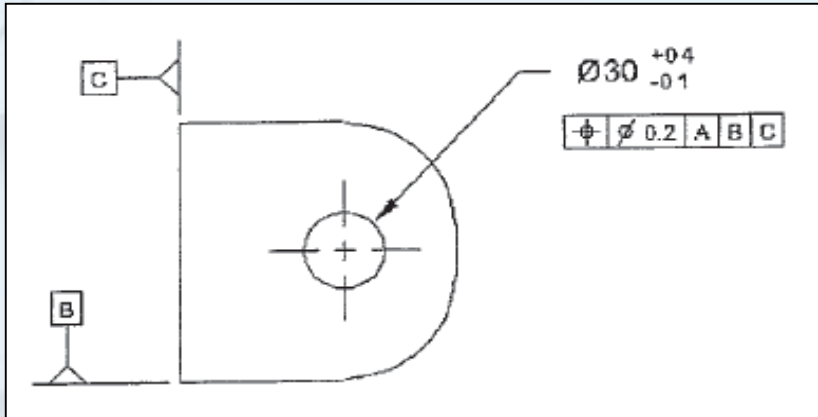

# Chapter #9 Geometric Dimensioning and Tolerancing

## Positional Tolerance, Assembly Shift, And Misalignment

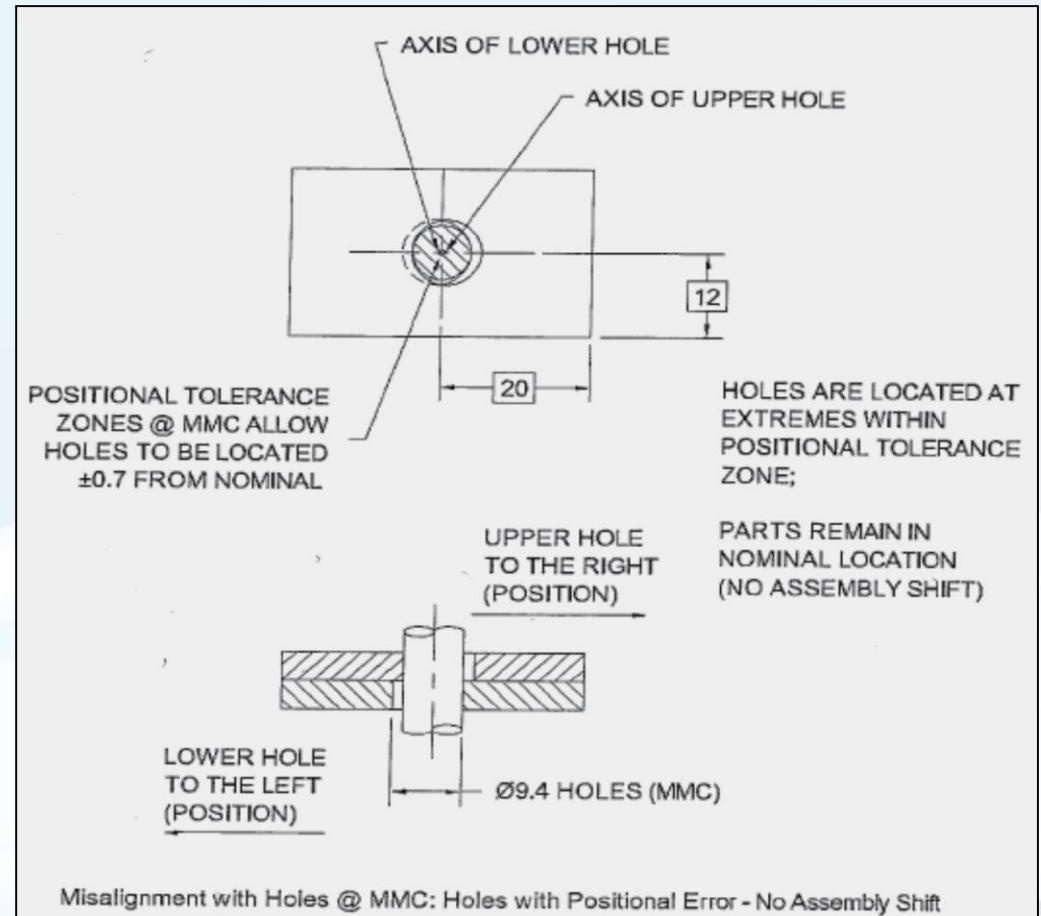
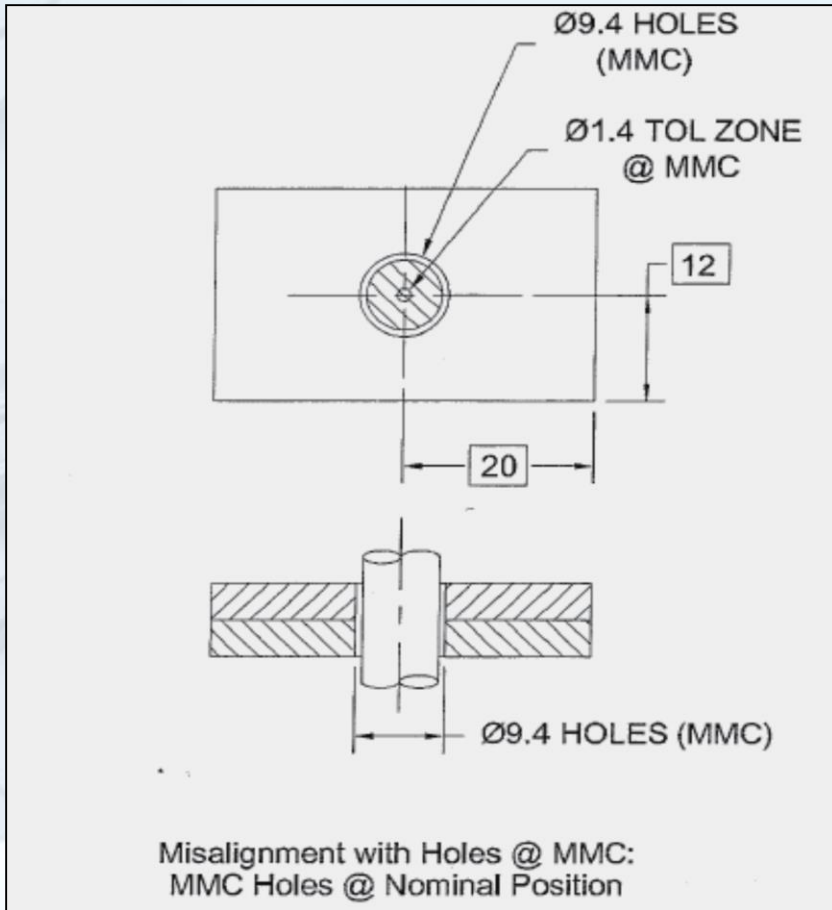

## Chapter #9 Geometric Dimensioning and Tolerancing

### Positional Tolerance, Assembly Shift, And Misalignment

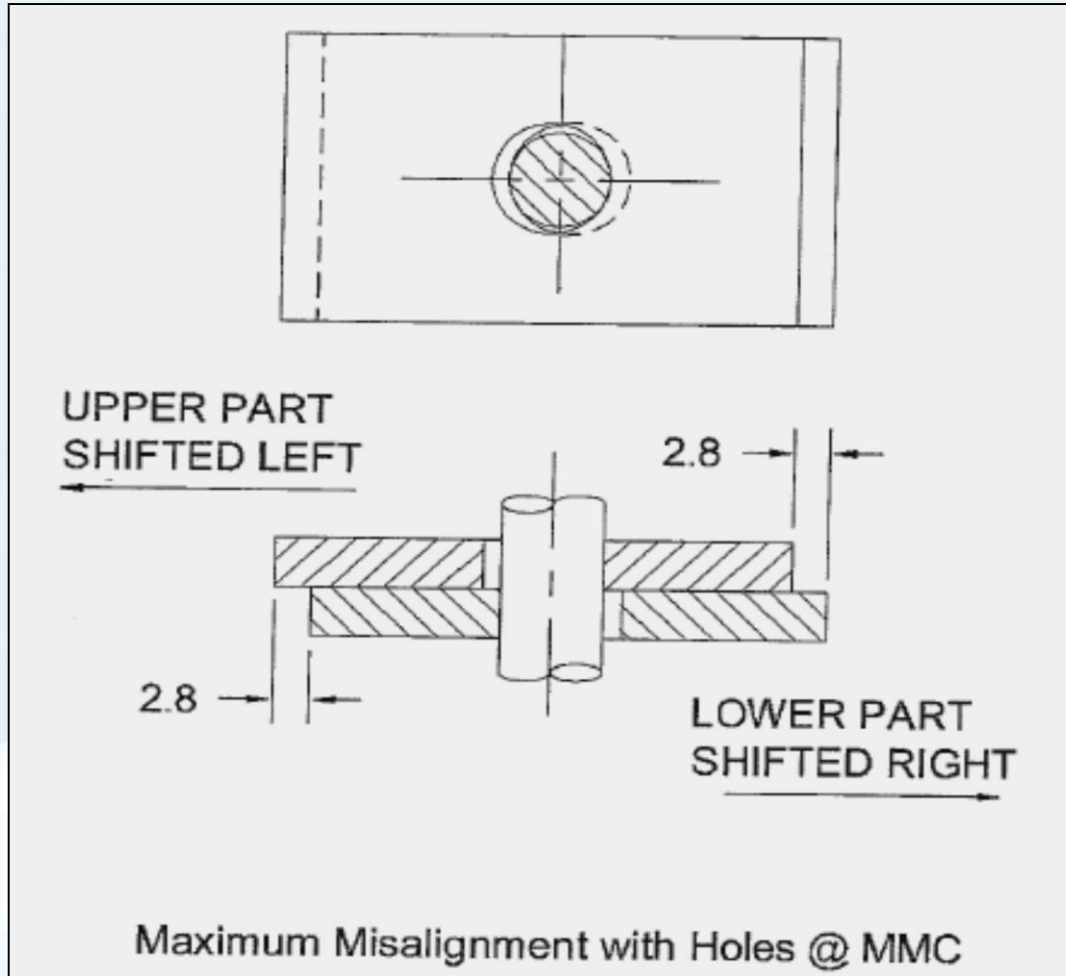





## Chapter #9 Geometric Dimensioning and Tolerancing

### Positional Tolerance, Assembly Shift, And Misalignment

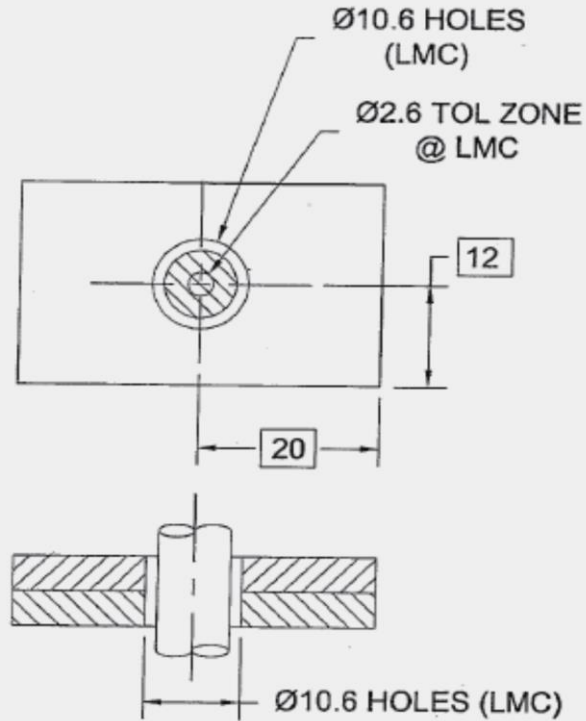
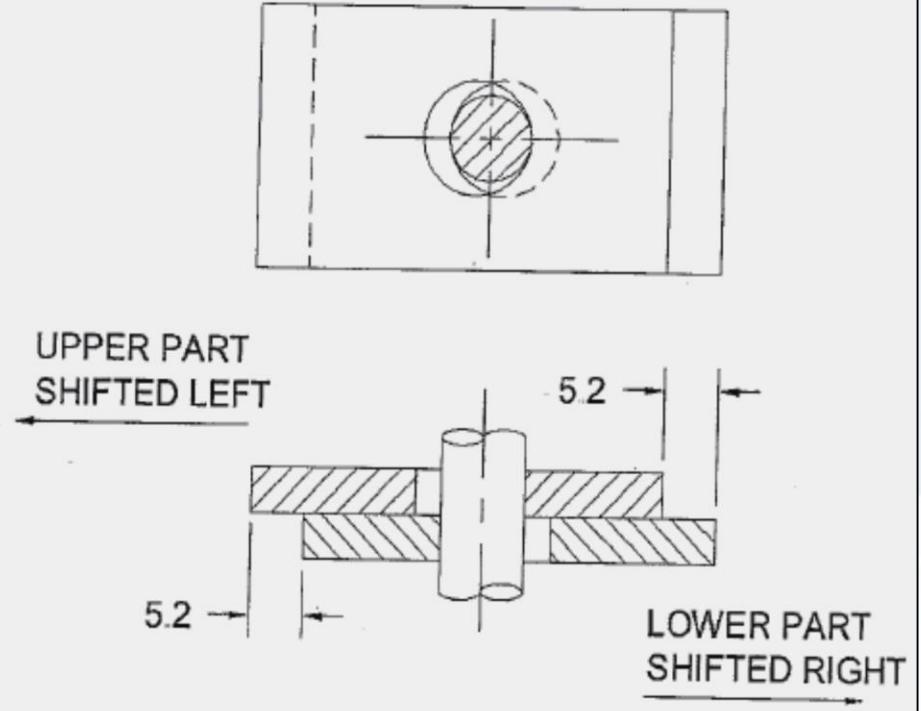

FIGURE 9.21 Misalignment with holes at LMC #1, nominal.



Maximum Misalignment with Holes @ LMC

## Chapter #9 Geometric Dimensioning and Tolerancing

### Positional Tolerance, Assembly Shift, And Misalignment

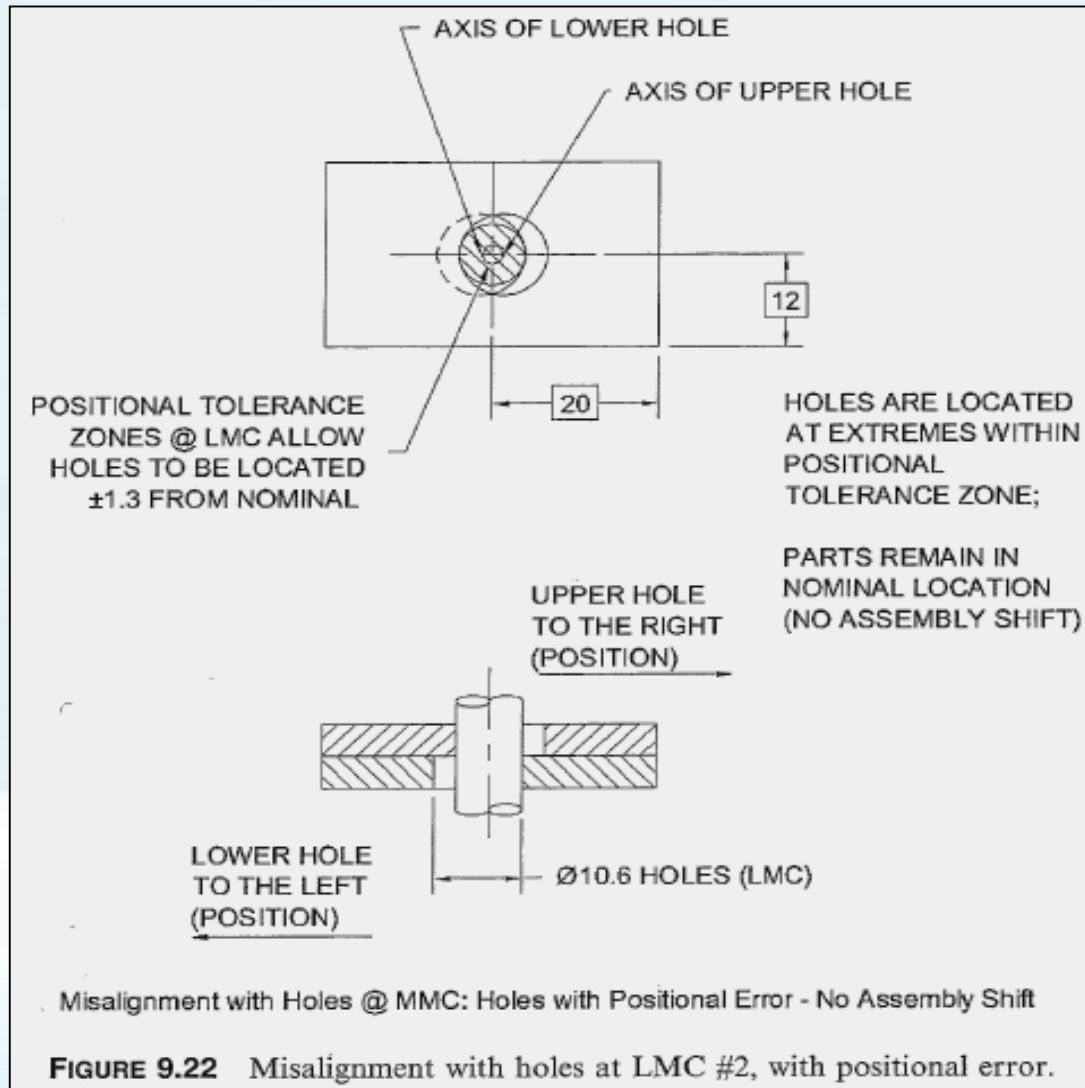

# Chapter #9 Geometric Dimensioning and Tolerancing

## Positional Tolerance, Assembly Shift, And Misalignment

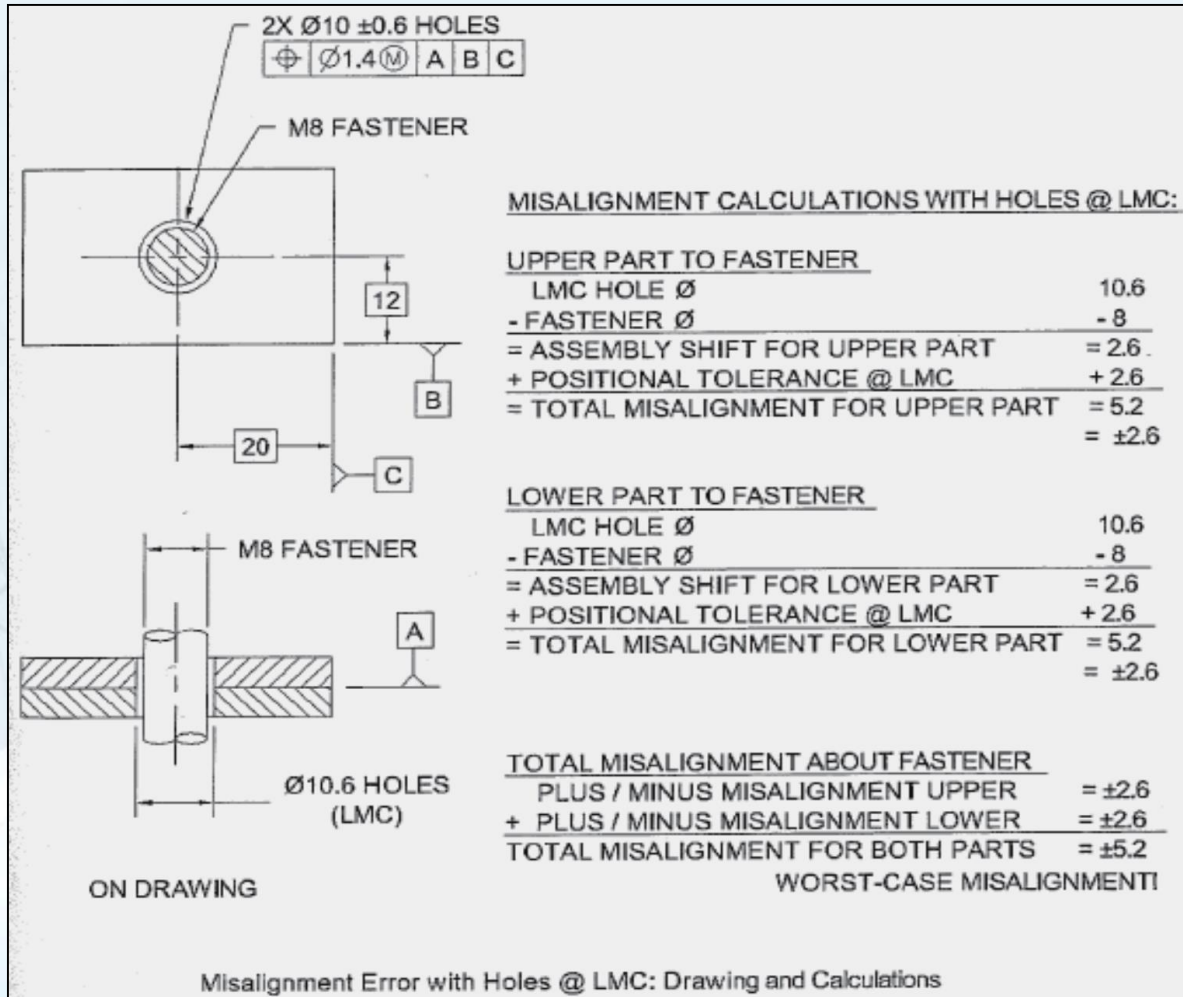

## Positional Tolerance Example #9.1

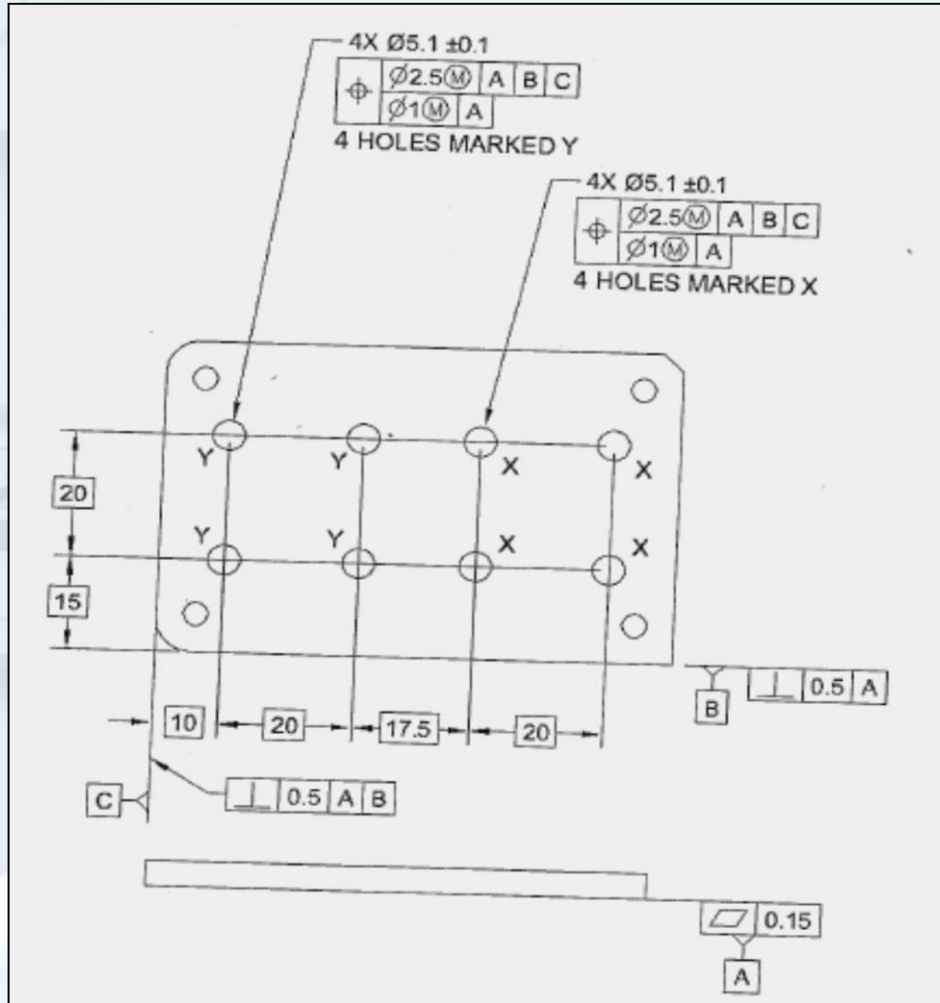
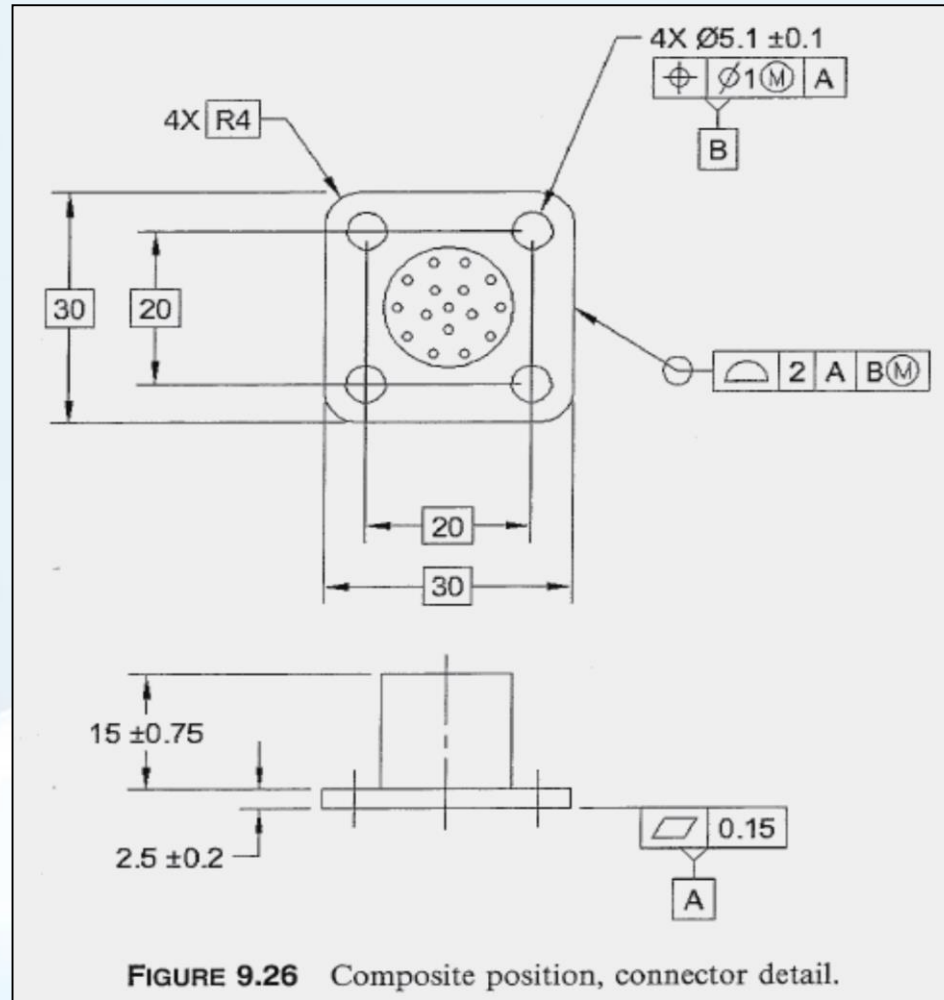

FIGURE 9.25 Composite position back panel detail: Option 1. In this example, each four hole pattern has its own composite position feature control frame. Using this method makes the two patterns distinct.

## Chapter #9 Geometric Dimensioning and Tolerancing

### Positional Tolerance Example #9.1



### Positional Tolerance Example #9.1

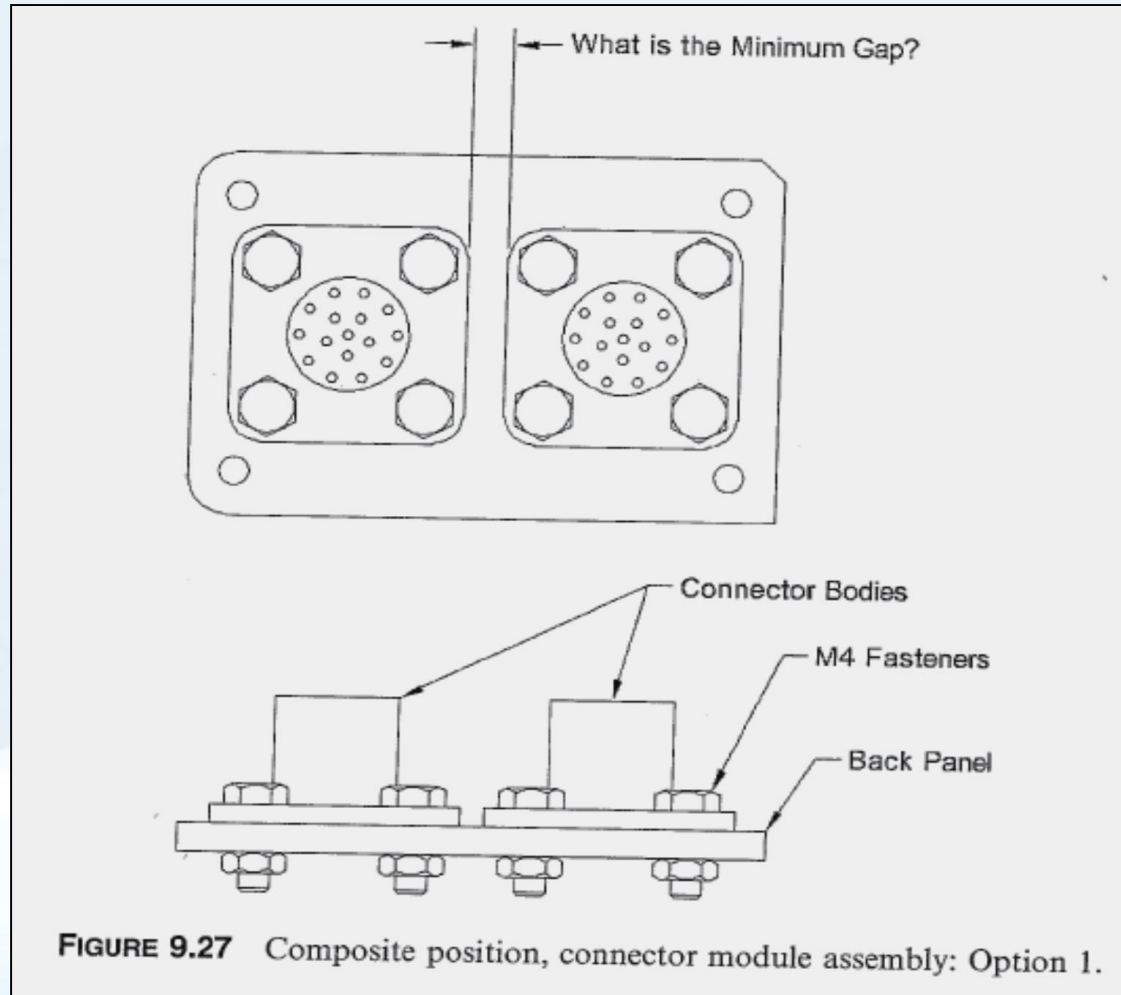



# Chapter #9 Geometric Dimensioning and Tolerancing

## Positional Tolerance Example #9.1

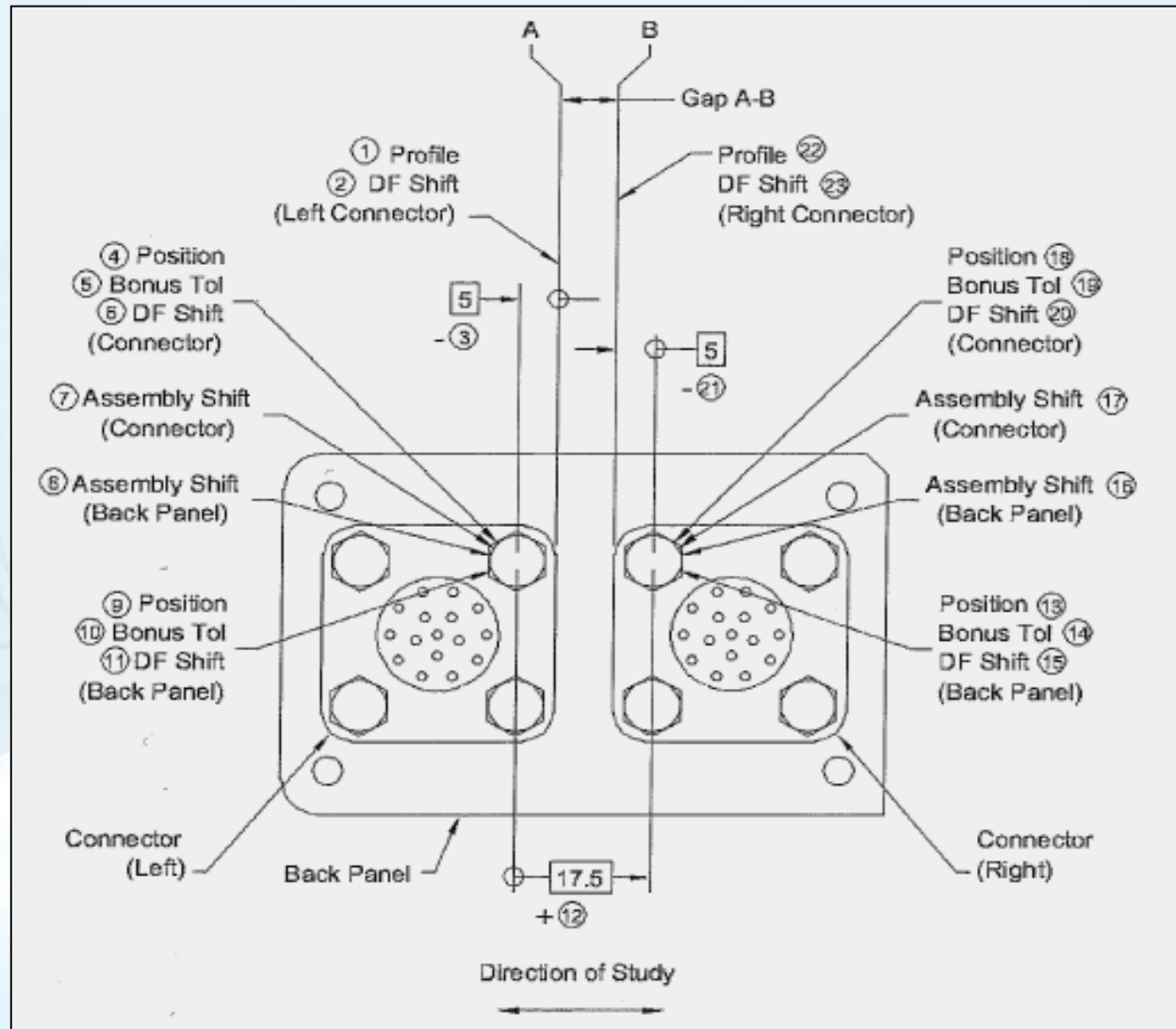

# Chapter #9 Geometric Dimensioning and Tolerancing

## Positional Tolerance Example #9.1

Program:		Tolerance Analysis and Stackup Manual		Release 1.2a	
Product:		Part Number Rev Description		Stack Information:	
		Opt-1 A Connector Module Assembly; Option 1		Stack No: Figure 9-29	
Problem:		The Connectors Must not Contact Each Other at Assembly		Date: 07/04/02	
Objective:		Determine if Connectors Make Contact at Assembly		Revision: A	
				Direction: Horizontal	
				Author: BR Fischer	

Description of Component / Assy	Part Number	Rev	Item	Description	+ Dims	- Dims	Tol	Percent Contrib	Dim / Tol Source & Calcs
Connector (Left)	123-002	A	1	Profile: Edge Along Pt A			±0.0000	12.0%	Profile 2, A, Bm
			2	Datum Feature Shift: $(DF_{A @ MMC} - DFS_A) / 2$			±0.6000	7.2%	$= (5.1 + 0.1 - (5.1 - 0.1 - 1)) / 2$
			3	Dim: Edge of Connector - Datum B			±0.0000	0%	$= (30 \text{ Basic} - 20 \text{ Basic}) / 2$ on Dwg
			4	Position: $DF_B$ Holes	5.0000		±0.0000	0%	N/A - (See Note 3)
			5	Bonus Tolerance			±0.0000	0%	N/A - (See Note 3)
			6	Datum Feature Shift			±0.0000	0%	N/A - $DF_A$ not a Feature of Size
			7	Assembly Shift: $(Mounting Holes_{MMC} - F) / 2$			±0.6000	7.2%	$= ((5.1 + 0.1) - 4) / 2$ (See Note 2)
Back Panel	123-001	A	8	Assembly Shift: $(Mounting Holes_{MMC} - F) / 2$			±0.6000	7.2%	$= ((5.1 + 0.1) - 4) / 2$ (See Note 2)
			9	Position (Holes on Left)			±1.2500	15.1%	Position dia 2.5 @ MMC A, B, C (Upper Segment)
			10	Bonus Tolerance			±0.1000	1.2%	$= (0.1 + 0.1) / 2$
			11	Datum Feature Shift			±0.0000	0.0%	N/A - (See Note 1)
			12	Dim: CL Left Holes - CL Right Holes	17.5000		±0.0000	0%	17.5 Basic on Dwg
			13	Position (Holes on Right)			±1.2500	15.1%	Position dia 2.5 @ MMC A, B, C (Upper Segment)
			14	Bonus Tolerance			±0.1000	1.2%	$= (0.1 + 0.1) / 2$
Connector (Right)	123-002	A	15	Datum Feature Shift			±0.0000	0.0%	N/A - (See Note 1)
			16	Assembly Shift: $(Mounting Holes_{MMC} - F) / 2$			±0.6000	7.2%	$= ((5.1 + 0.1) - 4) / 2$ (See Note 2)
			17	Assembly Shift: $(Mounting Holes_{MMC} - F) / 2$			±0.6000	7.2%	$= ((5.1 + 0.1) - 4) / 2$ (See Note 2)
			18	Position: $DF_B$ Holes			±0.0000	0%	N/A - (See Note 3)
			19	Bonus Tolerance			±0.0000	0%	N/A - (See Note 3)
			20	Datum Feature Shift			±0.0000	0%	N/A - $DF_A$ not a Feature of Size
			21	Dim: Datum B - Edge of Connector			±0.0000	0%	$= (30 \text{ Basic} - 20 \text{ Basic}) / 2$ on Dwg
22	Profile: Edge Along Pt B			±0.0000	0%	Profile 2, A, Bm			
23	Datum Feature Shift: $(DF_{A @ MMC} - DFS_A) / 2$			±0.6000	7.2%	$= (5.1 + 0.1 - (5.1 - 0.1 - 1)) / 2$			
Dimension Totals					17.5000	10.0000			
Nominal Distance: Pos Dims - Neg Dims =						7.5000			

RESULTS:	Nom	Tol	Min	Max
Arithmetic Stack (Worst Case)	7.5000	±0.9000	-0.0000	15.8000
Statistical Stack (RSS)	7.5000	±0.27028	4.7972	10.2028
Adjusted Statistical: 1.5 * RSS	7.5000	±0.40542	3.4456	11.5542

**Notes:**

- Datum Feature Shift is not included for the Back Panel in this Tolerance Stackup because Datum Features A, B & C are not Features of Size.
- M4 Screw Dimensions: Used 4mm as Major Diameter of Threads
- The Positional Tolerance on the Connector's Datum Feature B Holes does not contribute to the Stackup. Because the holes are the secondary Datum Feature, they are the basis from which all other features on the part are located in the direction of the Stackup.

**Assumptions:**

**Suggested Action:**

- Using the tolerance in the Upper Segment on Lines 9 & 13, the worst-case Tolerance Stackup result is 0.8 interference.

FIGURE 9-29

## Positional Tolerance Example #9.2

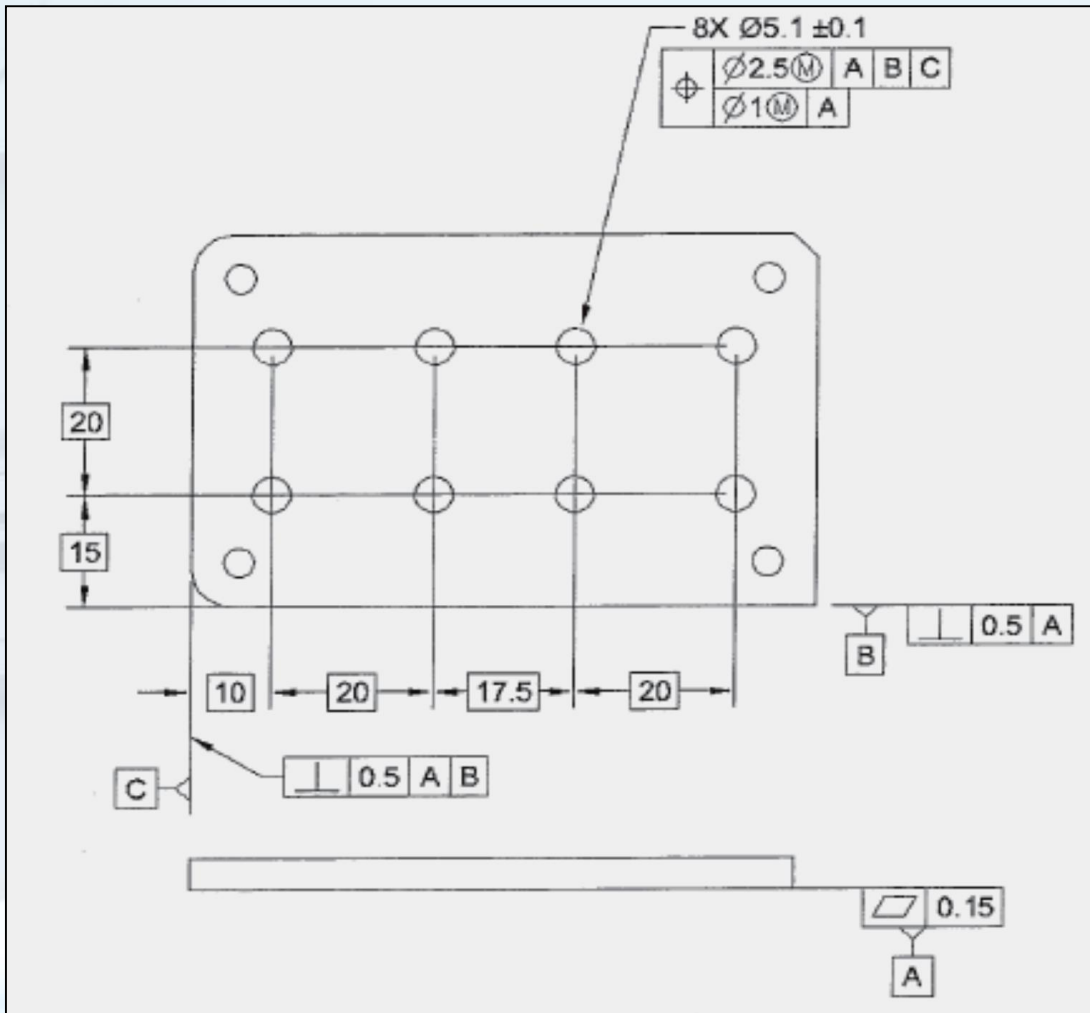

FIGURE 9.30 Composite Position, back panel detail: Option 2. In this example, all eight holes are toleranced with a single Composite Position Feature Control Frame. Using this method treats the two patterns as a single pattern.

## Positional Tolerance Example #9.2

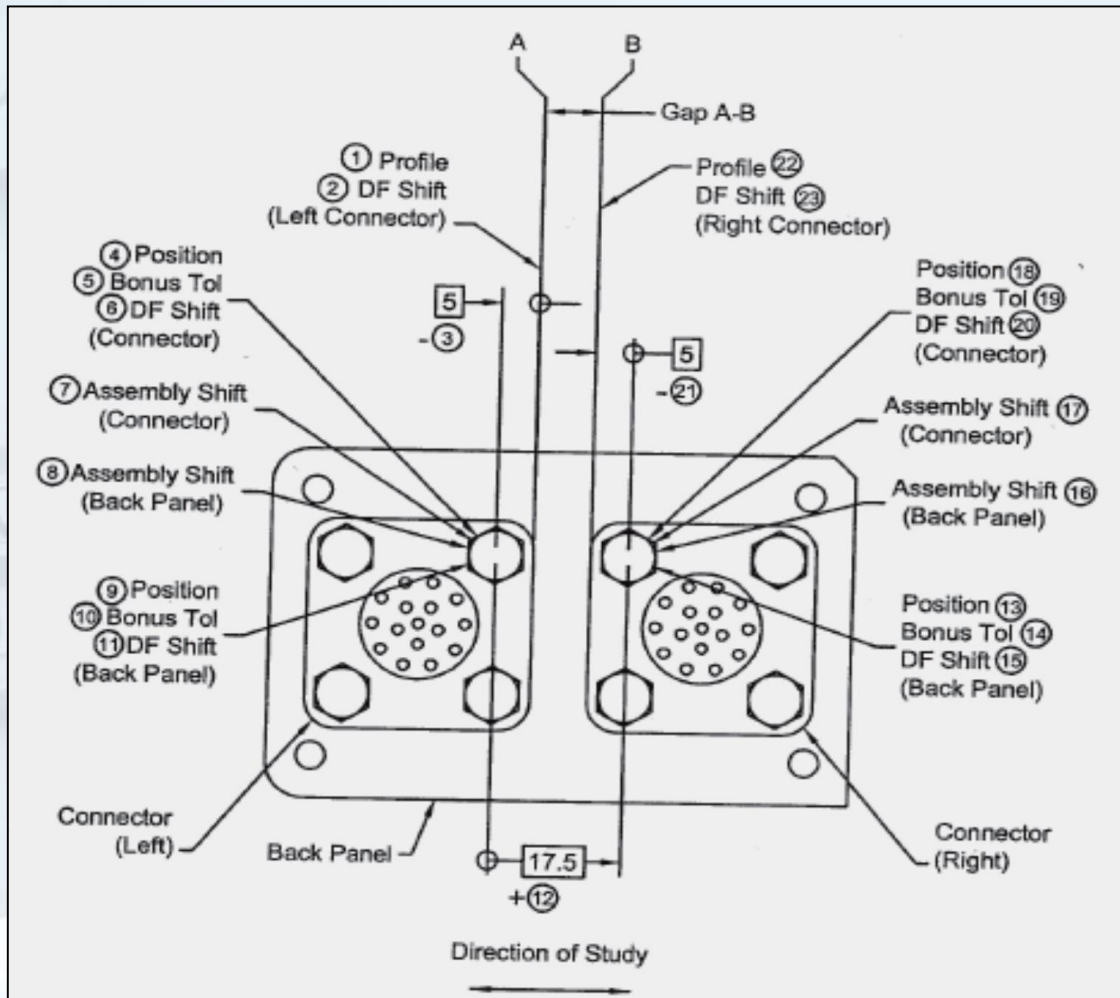

FIGURE 9.31 Composite Position: Option 2 Tolerance Stack up sketch.

Tolerance Stack up with Option 1 Back Panel:

Chain of Dimensions and Tolerances

Lower Segment Tolerances Used for Line Items 9 & 13



# Chapter #9 Geometric Dimensioning and Tolerancing

## Positional Tolerance Example #9.2

Program: Tolerance Analysts and Stackup Manual					Stack Information				
Product: Opt-2 A Connector Module Assembly, Option 2					Stack No: Figure 9-32				
Problem: The Connectors Must not Contact Each Other at Assembly					Date: 07/04/02				
Objective: Determine if Connectors Make Contact at Assembly					Revision: A				
					Direction: Horizontal				
					Author: BR Fischer				
Description of Component / Assy	Part Number	Rev	Item	Description	+ Dims	- Dims	Tol	Percent Contrib	Dim / Tol Source & Calcs
Connector (Left)	123-002	A	1	Profile: Edge Along Pt A			+/- 1.0000	14.7%	Profile 2, A, Bm
			2	Datum Feature Shift: $(DF_B @ MMC - DFS_B) / 2$			+/- 0.6000	8.8%	$= (5.1 + 0.1 - (5.1 - 0.1 - 1)) / 2$
			3	Dim: Edge of Connector - Datum B		5.0000	+/- 0.0000	0%	$= (30 \text{ Basic} - 20 \text{ Basic}) / 2$ on Dwg
			4	Position: $DF_B$ Holes			+/- 0.0000	0%	N/A - (See Note 3)
			5	Bonus Tolerance			+/- 0.0000	0%	N/A - (See Note 3)
			6	Datum Feature Shift			+/- 0.0000	0%	N/A - $DF_A$ not a Feature of Size
			7	Assembly Shift: $(\text{Mounting Holes}_{MMC} - F) / 2$			+/- 0.6000	8.8%	$= ((5.1 + 0.1) - 4) / 2$ (See Note 2)
Back Panel	123-001	A	8	Assembly Shift: $(\text{Mounting Holes}_{MMC} - F) / 2$			+/- 0.6000	8.8%	$= ((5.1 + 0.1) - 4) / 2$ (See Note 2)
			9	Position (Holes on Left)			+/- 0.5000	7.4%	Position dia 1 @ MMC A (Lower Segment)
			10	Bonus Tolerance			+/- 0.1000	1.5%	$= (0.1 + 0.1) / 2$
			11	Datum Feature Shift			+/- 0.0000	0.0%	N/A - (See Note 1)
			12	Dim: CL Left Holes - CL Right Holes	17.5000		+/- 0.0000	0%	17.5 Basic on Dwg
			13	Position (Holes on Right)			+/- 0.5000	7.4%	Position dia 1 @ MMC A (Lower Segment)
			14	Bonus Tolerance			+/- 0.1000	1.5%	$= (0.1 + 0.1) / 2$
			15	Datum Feature Shift			+/- 0.0000	0.0%	N/A - (See Note 1)
			16	Assembly Shift: $(\text{Mounting Holes}_{MMC} - F) / 2$			+/- 0.6000	8.8%	$= ((5.1 + 0.1) - 4) / 2$ (See Note 2)
Connector (Right)	123-002	A	17	Assembly Shift: $(\text{Mounting Holes}_{MMC} - F) / 2$			+/- 0.6000	8.8%	$= ((5.1 + 0.1) - 4) / 2$ (See Note 2)
			18	Position: $DF_B$ Holes			+/- 0.0000	0%	N/A - (See Note 3)
			19	Bonus Tolerance			+/- 0.0000	0%	N/A - (See Note 3)
			20	Datum Feature Shift			+/- 0.0000	0%	N/A - $DF_A$ not a Feature of Size
			21	Dim: Datum B - Edge of Connector		5.0000	+/- 0.0000	0%	$= (30 \text{ Basic} - 20 \text{ Basic}) / 2$ on Dwg
			22	Profile: Edge Along Pt B			+/- 1.0000	14.7%	Profile 2, A, Bm
			23	Datum Feature Shift: $(DF_B @ MMC - DFS_B) / 2$			+/- 0.6000	8.8%	$= (5.1 + 0.1 - (5.1 - 0.1 - 1)) / 2$
Dimension Totals					17.5000	10.0000			
Nominal Distance: Pos Dims - Neg Dims =					7.5000				
<b>RESULTS:</b>					Norm	Tol	Min	Max	
Arithmetic Stack (Worst Case)					7.9000	+/- 6.8000	0.7000	14.9000	
Statistical Stack (RSS)					7.9000	+/- 2.1633	5.5367	9.6633	
Adjusted Statistical: 1.5RSS					7.9000	+/- 3.2450	4.2550	10.7450	
<b>Notes:</b>									
1 - Datum Feature Shift is not included for the Back Panel in this Tolerance Stackup because Datum Features A, B & C are not Features of Size.									
2 - M4 Screw Dimensions: Used 4mm as Major Diameter of Threads									
3 - The Positional Tolerance on the Connector's Datum Feature B Holes does not contribute to the Stackup. Because the holes are the secondary Datum Feature, they are the basis from which all other features on the part are located in the direction of the Stackup.									
<b>Assumptions:</b>									
<b>Suggested Action:</b>									
- Using the tolerance in the Lower Segment on Lines 9 & 13, the worst-case Tolerance Stackup result is 0.7 Clearance.									

## Positional Tolerance Example #9.3

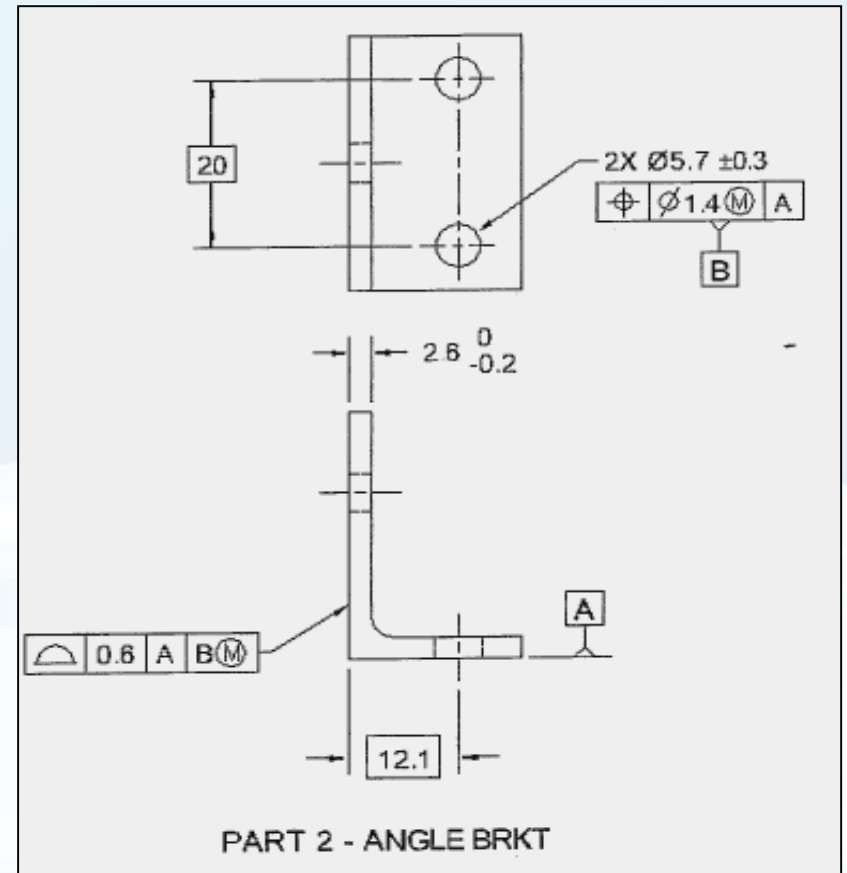
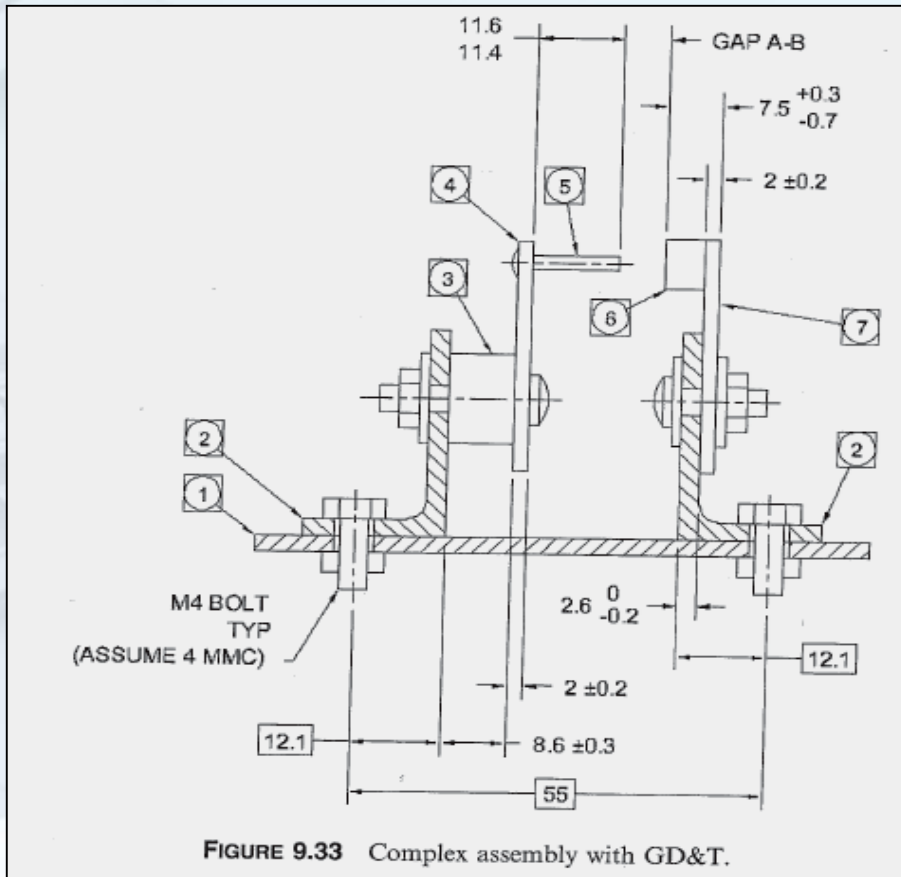



## Chapter #9 Geometric Dimensioning and Tolerancing

### Positional Tolerance Example #9.3

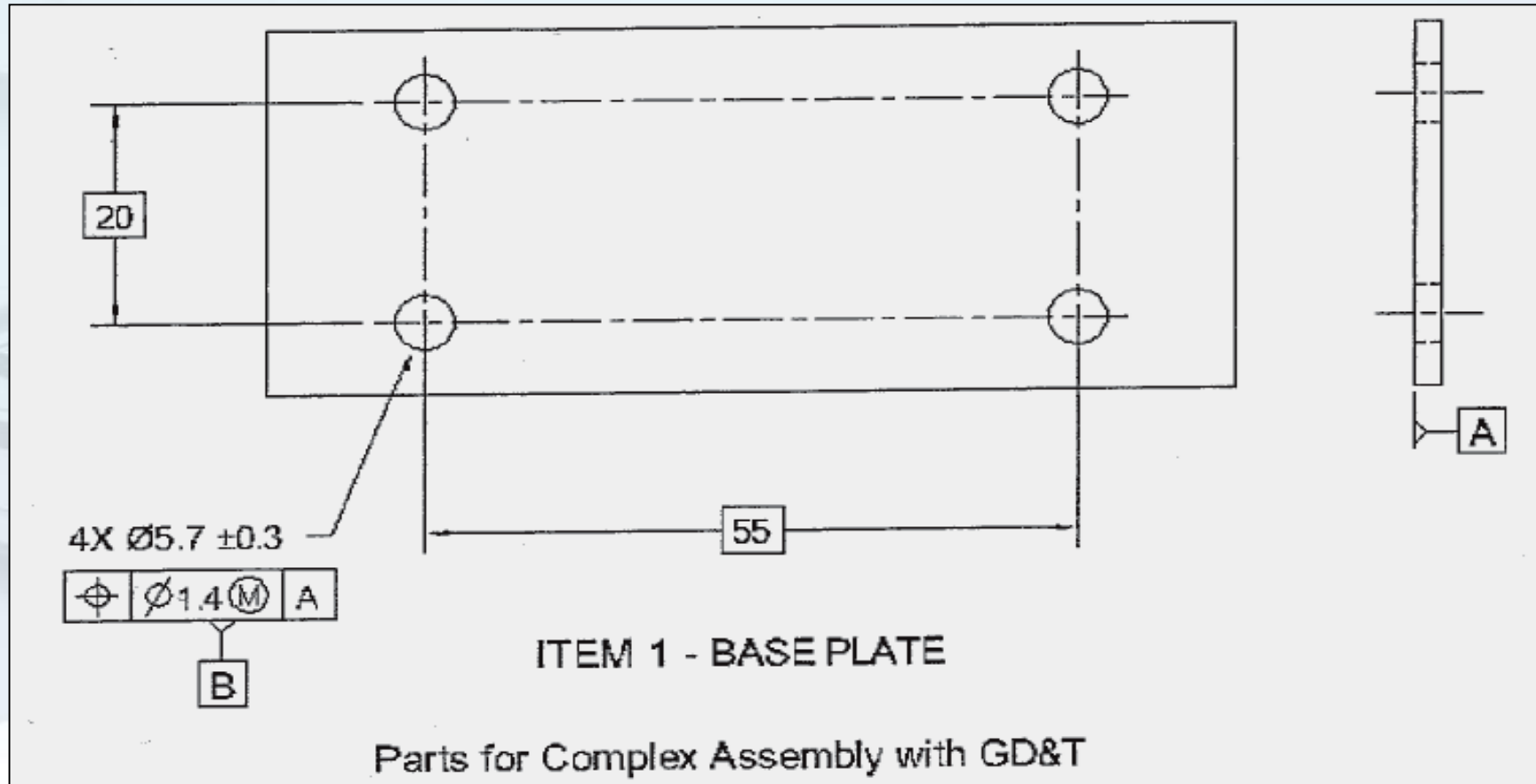

## Positional Tolerance Example #9.3

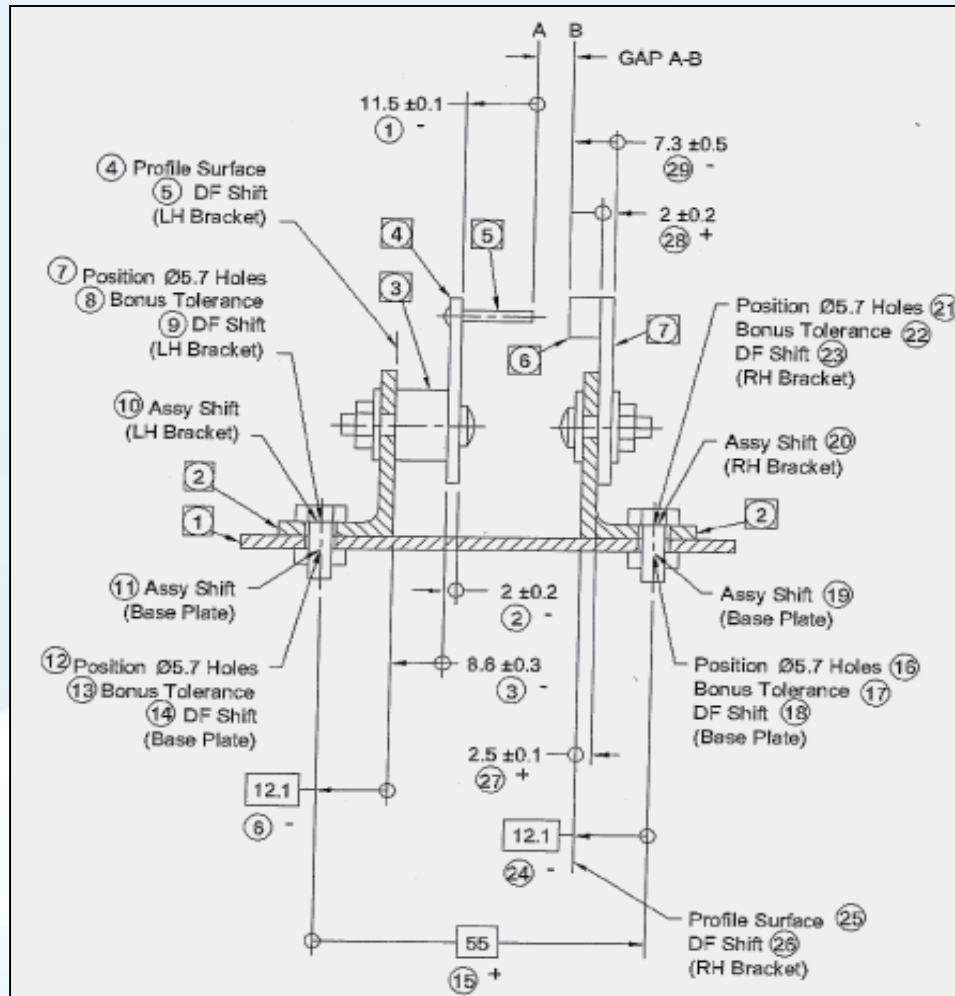

# Chapter #9 Geometric Dimensioning and Tolerancing

## Positional Tolerance Example #9.3

Dim No	Part No	+	-	+/-	Description
1	5		11.5	+/- 0.1	Dim: Pin Length
2	4		2	+/- 0.2	Dim: LH Plate Thickness
3	3		8.6	+/- 0.3	Standoff Thickness
4	2			+/- 0.3	Profile of Flange Face on LH Angle Brkt
5	2			+/- 1	Datum Feature Shift: $((5.7 + 0.3) - (5.7 - 0.3 - 1.4)) / 2 = +/-1$
6	2		12.1	+/- 0	Dim: Flange Face - CL DFB Holes on LH Angle Brkt (Basic)
7	2			+/- 0	Position of Dia 5.7 DF <sub>A</sub> Holes on LH Angle Brkt: N/A
8	2			+/- 0	Bonus Tolerance: N/A
9	2			+/- 0	Datum Feature Shift: N/A
10	2			+/- 1	Assembly Shift: LH Angle Brkt Holes @ LMC: $6(H) - 4(F) = 2 / 2 = +/-1$
11	1			+/- 1	Assembly Shift: Base Plate LH Holes @ LMC: $6(H) - 4(F) = 2 / 2 = +/-1$
12	1			+/- 0.7	Position of LH Dia 5.7 DF <sub>B</sub> Holes on Base Plate
13	1			+/- 0.3	Bonus Tolerance: $(0.3 + 0.3) / 2 = +/-0.3$
14	1			+/- 0	Datum Feature Shift: N/A - DF <sub>A</sub> not a Feature of Size
15	1	55		+/- 0	Dim: CL LH DF <sub>B</sub> Holes - CL RH DF <sub>B</sub> Holes on Base Plate (Basic)
16	1			+/- 0.7	Position of RH Dia 5.7 DF <sub>B</sub> Holes on Base Plate
17	1			+/- 0.3	Bonus Tolerance: $(0.3 + 0.3) / 2 = +/-0.3$
18	1			+/- 0	Datum Feature Shift: N/A - DF <sub>A</sub> not a Feature of Size
19	1			+/- 1	Assembly Shift: Base Plate LH Holes @ LMC: $6(H) - 4(F) = 2 / 2 = +/-1$
20	2			+/- 1	Assembly Shift: RH Angle Brkt Holes @ LMC: $6(H) - 4(F) = 2 / 2 = +/-1$
21	2			+/- 0	Position of Dia 5.7 DF <sub>B</sub> Holes on RH Angle Brkt: N/A
22	2			+/- 0	Bonus Tolerance: N/A
23	2			+/- 0	Datum Feature Shift: N/A
24	2		12.1	+/- 0	Dim: CL DFB Holes - Flange Face on RH Angle Brkt (Basic)
25	2			+/- 0.3	Profile of Flange Face on RH Angle Brkt
26	2			+/- 1	Datum Feature Shift: $((5.7 + 0.3) - (5.7 - 0.3 - 1.4)) / 2 = +/-1$
27	2	2.5		+/- 0.1	RH Angle Brkt Flange Thickness
28	7	2		+/- 0.2	Thickness of RH Plate
29	6 & 7		7.3	+/- 0.5	Thickness of RH Plate & Boss
		59.5	53.6	+/- 10	Worst Case Tolerance
				+/- 2.79	RSS Tolerance
				+/- 4.18	Adjusted RSS Tolerance (RSS * 1.5)
Positive Total		59.5			
Negative Total			-53.6		
Nominal Gap		5.9		+/- 4.18	Adjusted RSS Tolerance
Max Gap		10.08			Clearance
Min Gap			1.72		Clearance

### Positional Tolerance Summary

- Converting positional tolerances to equal bilateral  $\pm$  tolerances
- Positional tolerances are relatively easy to convert into equivalent  $\pm$  location tolerances.
- The method used to convert a positional tolerance depends on the material condition modifier (RFS, MMC, or LMC) applied to the tolerance and whether the tolerance is applied to features that affect the location of other features in the Tolerance Stack up.

### Composite Positional Tolerance

- The positional tolerance specified in the uppermost segment of the feature control frame represents the total allowable variation in location of the features to a datum reference frame.
- Typically the tolerance defined in the uppermost segment is used in Tolerance Stack ups.
- The tolerance zones defined in the lower segments of a composite feature control frame are not basically located to a datum reference frame— they may only be basically oriented to a datum reference frame and are basically located to each other in the case of a pattern.

### Composite Positional Tolerance

- both are included and formatted in the Tolerance Stack up report the same way as a single segment positional tolerance.
- Three lines are entered into the Tolerance Stack up report: the positional tolerance is entered on the first line, the bonus tolerance is entered on the second line, and datum feature shift is entered on the third line.
- The positional tolerance specified in a lower segment may be used in a Tolerance Stack up if the Tolerance Stack up is between features in a pattern. The positional tolerance specified in a lower segment may also be used with more advanced tolerancing techniques, such as when “simultaneous requirements” is explicitly stated



### Datum Feature Shift

- When datum features of size are referenced at MMC or LMC, their datum feature simulators may be smaller or larger than the datum features of size, which allows the part to shift or move relative to the datum feature simulators.
- The worst-case difference in size between the datum features and their simulators is the amount of datum feature shift.
- Datum shift means the datum features can shift during the inspection process—there is not a one-to-one relationship between the datum features and the datum feature simulators.

## Datum Feature Shift

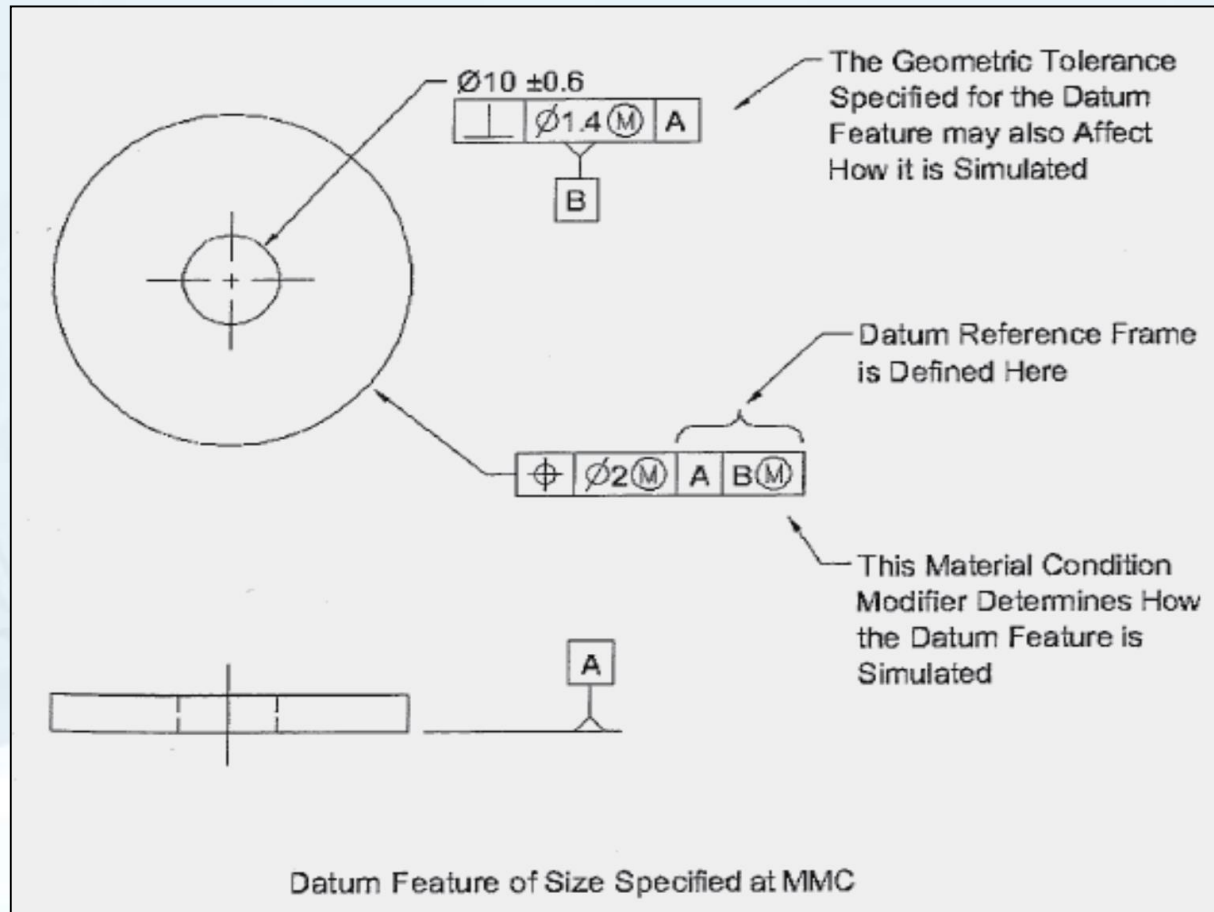

## Datum Feature Shift

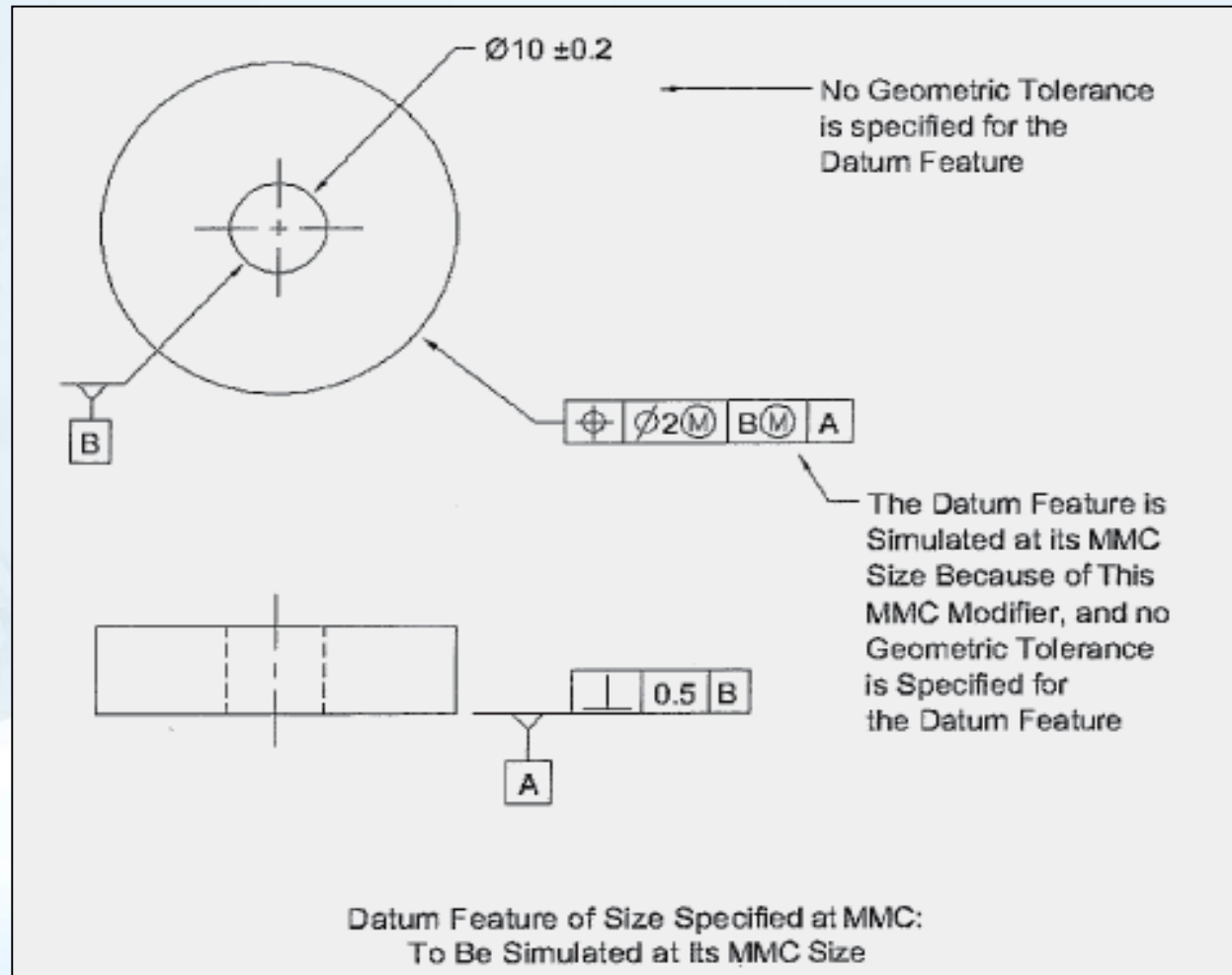

## Datum Feature Shift

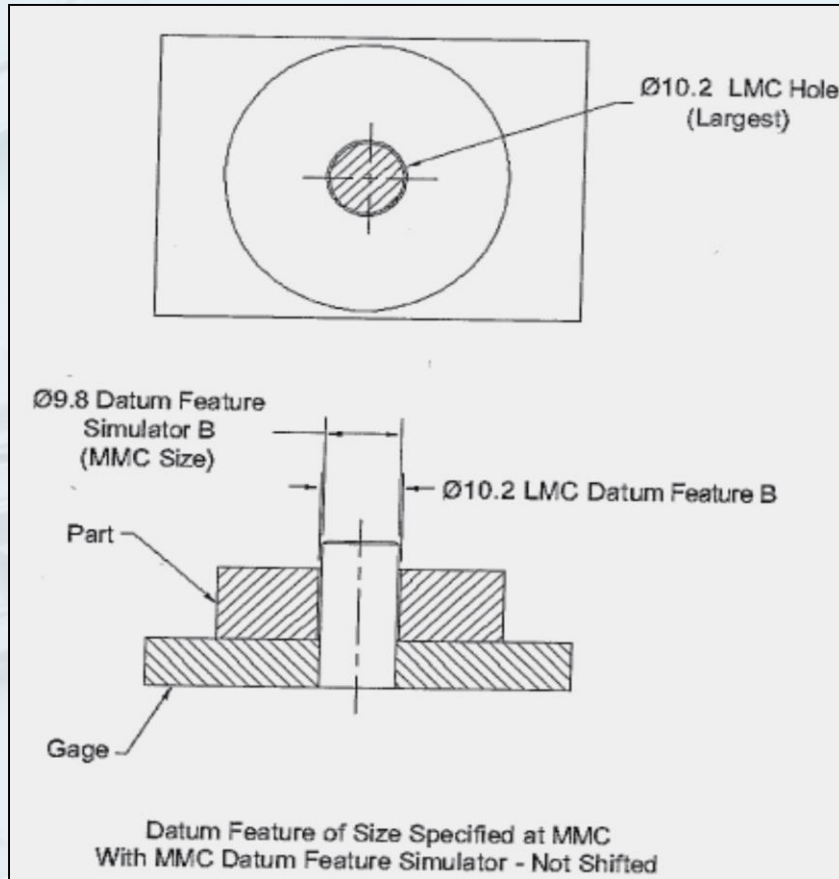

No Datum Shift

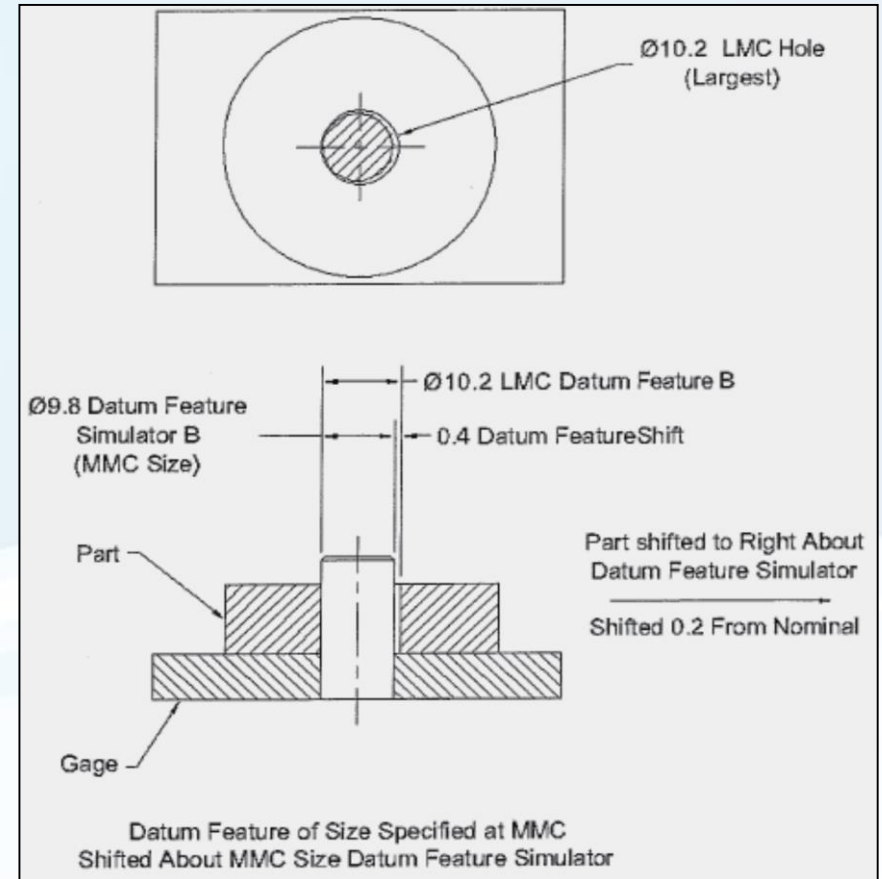

Datum Shift

### Datum Feature Shift

$$\begin{aligned} \text{MMC size} &= \text{Ø}10.0 \text{ nominal size} \\ &\quad \underline{-0.2 \text{ size tolerance}} \\ &= \text{Ø}9.8 \text{ MMC size} \end{aligned}$$

$$\begin{aligned} \text{LMC (largest) size of the hole} &= \text{Ø}10.0 \text{ nominal size} \\ &\quad \underline{+0.2 \text{ size tolerance}} \\ &= \text{Ø}10.2 \text{ LMC size} \end{aligned}$$

$$\begin{aligned} \text{Datum feature shift} &= \text{Ø}10.2 \text{ LMC Size} \\ &\quad \underline{-\text{Ø}9.8 \text{ MMC Size}} \\ &= 0.4 \text{ Datum Feature Shift} \end{aligned}$$

- Divide the datum feature shift by 2 =  $0.4/2 = \pm 0.2$ . This is the equal bilateral  $\pm$  equivalent

## Datum Feature Shift

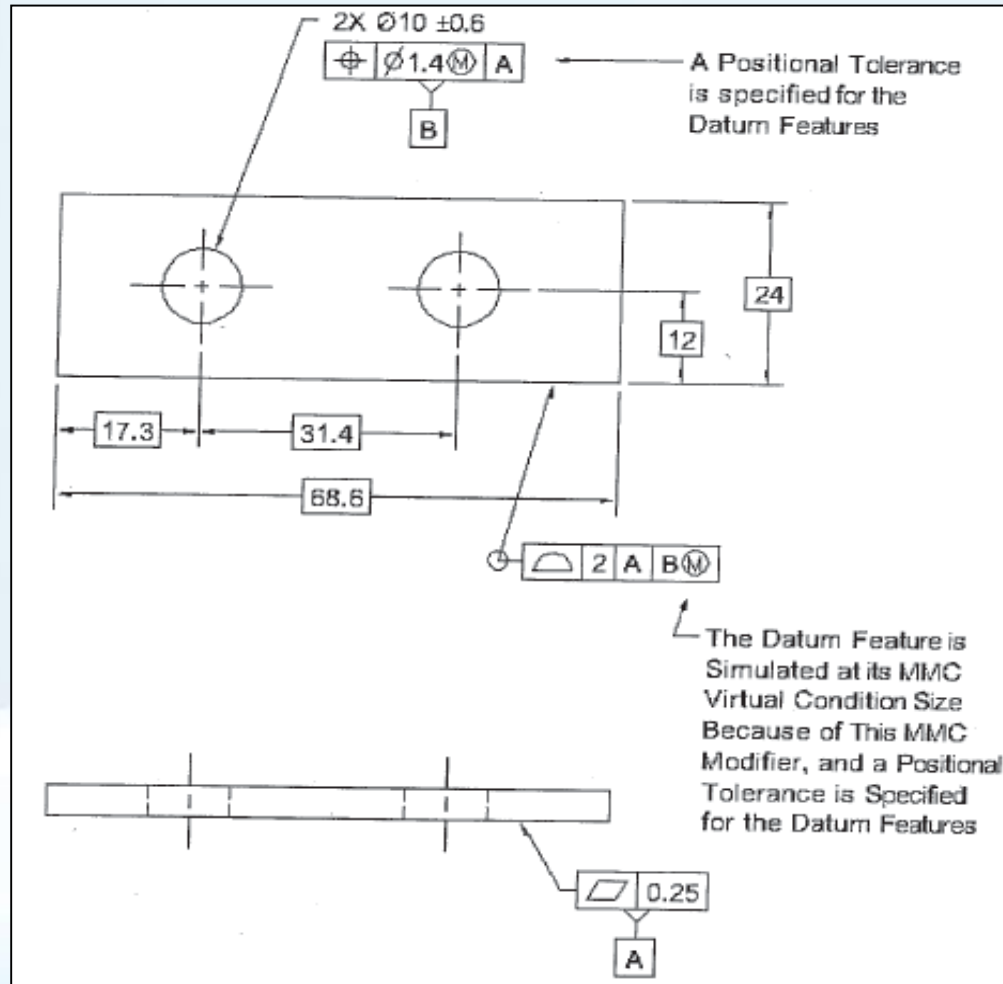



## Datum Feature Shift

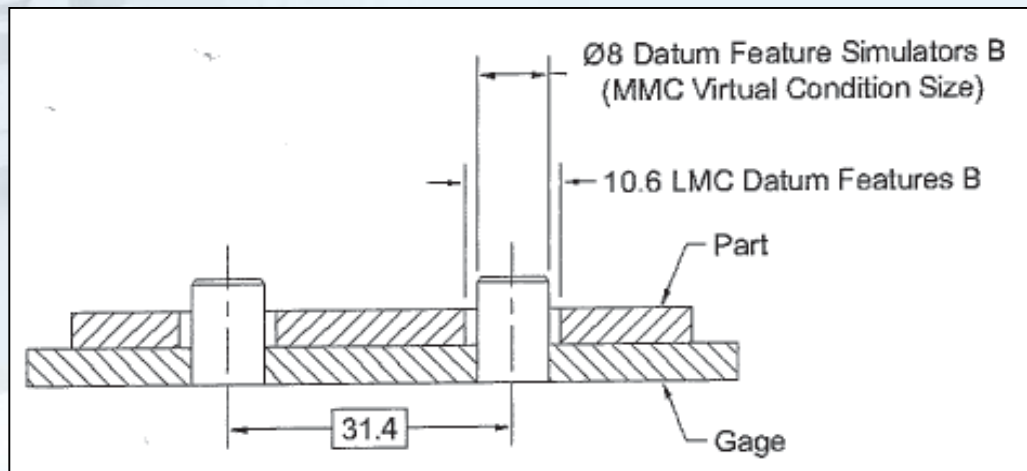
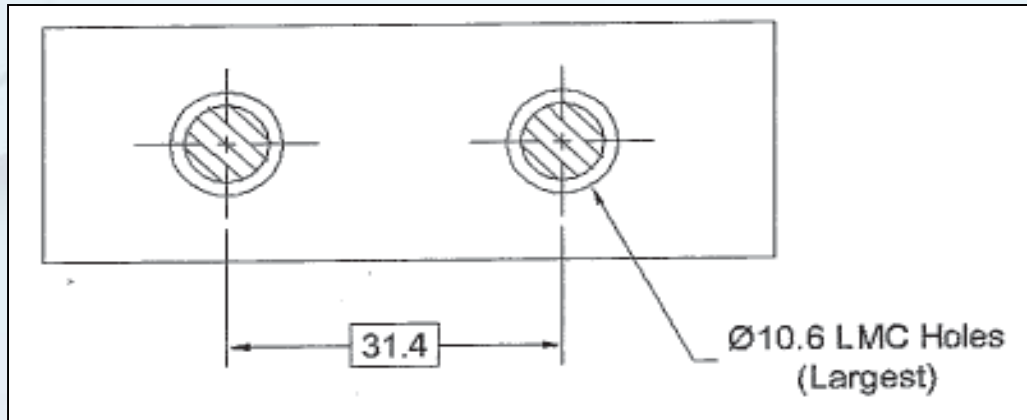

FIGURE 9.44 Datum feature shift: Datum feature of size to be simulated at MMC VC with datum feature simulator, no shift.

Datum Features of Size Referenced at MMC:

With MMC Virtual Condition Datum Feature Simulators - Not Shifted

## Datum Feature Shift

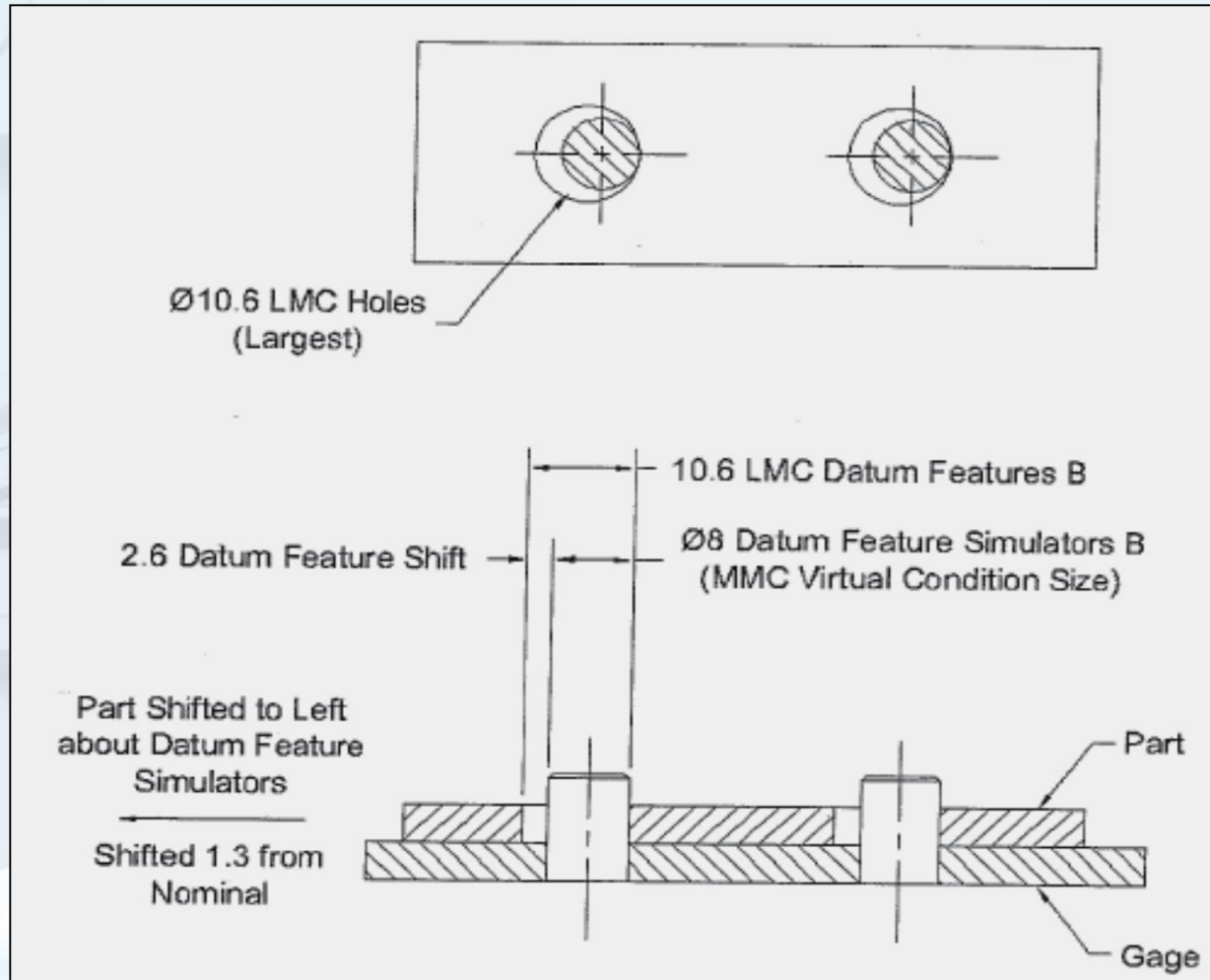

FIGURE 945 Datum feature shift: Datum feature of size to be simulated at MMC VC with datum feature simulator, shifted.

Datum Features of Size Referenced at MMC:  
Shifted About MMC Virtual Condition Datum Feature Simulators

### Simultaneous And Separate Requirements

- **Simultaneous Requirements**

Simultaneous requirements is the default condition for drawings prepared using the ASME Y14.5M-1994 standard. Unless specified otherwise, simultaneous requirements applies to all single segment feature control frames and the uppermost segment of all composite feature control frames related to the same datum reference frame.

The same datum reference frame means the same datum features are accompanied by the same modifiers referenced in exactly the same order of precedence in each feature control frame. This includes material condition modifiers and other modifiers.

# Chapter #9 Geometric Dimensioning and Tolerancing

## Simultaneous Requirements

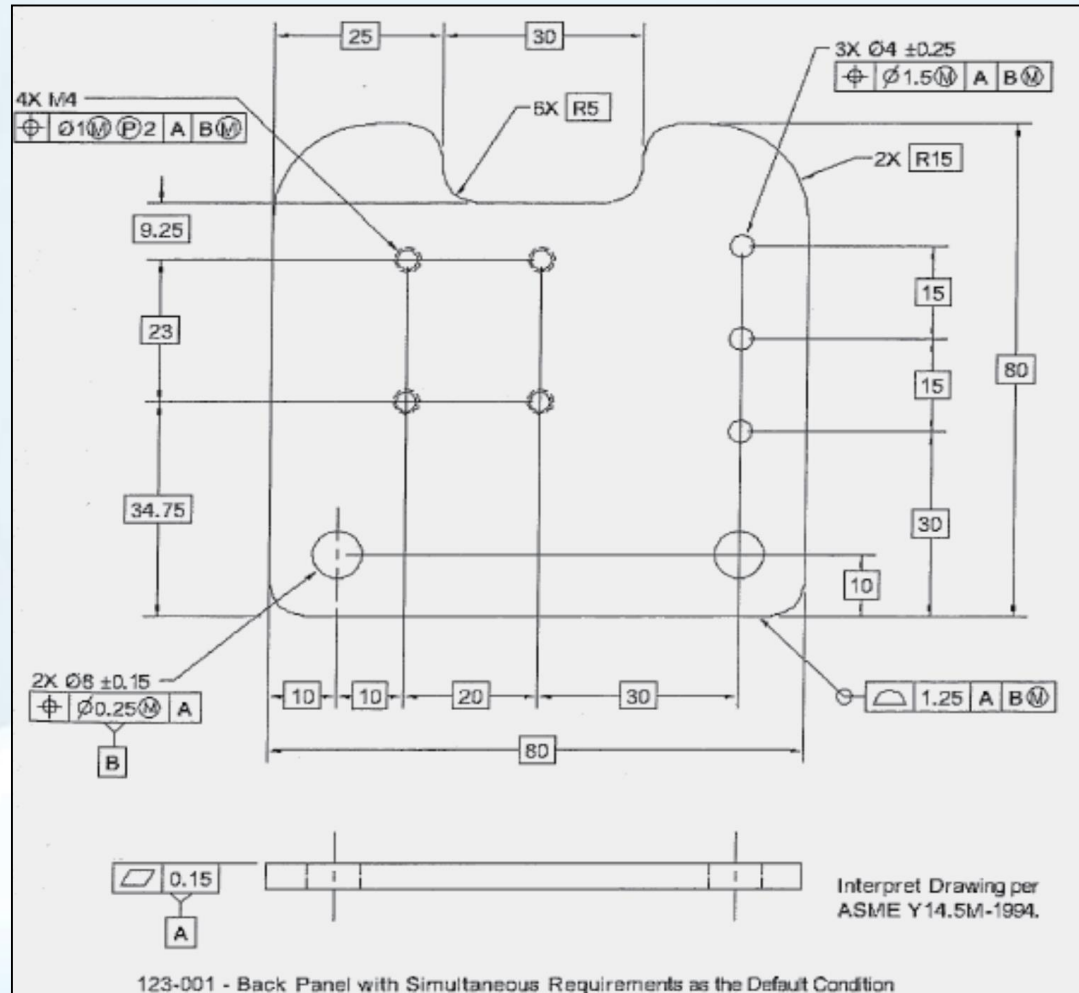

# Chapter #9 Geometric Dimensioning and Tolerancing

## Assembly With Switch Carrier

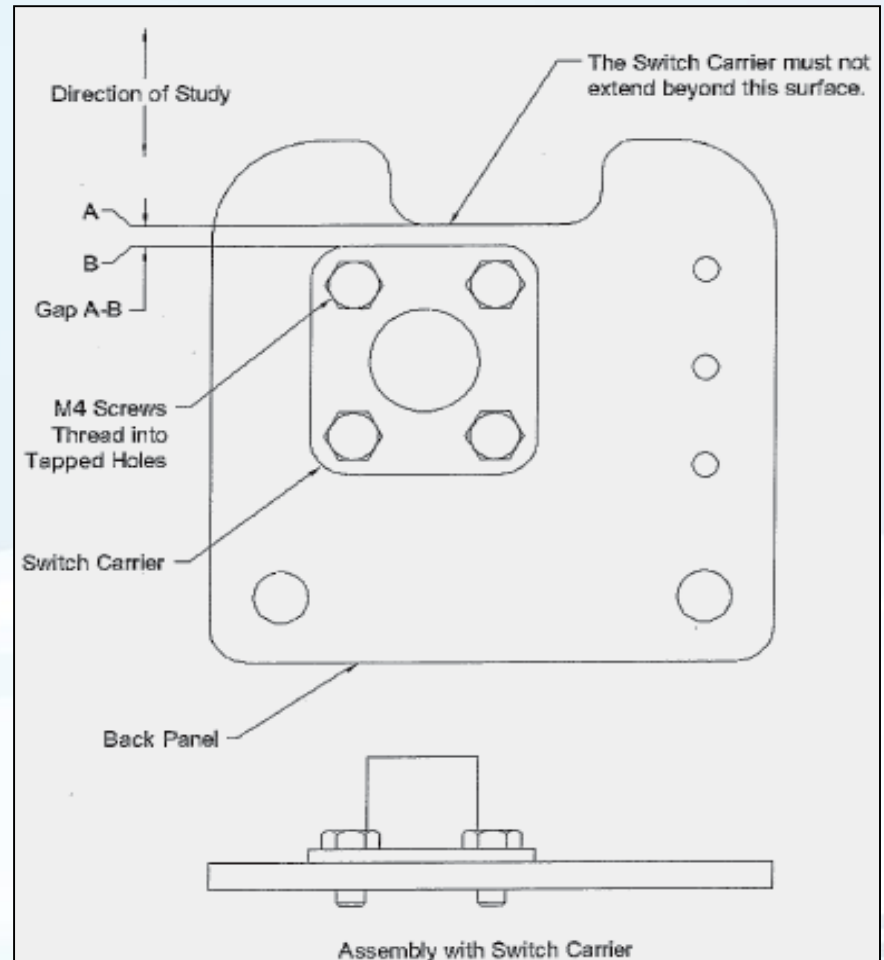
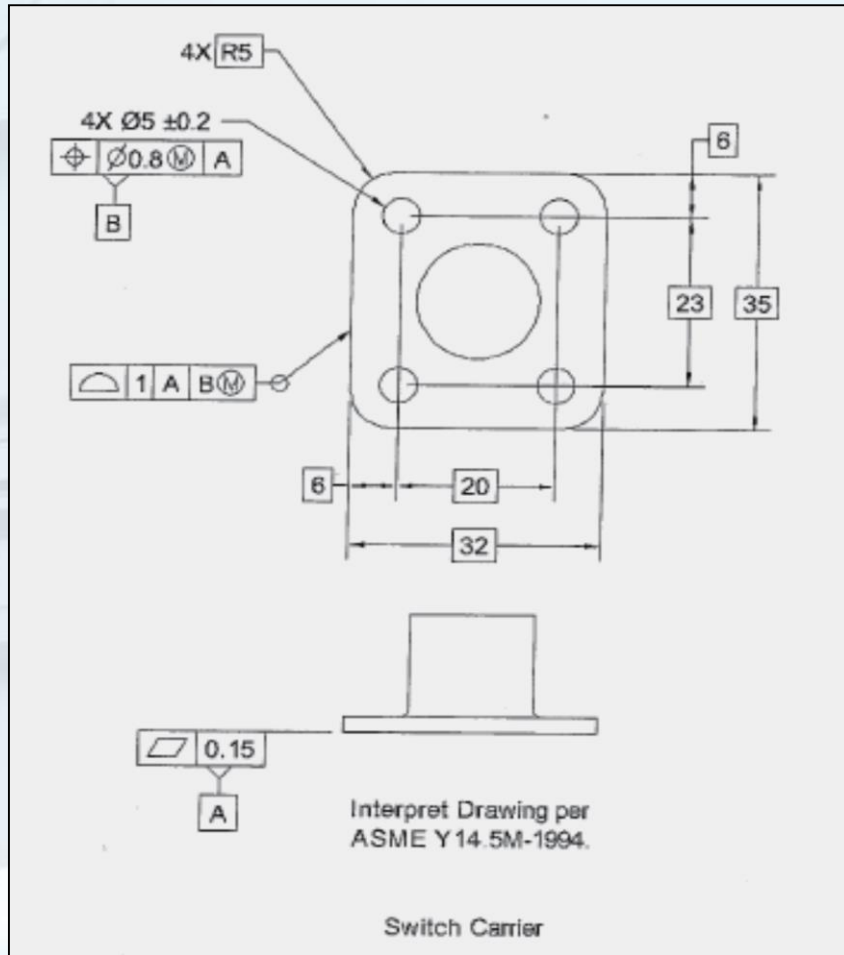

## Simultaneous Requirements

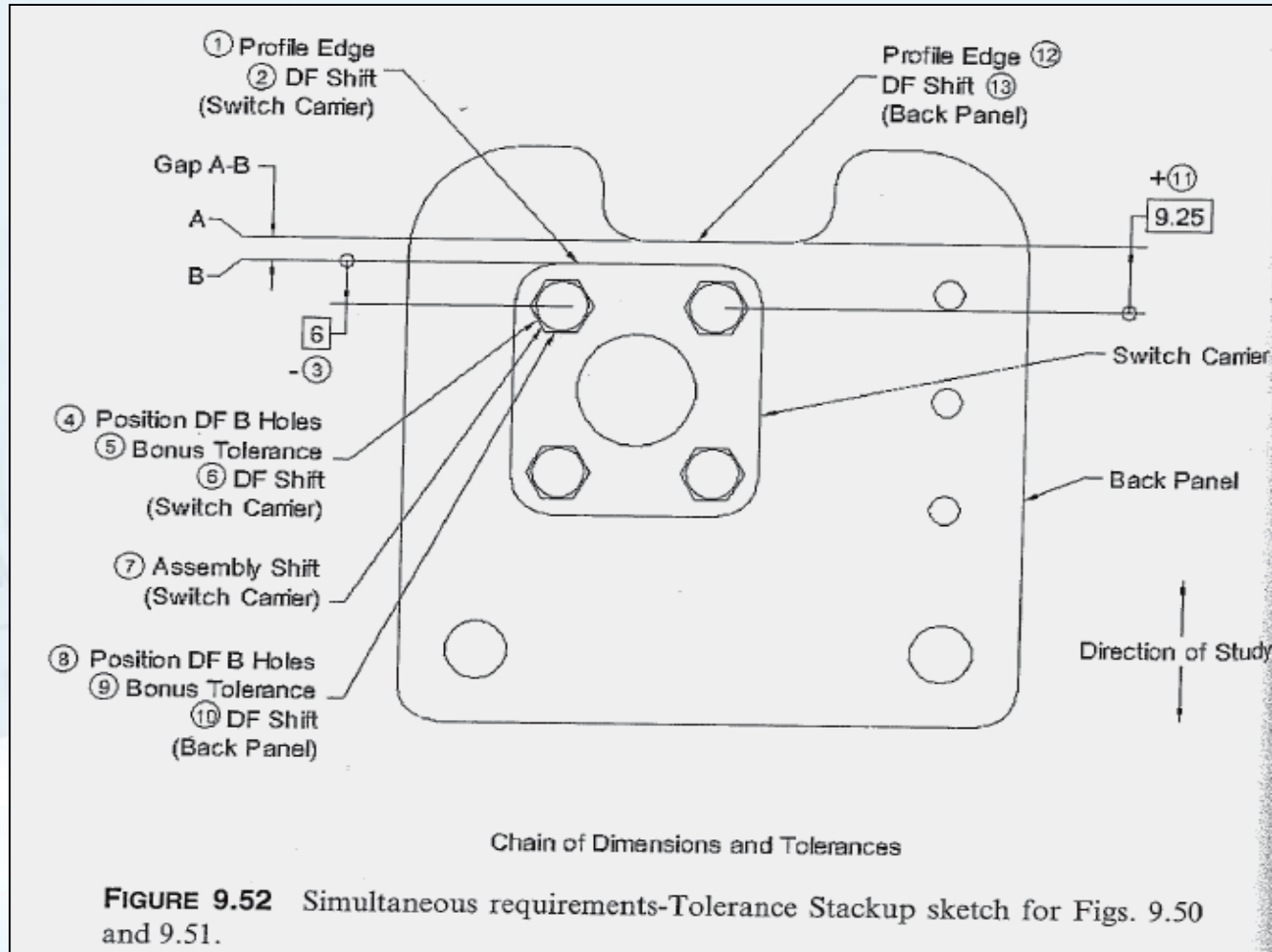



# Chapter #9 Geometric Dimensioning and Tolerancing

## Simultaneous Requirements

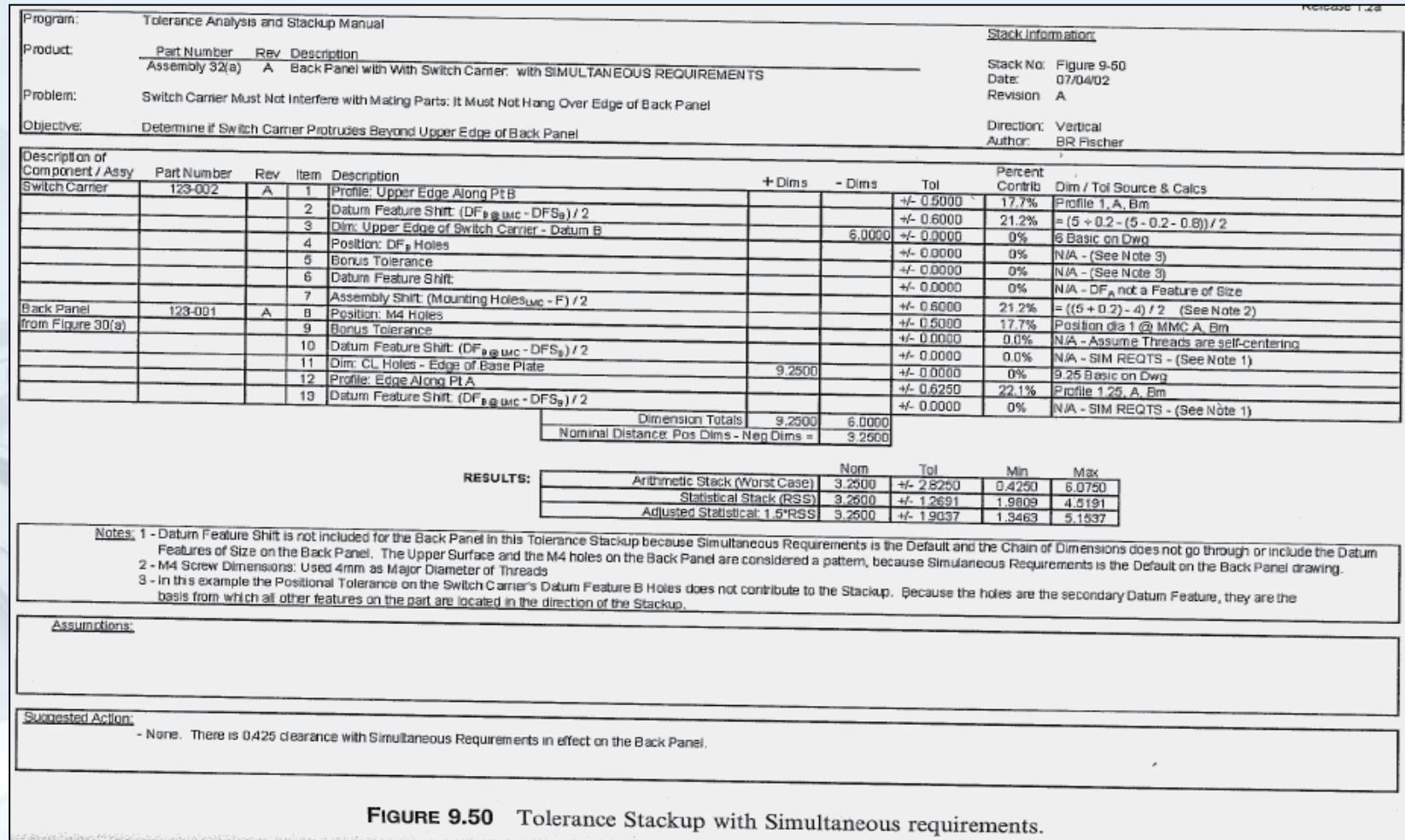

FIGURE 9.50 Tolerance Stackup with Simultaneous requirements.

### Separate Requirements

- During inspection, the relationship between the datum features of size and their simulators may be changed (the part may be shifted about the datum feature simulators) for each feature or group of features related to each feature control frame specifying the same datum reference frame.
- Where specified, separate requirements apply between distinct feature control frames. The relationship of the datum features to their simulators must be maintained while inspecting the features toleranced by any one feature control frame, but may be changed between feature control frames, even if they reference the same datum reference frame.

# Chapter #9 Geometric Dimensioning and Tolerancing

## Separate Requirements

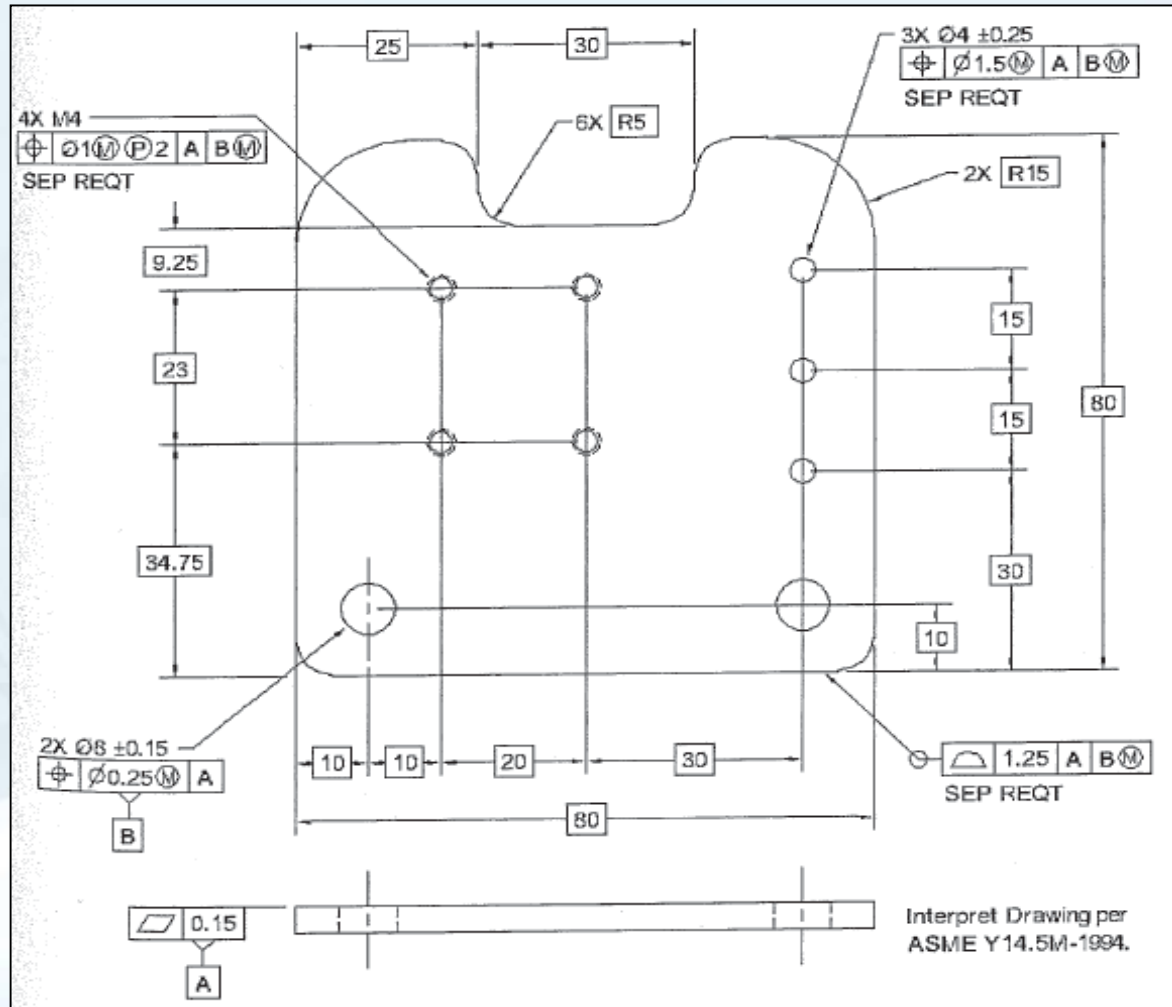

# Chapter #9 Geometric Dimensioning and Tolerancing

## Assembly with Switch Carrier

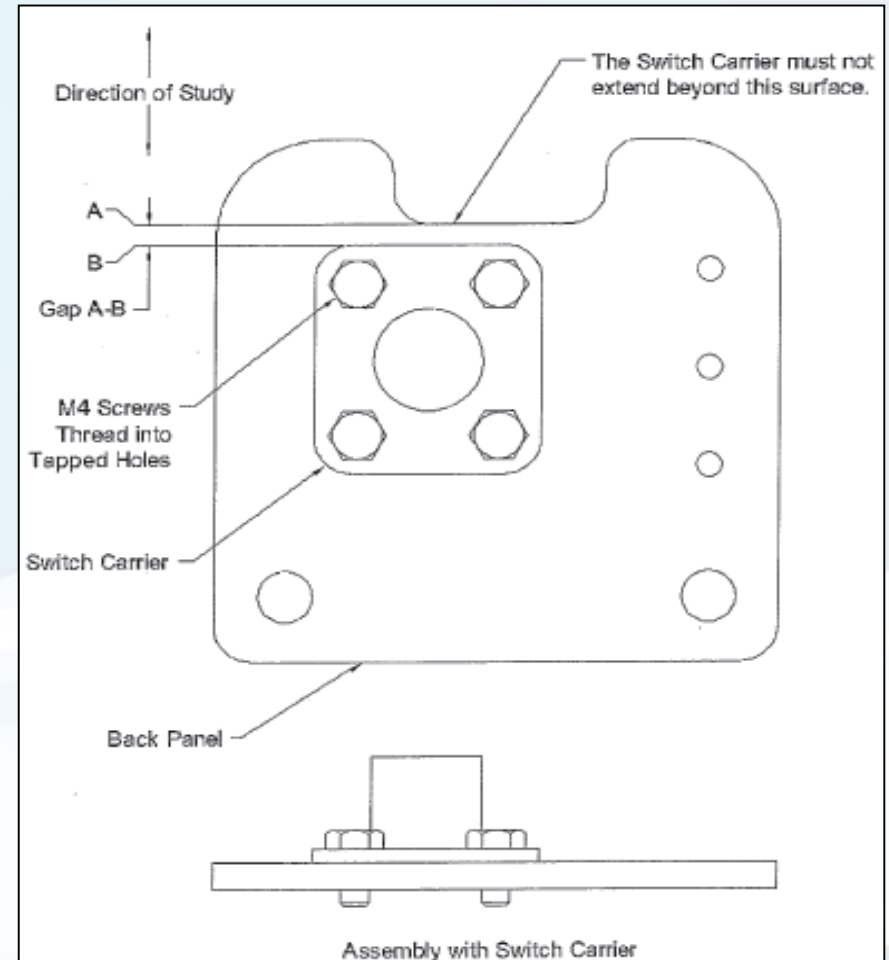
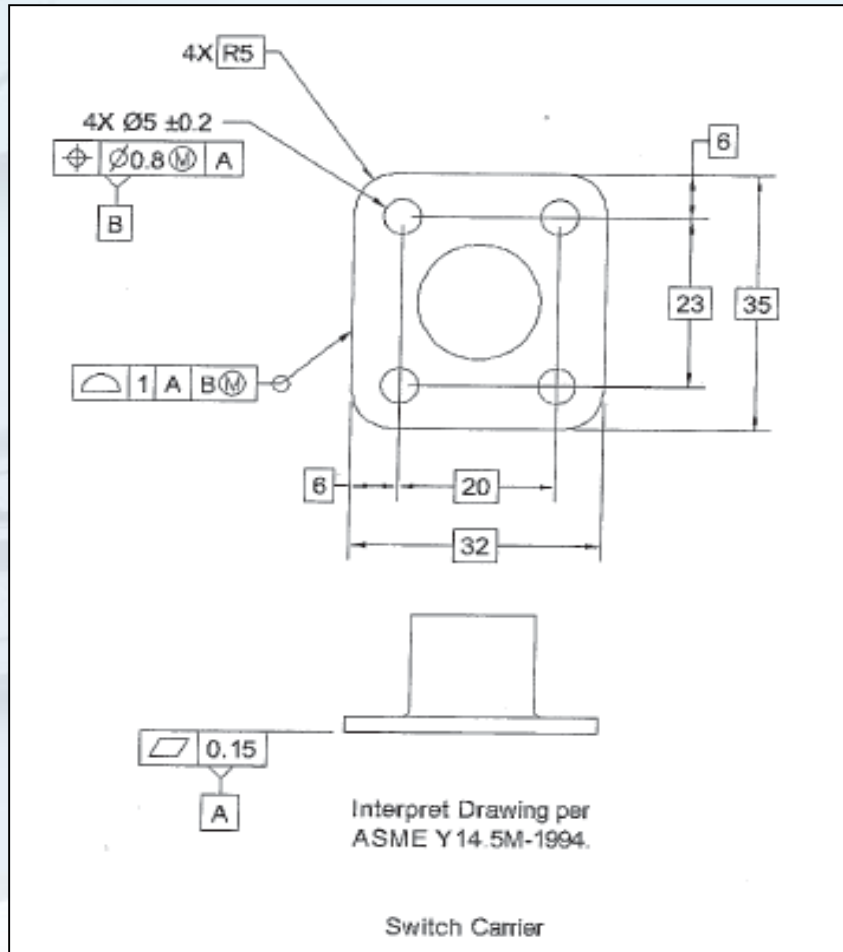

# Chapter #9 Geometric Dimensioning and Tolerancing

## Separate Requirements



FIGURE 9.51 Tolerance Stackup with Separate requirements.



# Chapter #10

QUALITY

## Converting Plus/Minus Tolerancing to Positional Tolerancing and Projected Tolerance Zones





### Plus/Minus Tolerance

- Positional tolerancing is based on the idea that a cylindrical feature of size, such as a hole, should be allowed to vary in location the same amount in any direction.
- Plus/minus location tolerances state how much the location of a feature may vary in a specific direction.

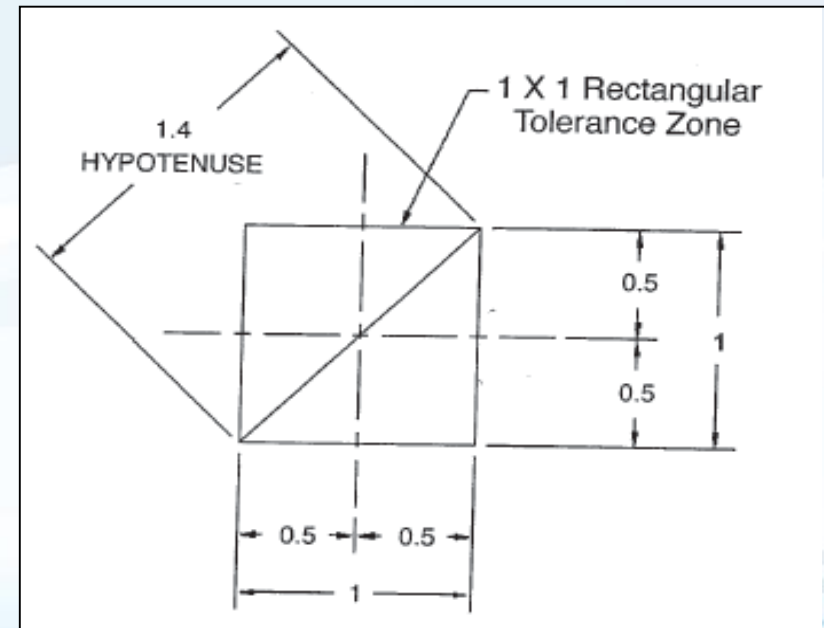
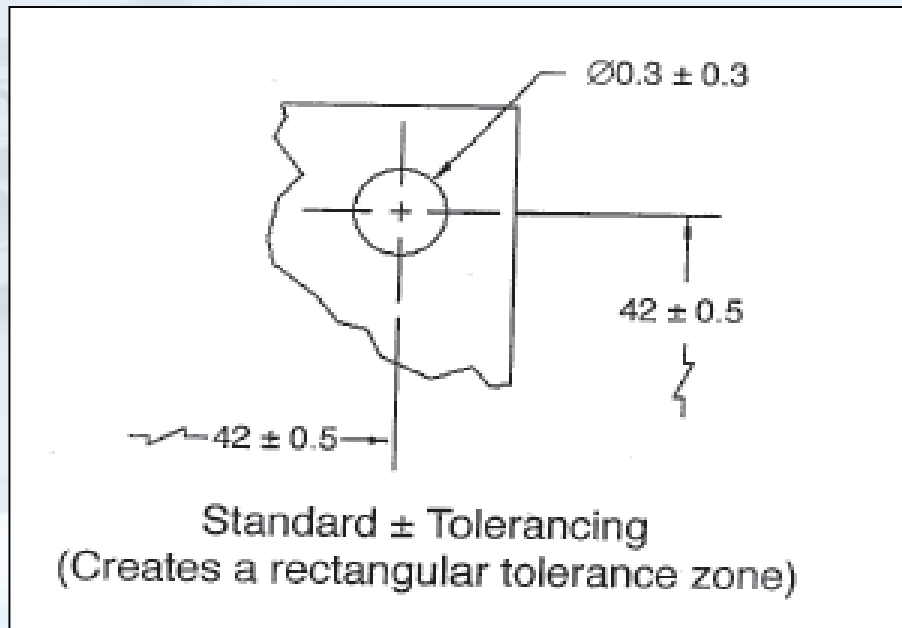

Plus/minus and positional tolerance zones with math.

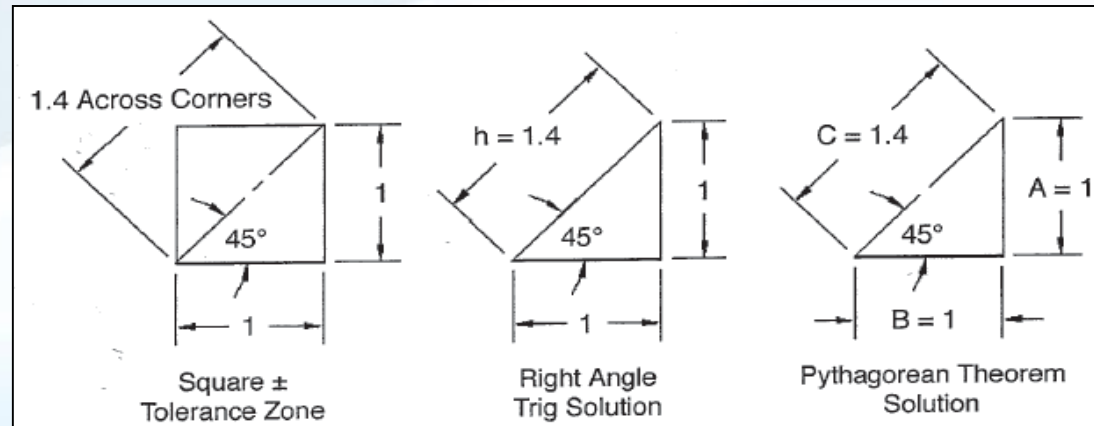
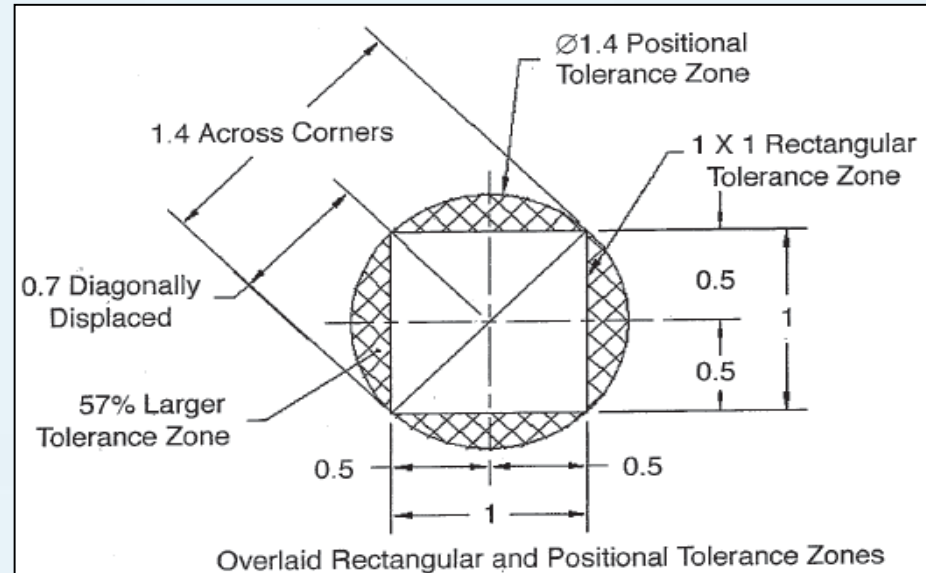

Rectangular  $\pm$  and positional tolerance zones with math.

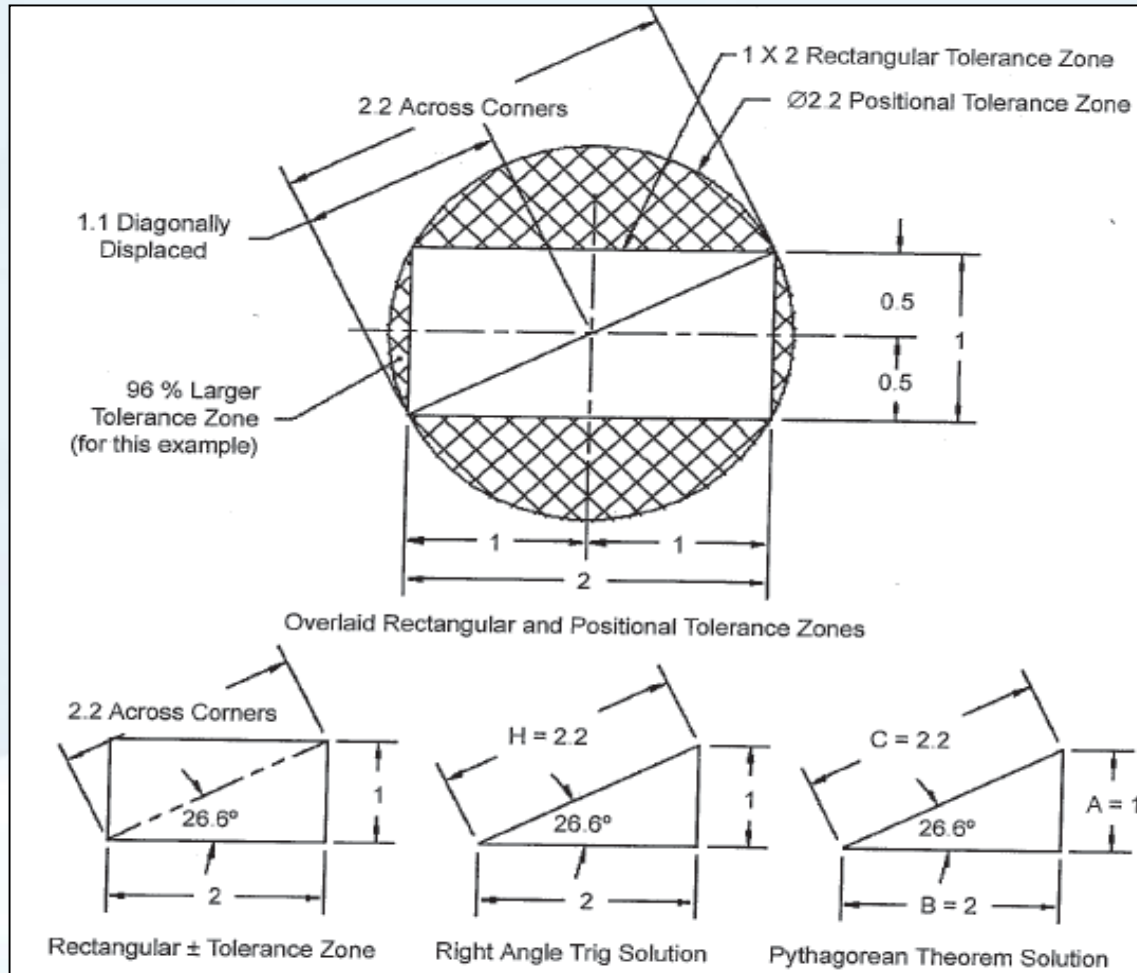

## Projected tolerance zones: Specification and meaning.

**THIS ON THE DRAWING:**

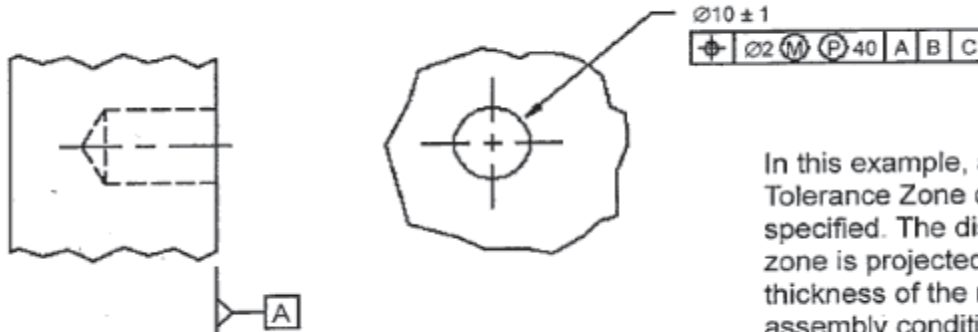

$\text{Ø}10 \pm 1$

$\text{Ø}2 \text{ M } \text{P} 40 \text{ A B C}$

In this example, a Projected Tolerance Zone of 40mm has been specified. The distance the tolerance zone is projected depends on the thickness of the mating parts and assembly conditions.

---

**MEANS THIS:**

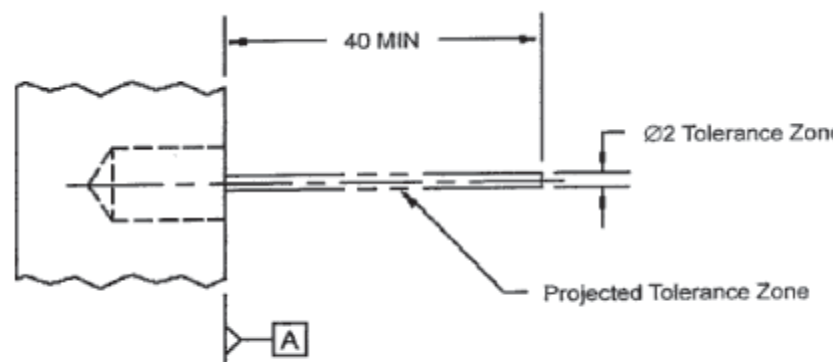

40 MIN

$\text{Ø}2$  Tolerance Zone

Projected Tolerance Zone

A

When a Projected Tolerance Zone is Specified, the tolerance zone lies entirely outside the part. The tolerance zone extends the specified distance from the surface the hole penetrates.

Projected tolerance zones: Specification and meaning.

AND ALLOWS THIS:

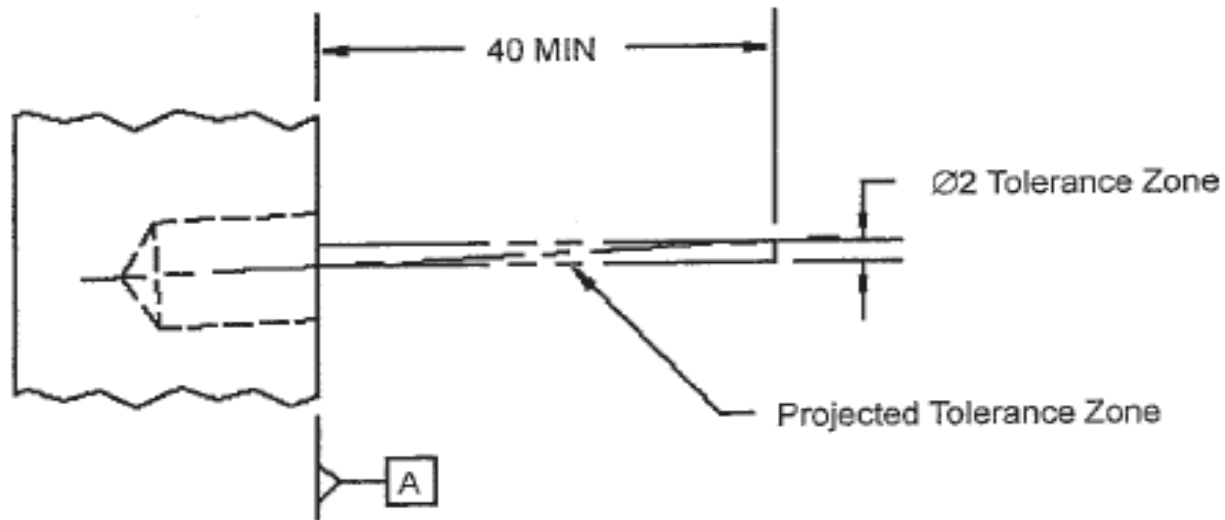

- With a projected tolerance zone specified, the axis of the hole may shift and/or tilt within the projected zone. The axis of the hole is not constrained within the part itself. Notice that in this example the hole falls outside of the zone if the zone was inside the part—this is acceptable, as the axis is only required to be within the projected zone.

Projected tolerance zones: Inside and outside the part.

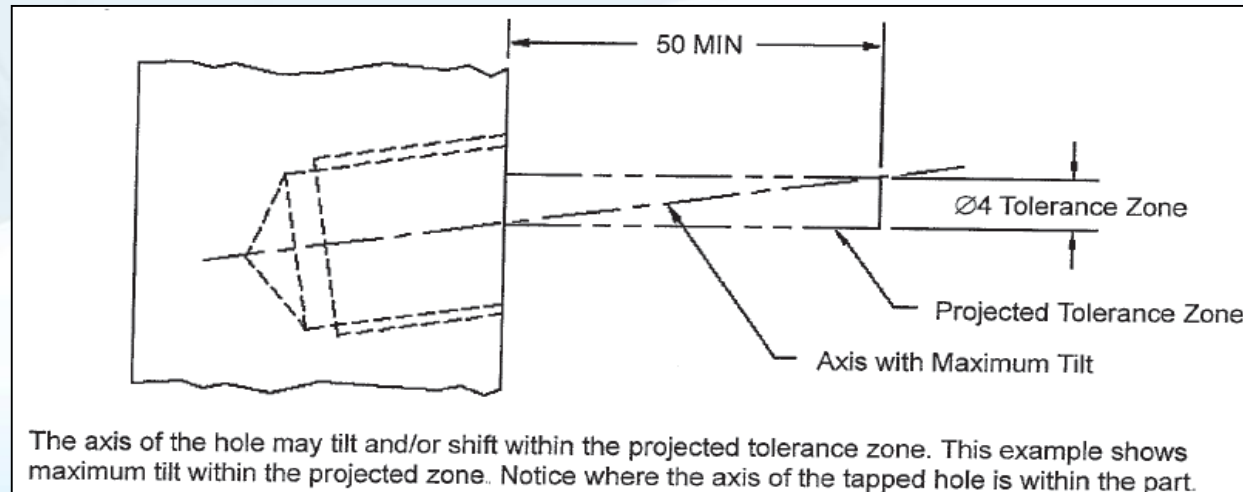
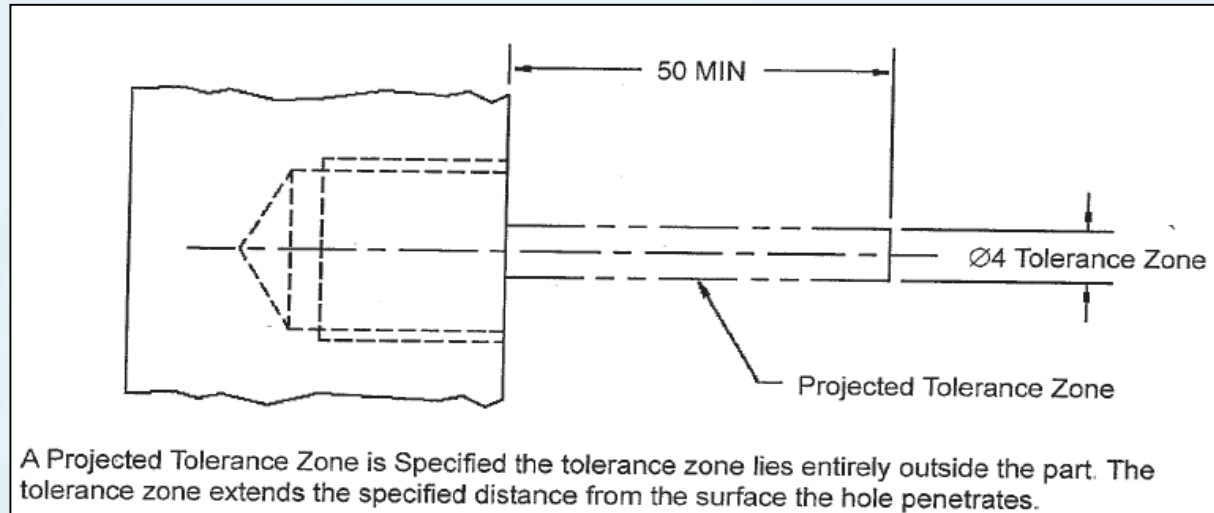



Projected tolerance zones: Inside and outside the part.

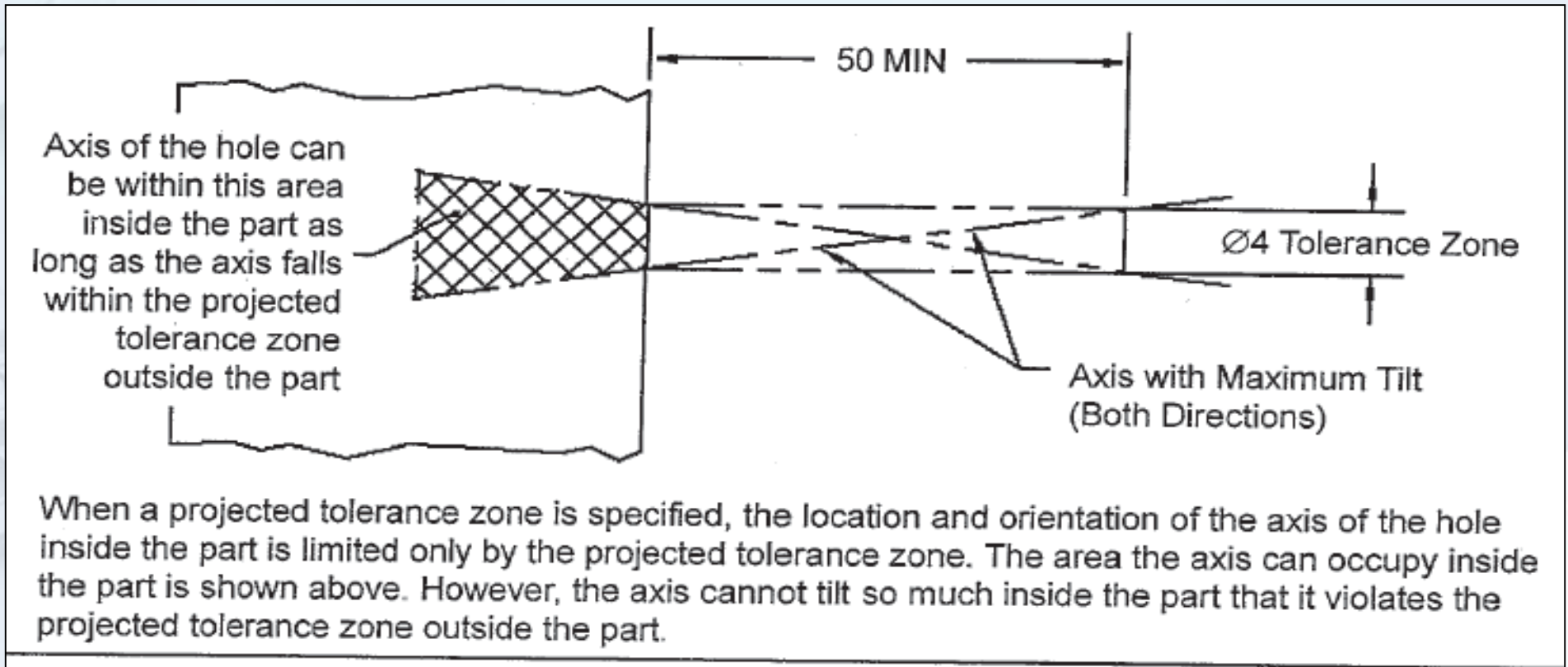

Projected Tolerance Zone is Not Used

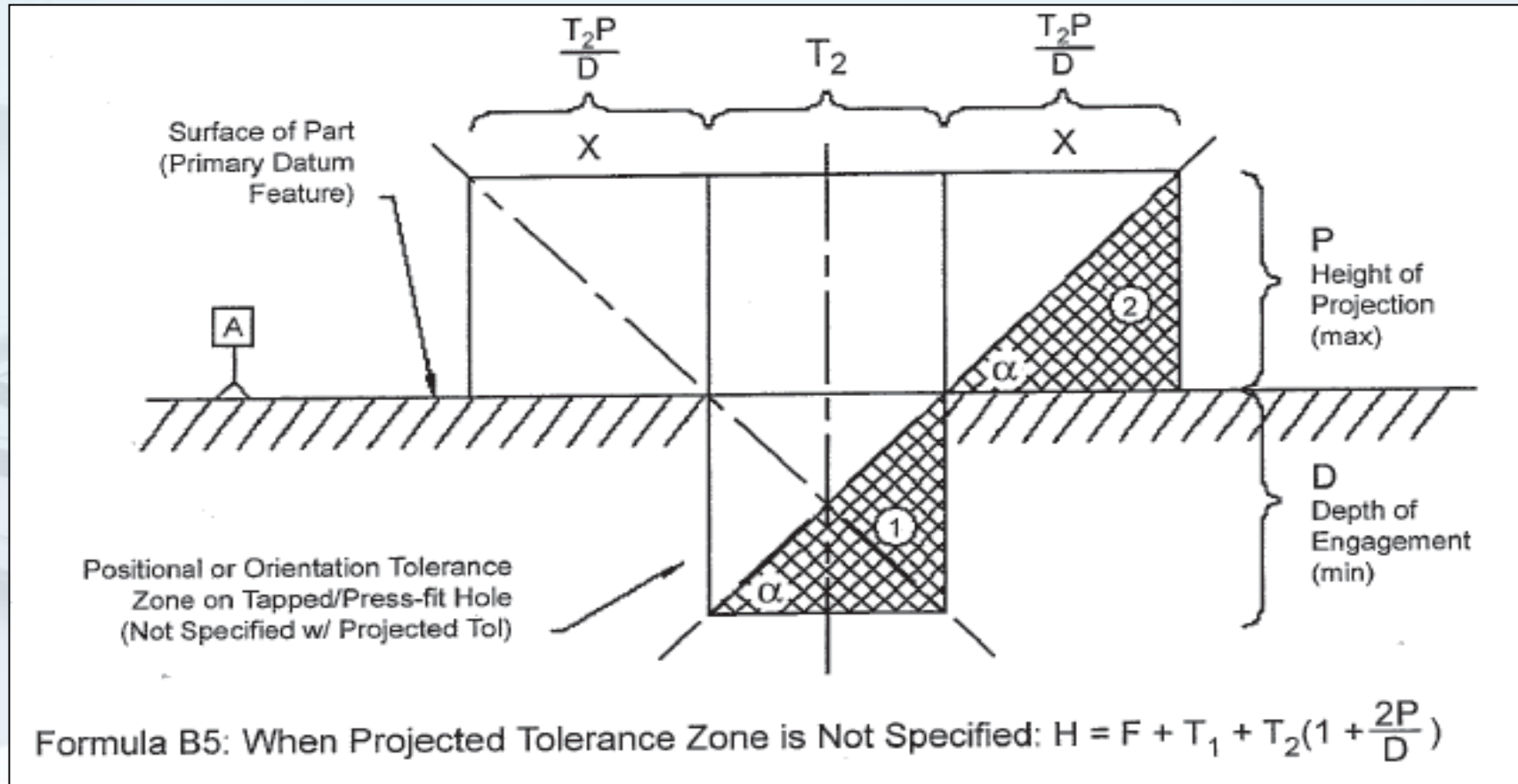

## Projected Tolerance Zone is Not Used

Where:

H = Smallest Clearance Hole Diameter (MMC)

F = Largest Fastener Diameter (MMC)

P = Maximum Projection of Fastener

$T_1$  = Tolerance Zone Diameter for Clearance Hole @ MMC

$T_2$  = Tolerance Zone Diameter for Tapped/Press-fit Hole @ MMC

D = Minimum Depth of Engagement in Threaded or Press-fit Hole

$\alpha$  = Angle of Inclination (Tilt) Allowed by  $T_2$

Proof:

Given the two triangles above representing the tolerance zone diameters:

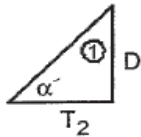

Set up equality based on  $\alpha = \alpha$  (same angle). Prove  $X = \frac{T_2 P}{D}$ :

$$\textcircled{1} \tan \alpha = \frac{D}{T_2}$$

$$\textcircled{2} \tan \alpha = \frac{P}{X}$$

Substitute  $D/T_2$  for  $\tan \alpha$  in Equation  $\textcircled{2}$ :  $\frac{D}{T_2} = \frac{P}{X}$  Solve for X:  $X = \frac{T_2 P}{D}$

As can be seen in the above figure, the Total Projected Tolerance Zone width =  $X + T_2 + X = T_2 + 2X$

(X must be added twice because the axis of the tapped hole may tilt in any direction (left or right in the figure))

Substitute for X in the Total Projected Tolerance Zone Width:  $T_2 + 2X = T_2 + 2 \frac{T_2 P}{D} = T_2 \left(1 + \frac{2P}{D}\right)$

This tolerance zone value can be substituted into the Fixed Fastener Formula  $H = F + T_1 + T_2$  to represent the Equivalent Tolerance Contributed by the Fixed Fastener.

Substitute the equivalent projected tolerance  $T_2 \left(1 + \frac{2P}{D}\right)$  for  $T_2$ :  $H = F + T_1 + T_2 \left(1 + \frac{2P}{D}\right)$

## Perpendicularity is used with Position and a Projected Tolerance Zone is Not Specified

THIS ON THE DRAWING:

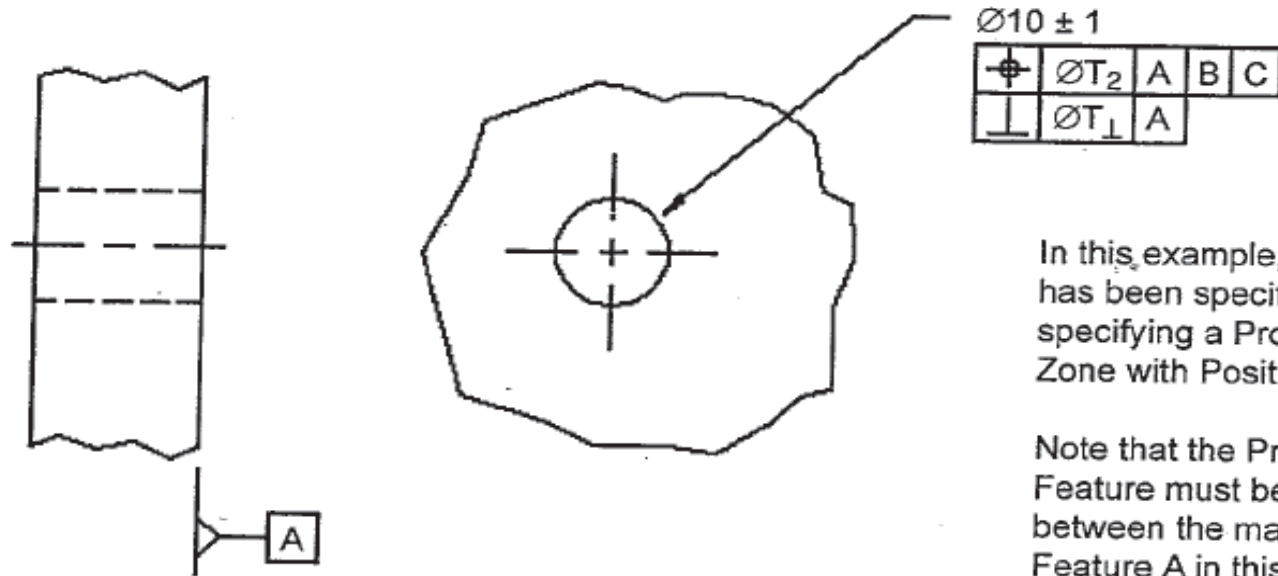

In this example, Perpendicularity has been specified instead of specifying a Projected Tolerance Zone with Position.

Note that the Primary Datum Feature must be the interface between the mating parts, Datum Feature A in this case.

## Perpendicularity is used with Position and a Projected Tolerance Zone is Not Specified

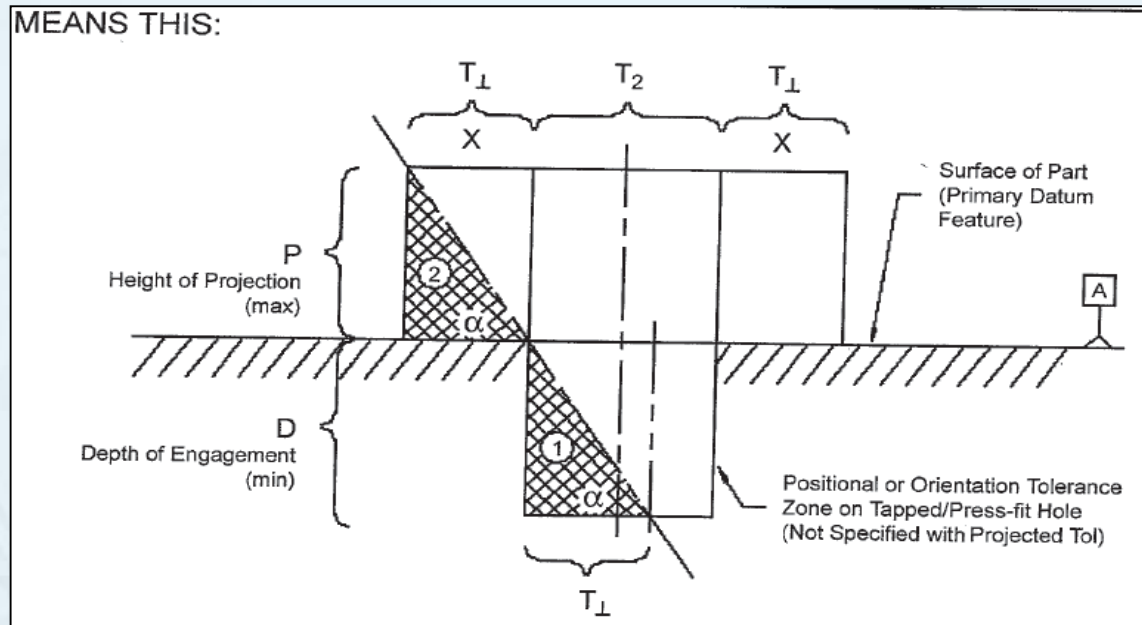

When Perpendicularity is Specified with Position instead of a Projected Tolerance Zone:

Where:

H = Smallest Clearance Hole Diameter (MMC)

F = Largest Fastener Diameter (MMC)

P = Maximum Projection of Fastener

$T_{\perp}$  = Perpendicularity Tolerance

$T_1$  = Tolerance Zone Diameter for Clearance Hole @ MMC

$T_2$  = Tolerance Zone Diameter for Tapped/Press-fit Hole @ MMC

D = Minimum Depth of Engagement in Threaded or Press-fit Hole

$\alpha$  = Angle of Incination (Tilt) allowed by  $T_{\perp}$



# Perpendicularity is used with Position and a Projected Tolerance Zone is Not Specified

Assumptions:

- Primary Datum Feature is the interface between the mating parts.
- $T_2$  and  $T_{\perp}$  applied RFS.  
(Bonus tolerance associated with MMC and LMC present a problem. Not addressed here.)

Solution Requires a Modified Version of Formula B5:  $H = F + T_1 + T_2 + \frac{2T_{\perp}P}{D}$

Per the previous figure, substitute X for the additional tolerance allowed by  $T_{\perp}$ :

$$H = F + T_1 + T_2 + 2X$$

Proof:

Given the two triangles above representing the tolerance zone diameters:

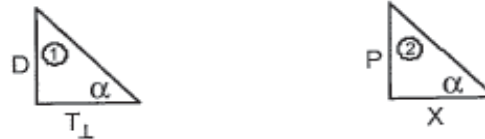

Set up equality based on  $\alpha = \alpha$  (same angle). Prove  $X = \frac{T_{\perp}P}{D}$  :

$$\textcircled{1} \tan \alpha = \frac{D}{T_{\perp}} \quad \textcircled{2} \tan \alpha = \frac{P}{X}$$

Substitute  $\frac{D}{T_{\perp}}$  for  $\tan \alpha$  in Equation  $\textcircled{2}$ :  $\frac{D}{T_{\perp}} = \frac{P}{X}$  Solve for X:  $X = \frac{PT_{\perp}}{D}$

Substitute for X in modified formula B5 above:  $H = F + T_1 + T_2 + 2X$

$$H = F + T_1 + T_2 + \frac{2PT_{\perp}}{D}$$



# Chapter #11

QUALITY

## Diametral Tolerancing Stack-up



## Coaxial Error and Positional Tolerancing

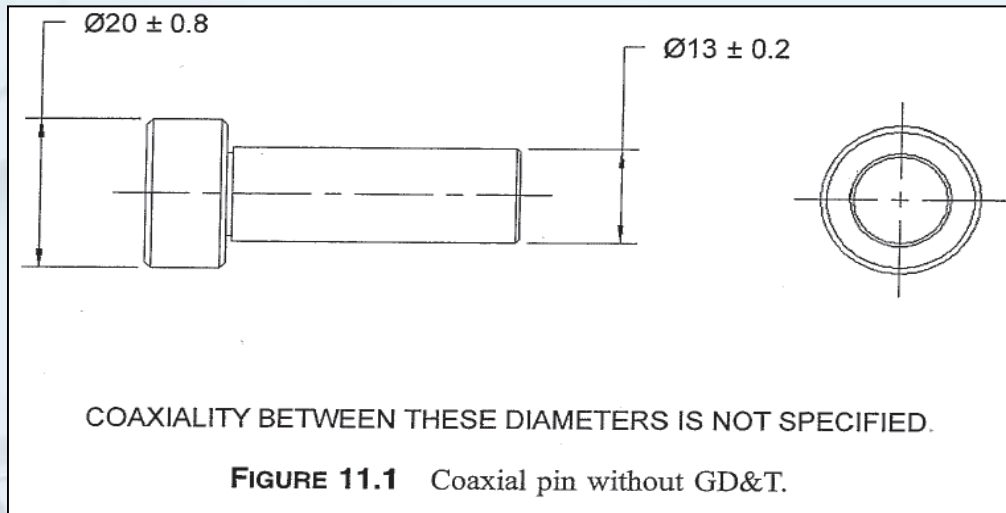

to calculate the maximum coaxial error or eccentricity between nominally coaxial features.

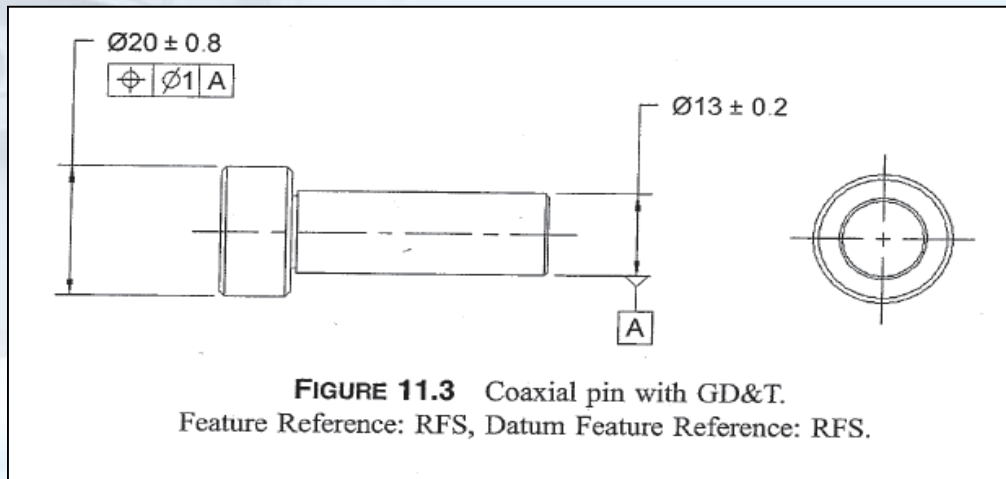

Coaxial Error and Positional Tolerancing RFS/Datum RFS

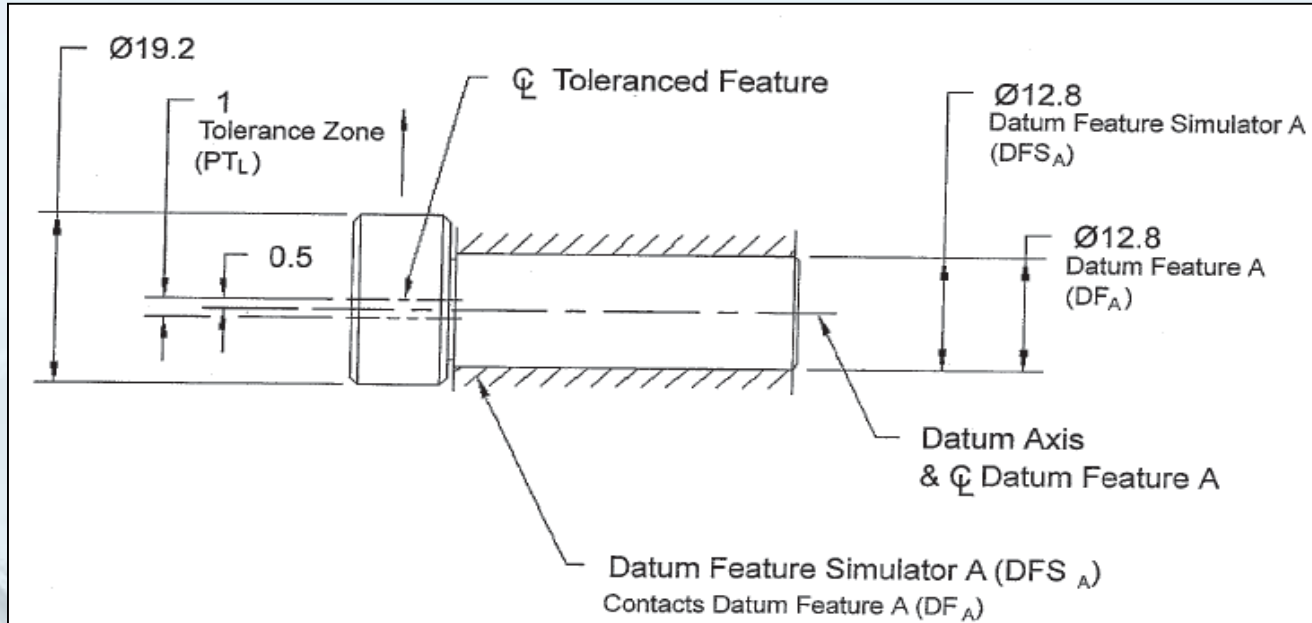
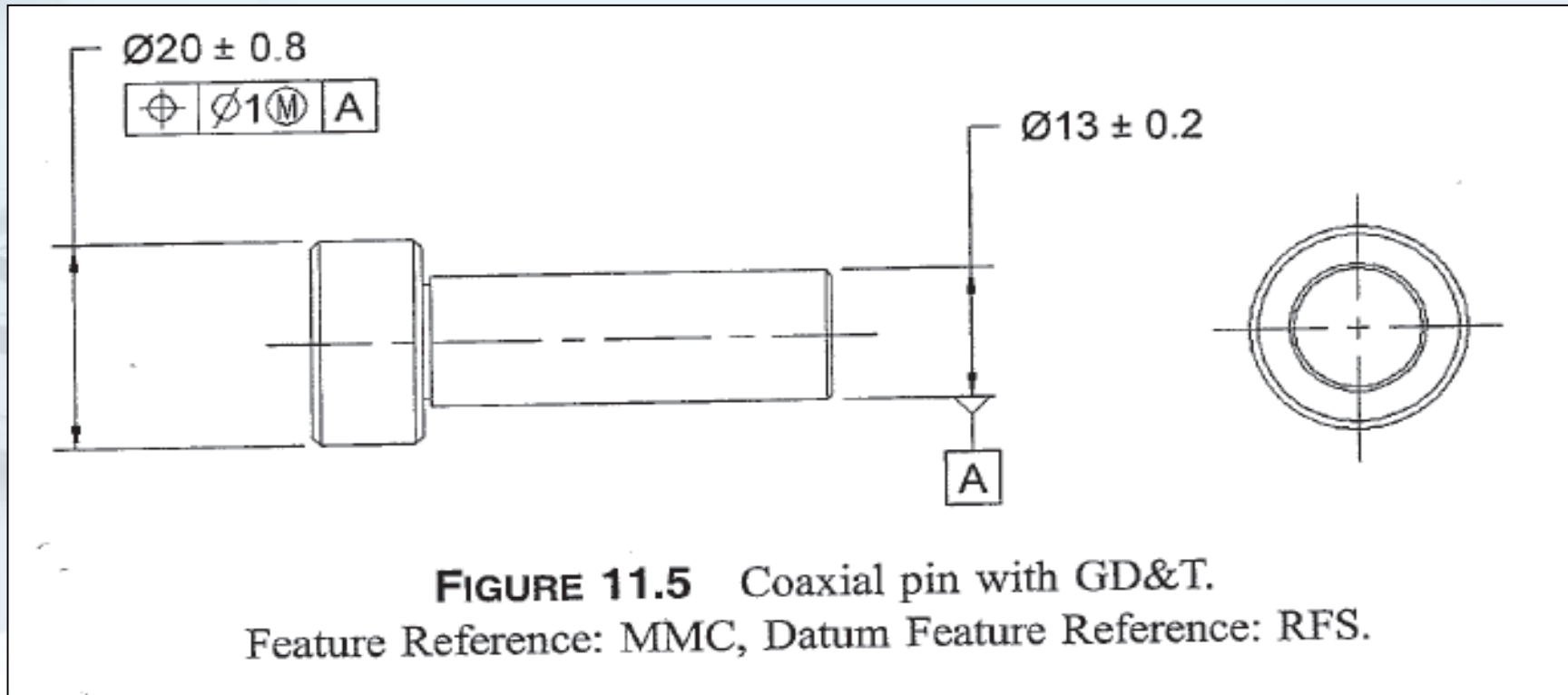

FIGURE 11.4 Maximum coaxial error for Pin in Figure 12.3.

$$\begin{aligned} \text{Max coaxial error} &= \frac{DFS_A - DF_A + PTL}{2} = \frac{12.8 - 12.8 + 1}{2} \\ &= \frac{1}{2} = 0.5 \end{aligned}$$

Coaxial Error and Positional Tolerancing MMC/Datum RFS

To calculate the maximum coaxial error or eccentricity between nominally coaxial features.



## Coaxial Error and Positional Tolerancing MMC/Datum RFS

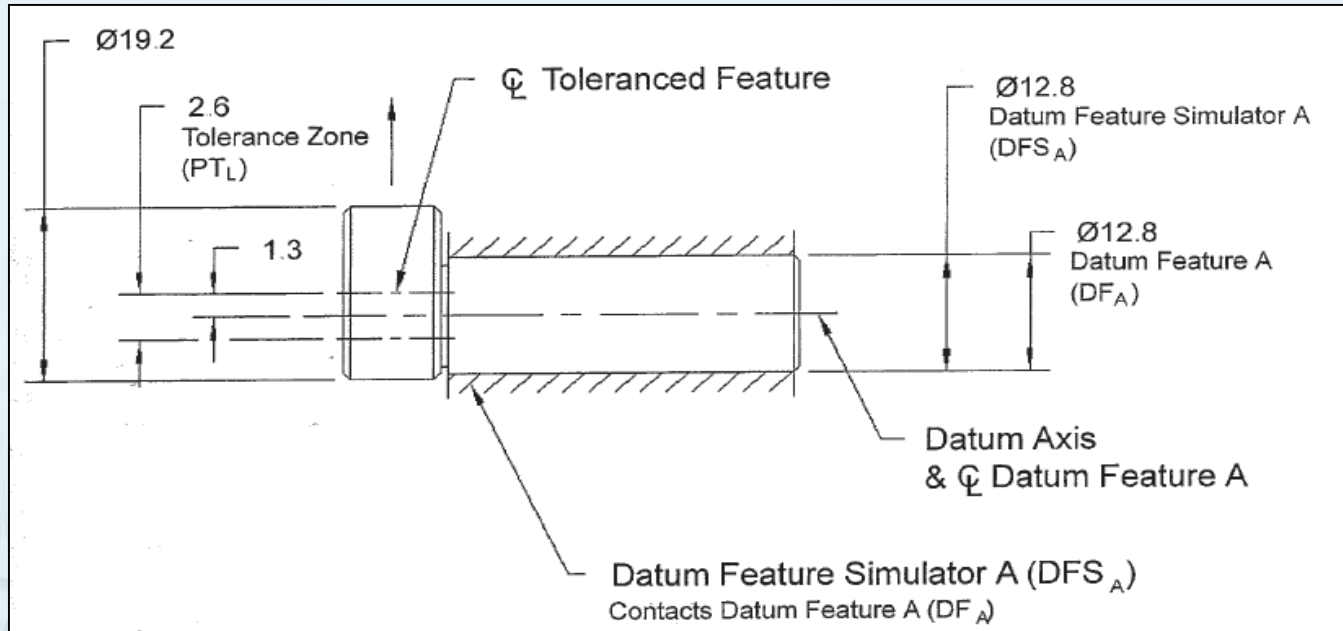
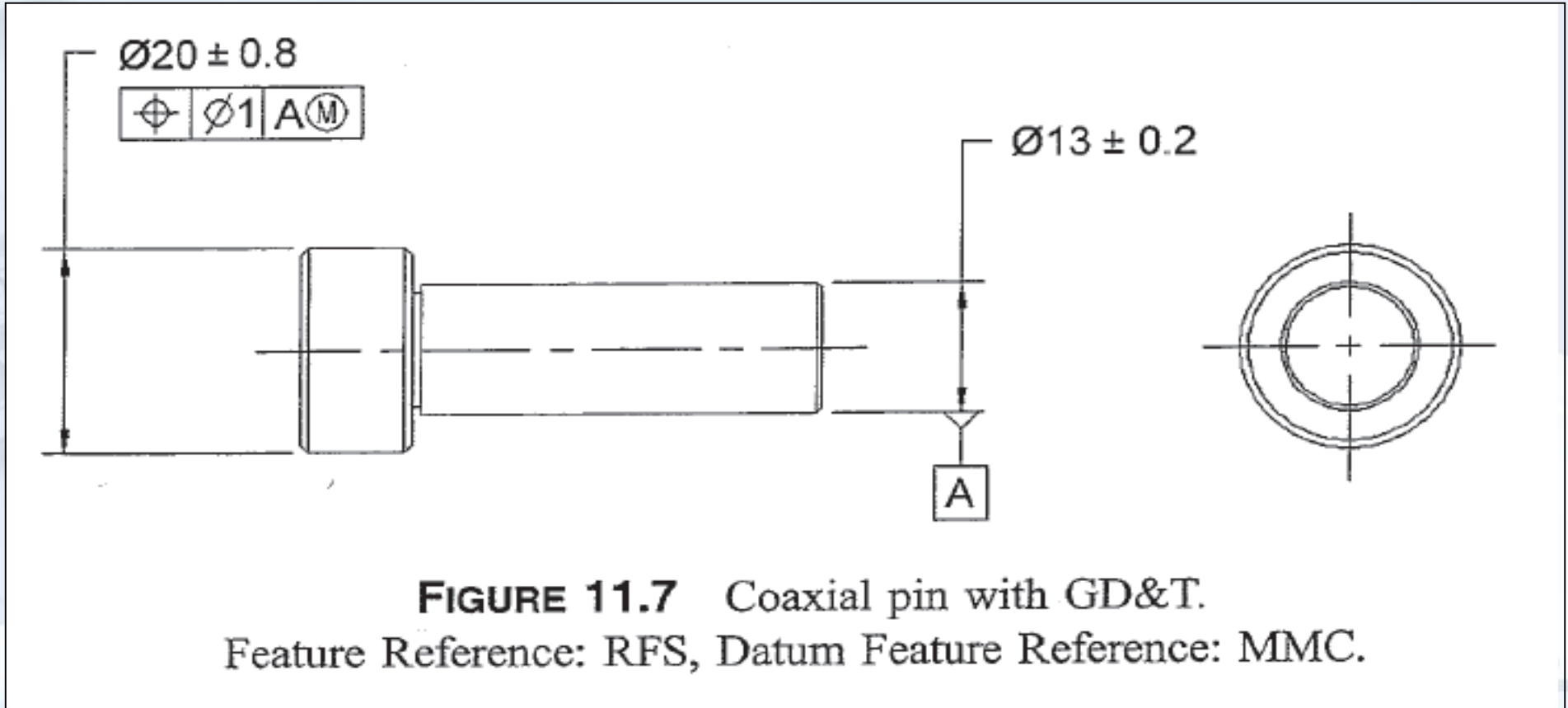

**FIGURE 11.6** Maximum coaxial error for Pin in Figure 12.5: MMC-RFS.

$$\begin{aligned} \text{Max coaxial error} &= \frac{DFS_A - DF_A + PTL}{2} = \frac{12.8 - 12.8 + 2.6}{2} \\ &= \frac{2.6}{2} = 1.3 \end{aligned}$$

Coaxial Error and Positional Tolerancing RFS/Datum MMC

To calculate the maximum coaxial error or eccentricity between nominally coaxial features.





Coaxial Error and Positional Tolerancing RFS/Datum MMC

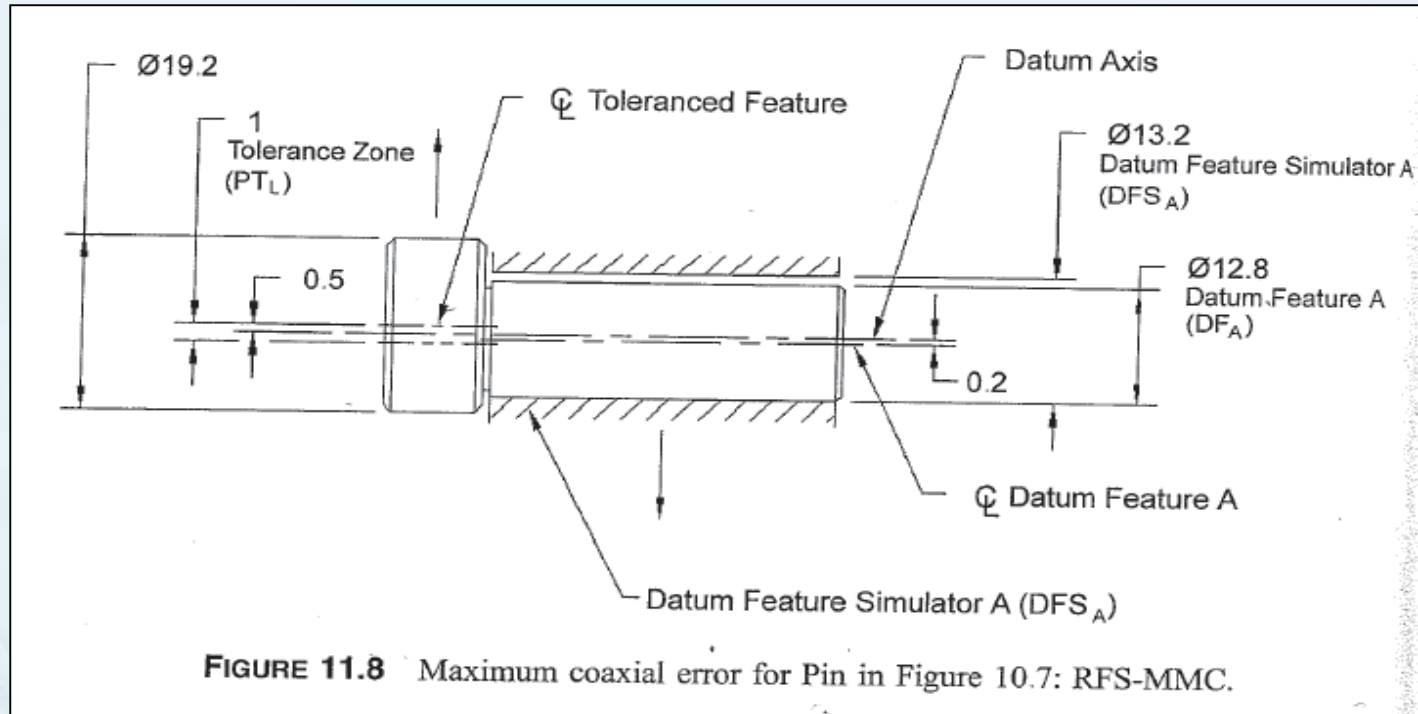
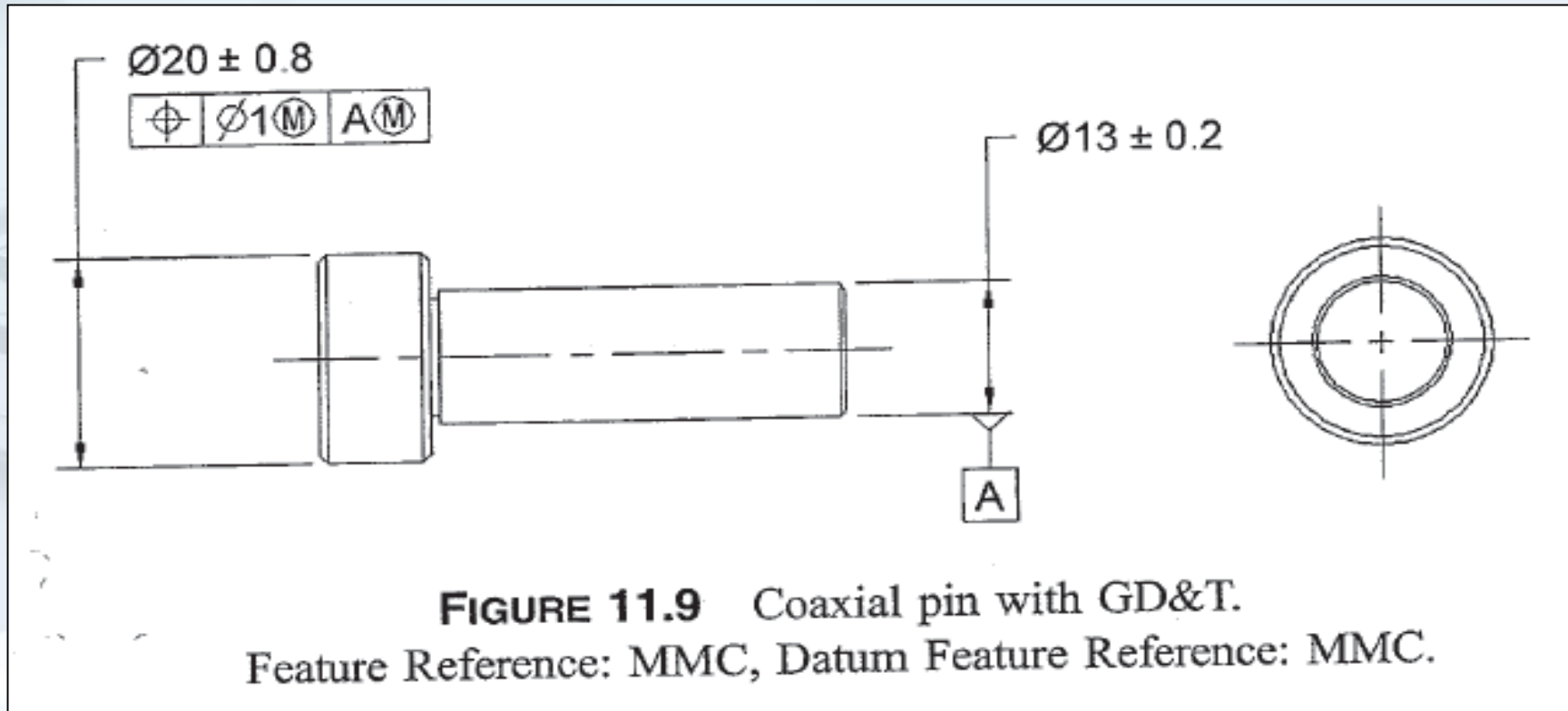

FIGURE 11.8 Maximum coaxial error for Pin in Figure 10.7: RFS-MMC.

$$\begin{aligned} \text{Max coaxial error} &= \frac{DFS_A - DF_A + PTL}{2} = \frac{13.2 - 12.8 + 1}{2} \\ &= \frac{1.4}{2} = 0.7 \end{aligned}$$

Coaxial Error and Positional Tolerancing MMC/Datum MMC

To calculate the maximum coaxial error or eccentricity between nominally coaxial features.



Coaxial Error and Positional Tolerancing MMC/Datum MMC

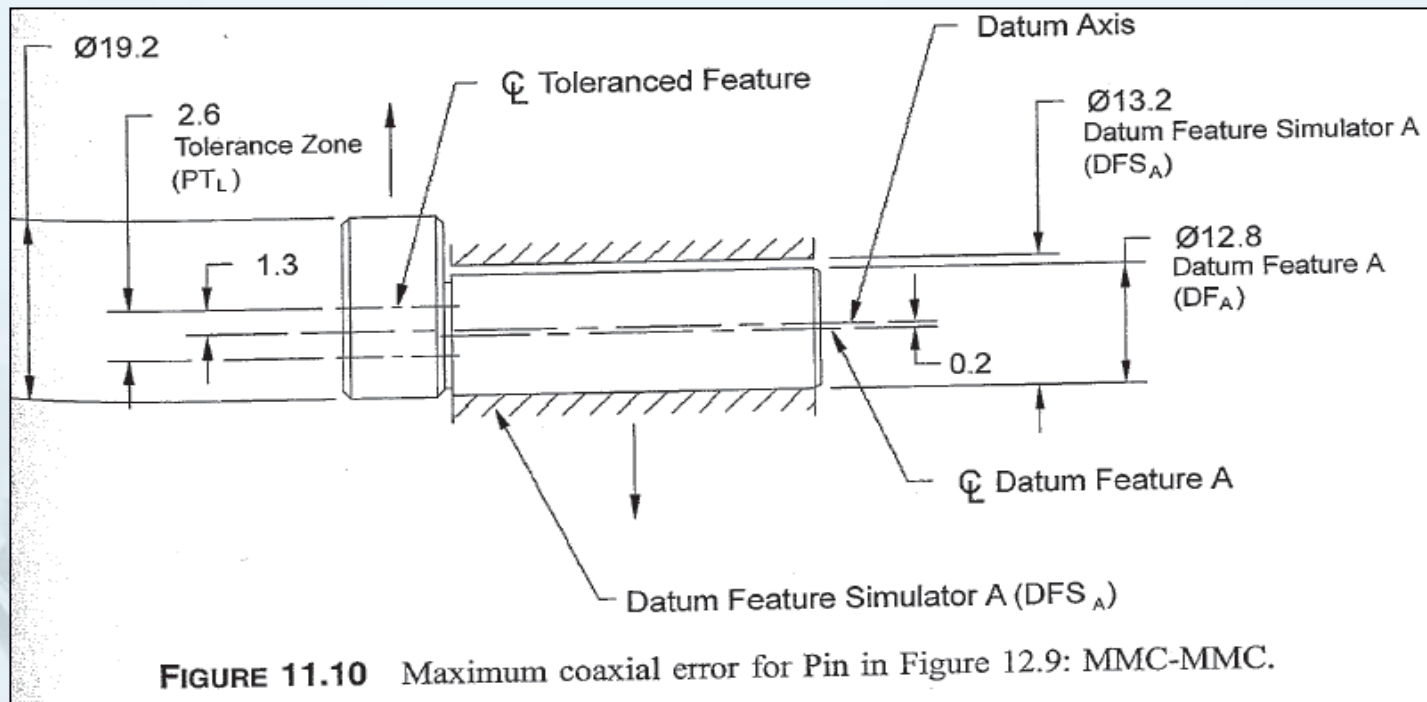

FIGURE 11.10 Maximum coaxial error for Pin in Figure 12.9: MMC-MMC.

$$\begin{aligned} \text{Max coaxial error} &= \frac{DFS_A - DF_A + PT_L}{2} = \frac{13.2 - 12.8 + 2.6}{2} \\ &= \frac{3}{2} = 1.5 \text{ (Worst-case!)} \end{aligned}$$

# Chapter #12

QUALITY

## MMC/LMC Tolerancing Analysis



### Material Condition Modifiers

- Selecting a material condition modifier is not an arbitrary decision—it is a functional decision. Other factors may influence the decision, such as fixturing, inspection practices, or company preference, but first and foremost it is a functional decision.
- When performing a Tolerance Stack up, the Tolerance Analyst breaks out the amount of variation contributed by each tolerance and each material condition modifier onto separate lines in the Tolerance Stack up report.

Ⓜ	MAXIMUM MATERIAL CONDITION
Ⓛ	LEAST MATERIAL CONDITION
Ⓢ	REGARDLESS OF FEATURE SIZE

**FIGURE 12.1** Material condition modifiers. The symbol for RFS is obsolete, but may be reinvoked from ANSI Y14.5M-1982-see ASME Y14.5M-1994 para. 2.8(b.)

### Material Condition Modifiers Selection criteria

- Three factors must be considered when selecting a material condition modifier:
  1. fit : MMC
  2. edge distance or wall thickness: LMC
  3. alignment: RFS
- If fit is the only functional concern, then MMC is the correct material condition modifier to use.



### Material Condition Modifiers Selection criteria

- Maintaining Minimum Wall Thickness or Edge Distance  
(When at Least One of the Features Is an Internal Feature)
- If the only functional concern is that minimum wall thickness or edge distance is maintained at the worst-case condition, then LMC is the correct material condition modifier to use.
- In many situations, the axes of features must be as close to their nominal location as possible.
- Where alignment is the only functional concern, such as where the axes of two or more diameters must be aligned, RFS is the material condition modifier to use.

# Chapter #13

QUALITY

## Tolerance Stack-up Sketch



### What needed to create Tolerance Stackup Sketch

- Creating the Tolerance Stack up sketch should be the first step when starting a Tolerance Stack up. The sketch should always be done prior to filling out the Tolerance Stack up report form.
- **Three things are needed to create the Tolerance Stack up sketch:**
  - Detail drawings of all the manufactured components in the Tolerance Stack up
  - Detail sheets and related dimension and tolerance information for catalog items
  - An assembly drawing, and possibly a model of the assembly or the actual assembly.

Tolerance Stack up Sketch Content

Part and Assembly Geometry in the Tolerance Stack up Sketch

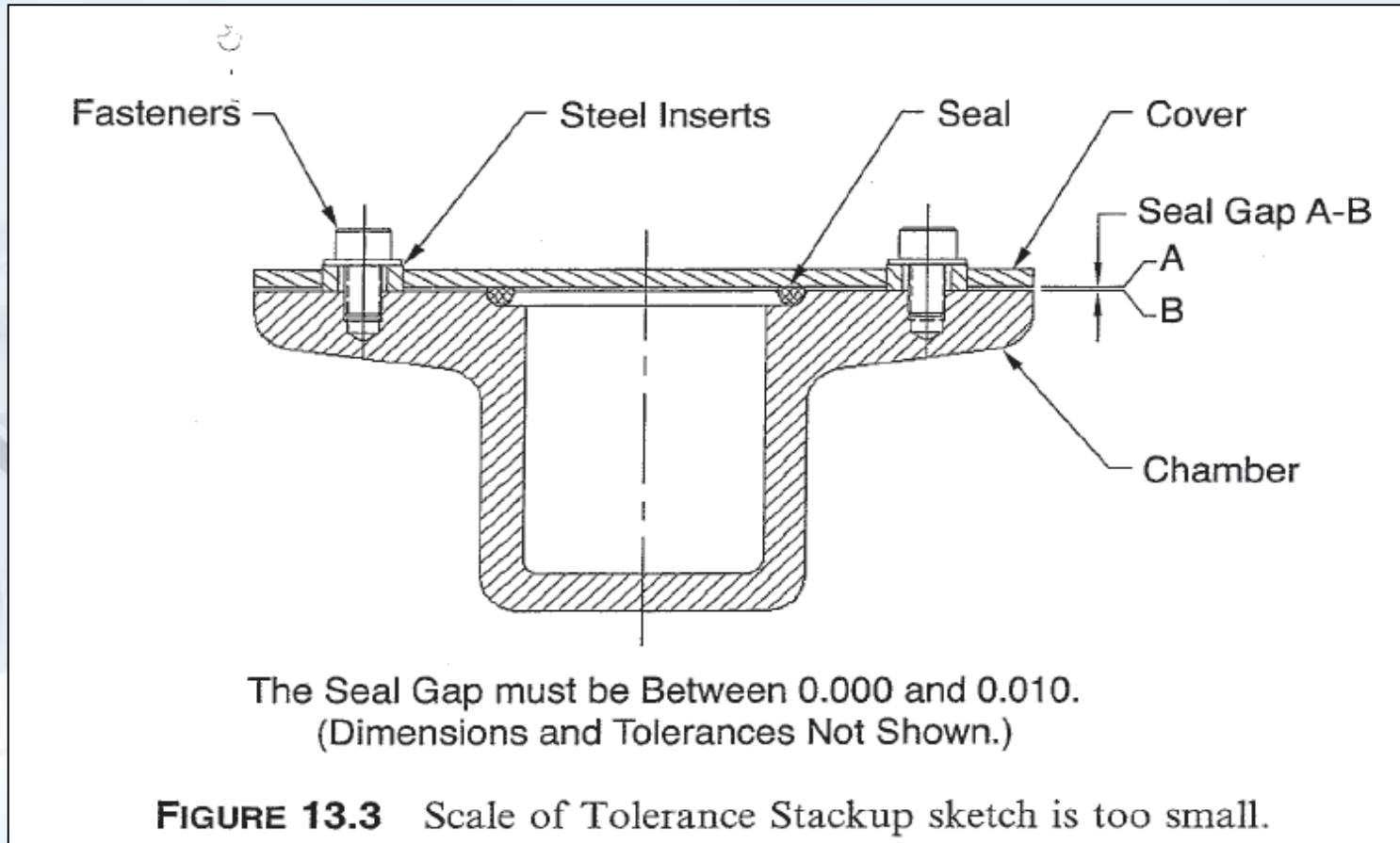

## Part and Assembly Geometry in the Tolerance Stack up Sketch

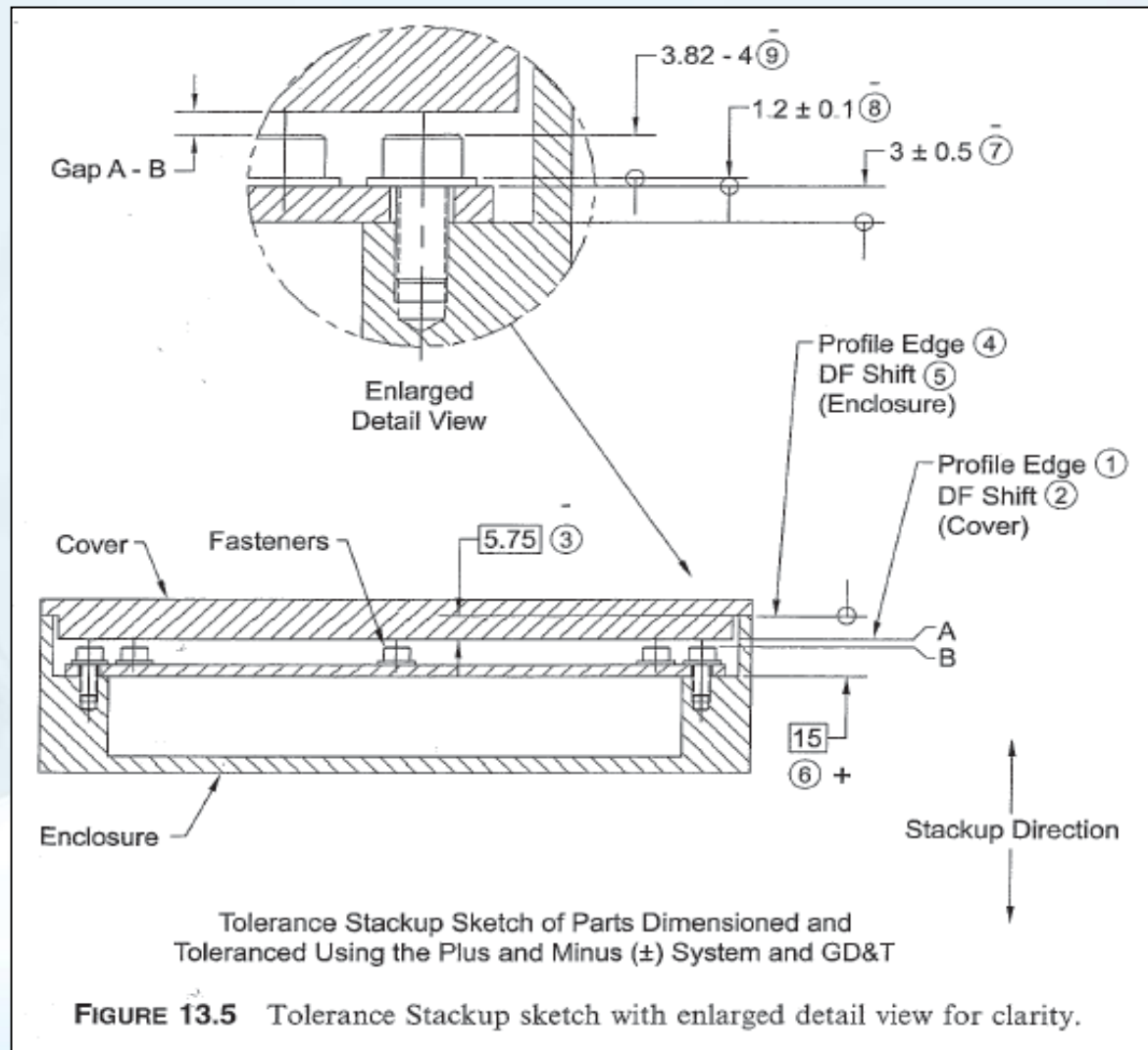

### Tolerance Stack up Sketch Annotation

**Tolerance Stack up sketch annotation may include:**

1. part identification
2. identification of the distance or gap being studied
3. identification of the Tolerance Stack up direction
4.  $\pm$  Dimensions and Tolerances
5. converted angular Dimensions and Tolerances
6. geometric Dimensions and Tolerances
7. bonus tolerances
8. datum feature shift
9. assembly shift
10. item numbers
11. dimension direction signs (positive or negative direction)
12. title
13. reference information



Tolerance Stack up Sketch Annotation

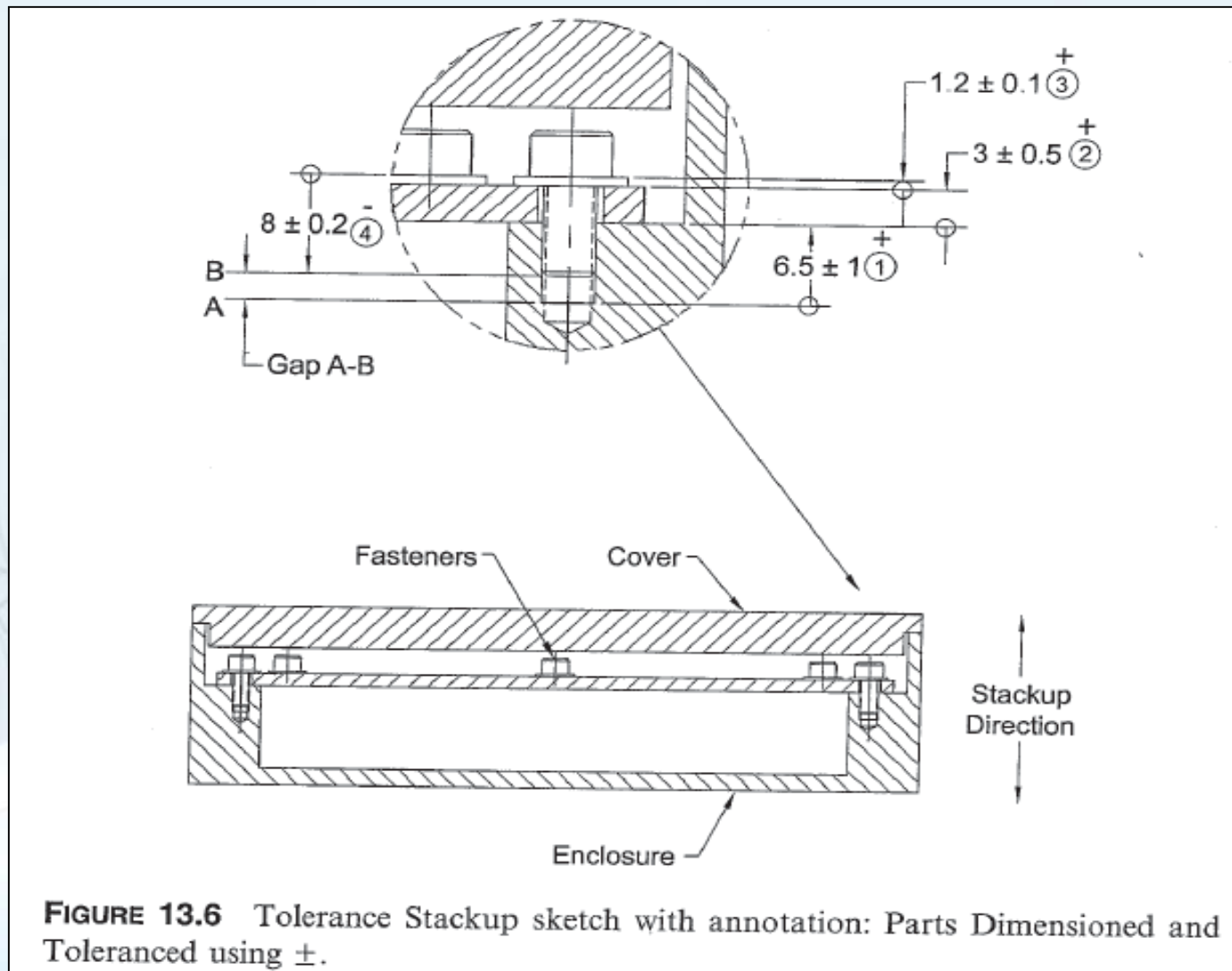

Tolerance Stack up Sketch Annotation

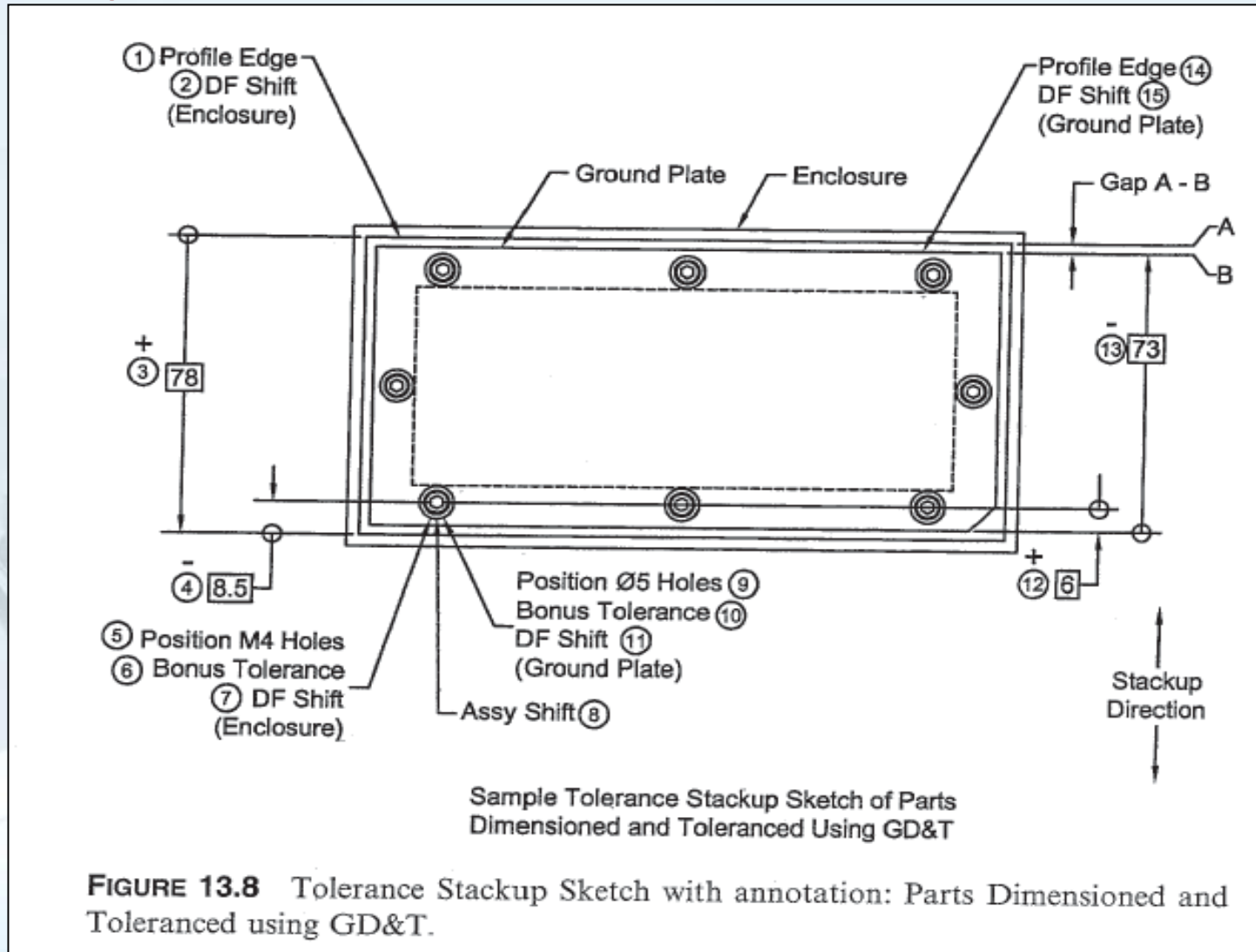

### Tolerance Stack up Sketch Annotation

Steps for Creating a Tolerance Stack up Sketch on Parts and Assemblies Dimensioned and Toleranced Using GD&T:

1. Part identification
2. Distance or gap being studied
3. Direction of the Tolerance Stack up
4. The chain of Dimensions and Tolerances
5. Add a descriptive title to the Tolerance Stack up sketch.
6. Add any reference information that may be helpful to the reader.

# Chapter #14

QUALITY

## Tolerance Stack-up Report



# Chapter #14 Tolerance Stack-up Report

## Tolerance Stack up Report Form

Release 1.2a

Program: \_\_\_\_\_

Product: Part Number Rev Description Stack Information

Problem: **1 - Tracking and Title Data Block** Stack No:  
Date:  
Revision:

Objective: \_\_\_\_\_ Direction:  
Author:

Description of Component / Assy	Part Number	Rev	Item	Description	+ Dims	- Dims	Tol	Percent Contrib	Dim / Tol Source & Calcs
			1				±		
			2				±		
			3				±		
			4				±		
			5				±		
			6				±		
			7				±		
			8				±		
			9				±		
			10				±		
			11				±		
			12				±		
			13				±		
<b>2 - Data Entry Block</b>									
Dimension Totals									
Nominal Distance: Pos Dims - Neg Dims =									

RESULTS: 

Arithmetic Stack (Worst Case)	Nom	Tot	Min	Max
Statistical Stack (RSS)				
Adjusted Statistical 1.5*RSS				

**3 - Results Block**

Notes:

**4 - Notes Block**

Assumptions:

**5 - Assumptions Block**

Suggested Action:

**6 - Suggested Action Block**

FIGURE 14.1 Sample Tolerance Stackup report format with blocks identified.

### Dimension And Tolerance Entry

- **Guidelines for entering plus minus dimensions and tolerances**

The equal bilateral equivalent Dimension and Tolerance values are entered into the Tolerance Stack up report as follows:

Positive or negative direction signs are assigned to each dimension in the Tolerance Stack up.



### Dimension And Tolerance Entry – Basic Dimension

- Basic dimension values are entered into the Tolerance Stack up report form on a separate line from the geometric tolerances.
- geometric dimensions and tolerances are specified as unequal bilateral or unilateral, they must be converted to equal bilateral format before they can be entered into the Tolerance Stack up report form.

### Dimension And Tolerance Entry – GD & T

- dimension value and geometric tolerance information are entered on separate lines in the Tolerance Stack up report form.
- material condition modifiers can be applied to some geometric tolerances, allowing the tolerance zone to increase in size, leading to bonus tolerance.
- Datum feature references may be modified by material condition modifiers, creating the possibility of datum feature shift.

### Dimension And Tolerance Entry – GD & T

- The geometric tolerance should be entered on a single line in the Tolerance Stack up report form.
- Bonus tolerance should be entered on the next line beneath the line for the geometric tolerance.
- Datum feature shift should be entered on the next line beneath the line for the bonus tolerance.
- This approach reflects the fact that there is more than one possible contributions

Dimension And Tolerance Entry – GD & T

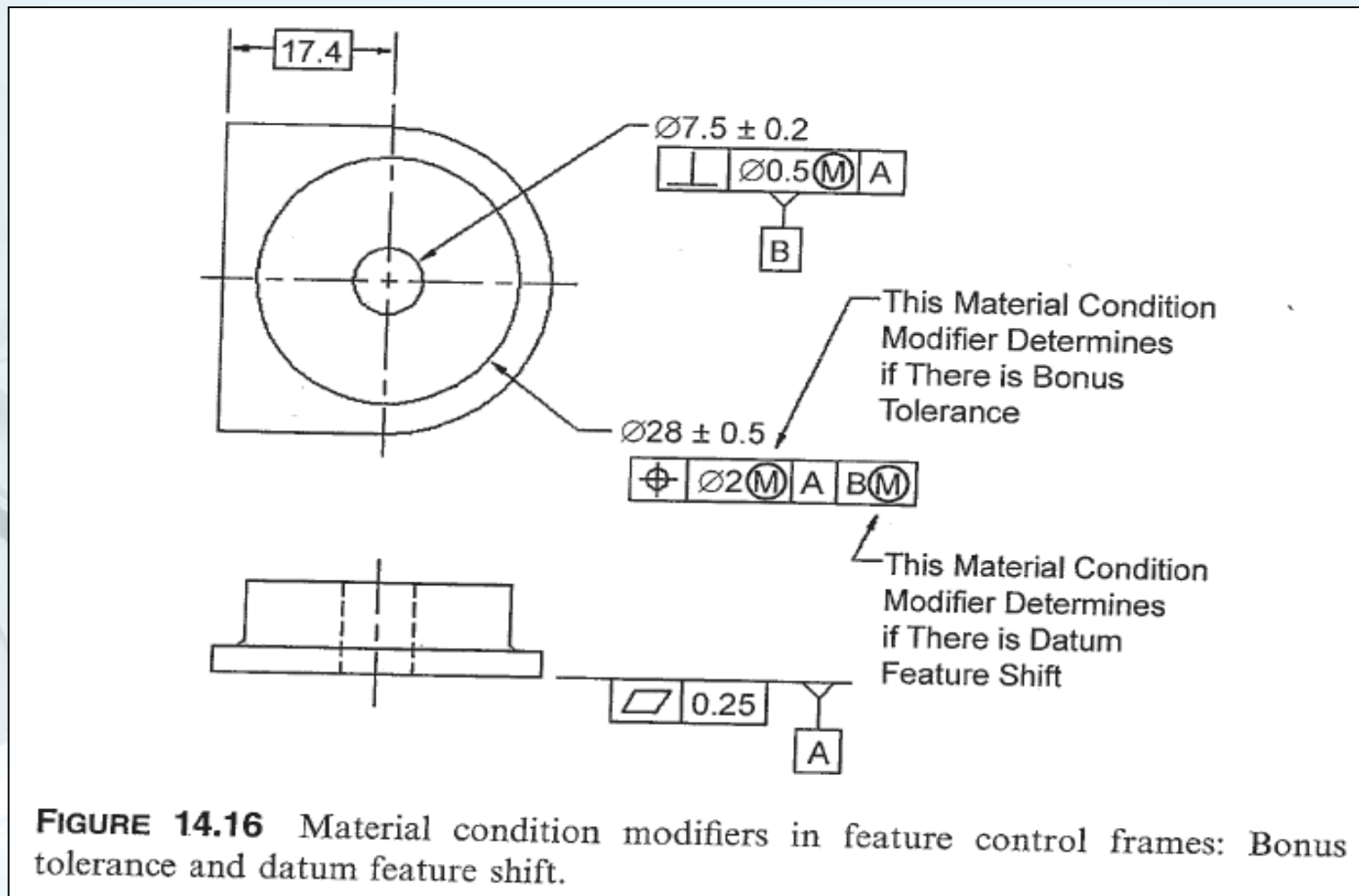

### Dimension And Tolerance Entry – GD & T

- The same number of lines should be entered into the Tolerance Stack up report form for all like geometric tolerances, regardless if they are specified regardless of feature size (RFS) or with a datum reference frame that does not have datum feature shift.
- This means that all profile tolerances will have two lines, all positional tolerances will have three lines, etc.

### Dimension And Tolerance Entry – Profile

- **Profile tolerances**

never a bonus tolerance, possibility of datum feature shift

entered into the Tolerance Stack up report form on two lines:

1. profile tolerance
2. datum feature shift.

an unequal bilateral or unilateral format: must be converted to equal bilateral format.



Dimension And Tolerance Entry – Profile

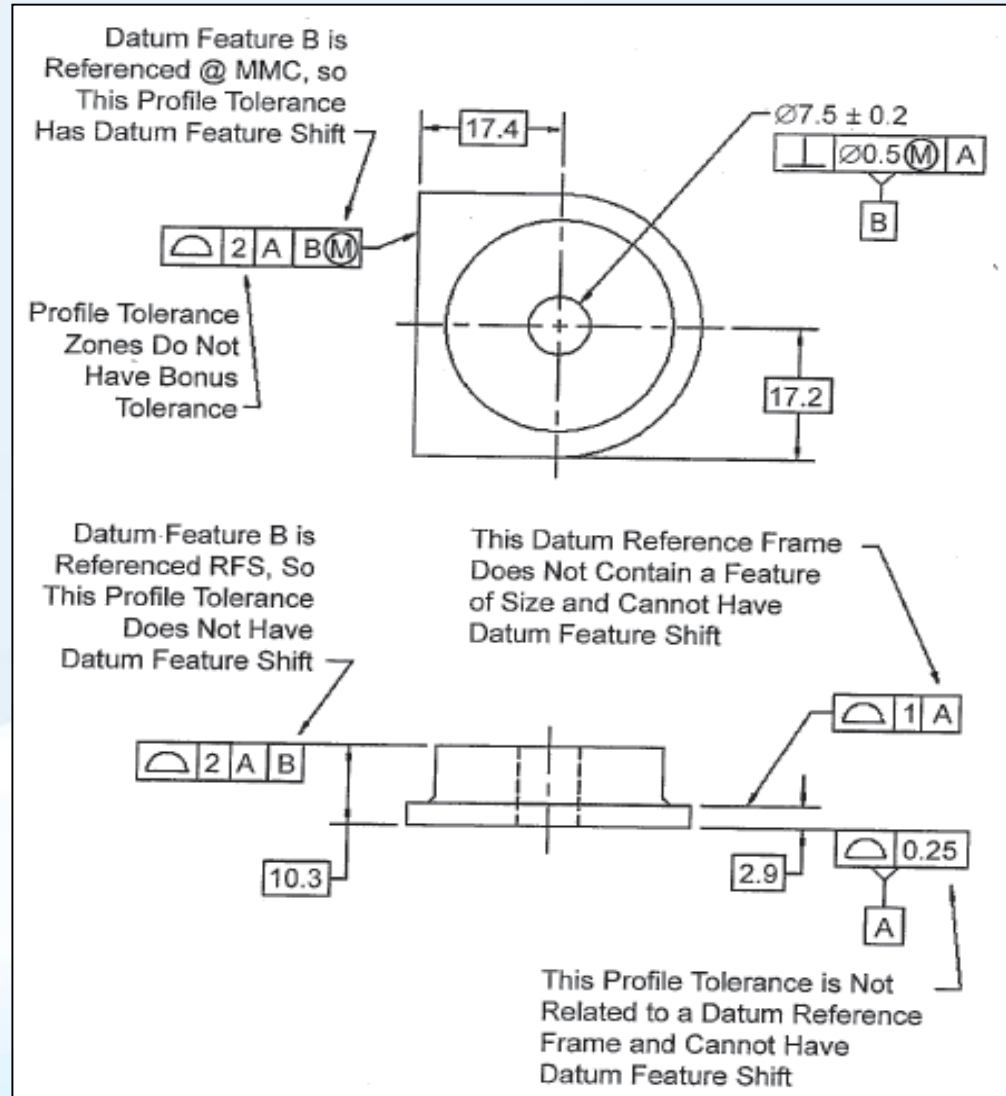

## Dimension And Tolerance Entry – Profile

Item	Description	+ Dims	- Dims	Tol	Percent Contrib	Dim / Tol Source & Calcs
1	Profile: Bottom Surface: DF <sub>A</sub>			± 0.1250	10%	Profile 0.25
2	Datum Feature Shift			± 0.0000	0%	N/A - No Datum Reference Frame
3	Dim: DF <sub>A</sub> - Surface @ 2.9mm	2.9000		± 0.0000	0%	2.9 Basic on dwg
				±		

**FIGURE 14.18** Sample Tolerance Stackup report format: Profile tolerance without datum feature shift and without datum reference frame.

Description of Component / Assy	Part Number	Rev	Item	Description	+ Dims	- Dims	Tol	Percent Contrib	Dim / Tol Source & Calcs
Sample Part	ABC-123	A	1	Profile: Bottom Surface: DF <sub>A</sub>			± 0.1250	10%	Profile 0.25
			2	Datum Feature Shift			± 0.0000	3%	N/A - No Datum Reference Frame
			3	Dim: DF <sub>A</sub> - Surface @ 2.9mm	2.9000		± 0.0000	0%	2.9 Basic on dwg
			4	Profile: Surface @ 2.9mm			± 0.5000	25%	Profile 1, A
			5	Datum Feature Shift			± 0.0000	0%	N/A - DF <sub>A</sub> not a Feature of Size

**FIGURE 14.19** Sample Tolerance Stackup report format: Profile tolerance without datum feature shift and without datum features of size.

## Chapter #14 Tolerance Stack-up Report

### Dimension And Tolerance Entry – Profile

Description of Component / Assy	Part Number	Rev	Item	Description	+ Dims	- Dims	Tol	Percent Contrib	Dim / Tol Source & Calcs
Sample Part	ABC-123	A	1	Profile: Bottom Surface: DF <sub>A</sub>			± 0.1250	5%	Profile 0.25
			2	Datum Feature Shift			± 0.0000	0%	N/A - No Datum Reference Frame
			3	Dim: DF <sub>A</sub> - Upper Surface	10.3000		± 0.0000	0%	10.3 Basic on dwg
			4	Profile: Upper Surface			± 1.0000	40%	Profile 2, A, B
			5	Datum Feature Shift			± 0.0000	0%	N/A - DF <sub>B</sub> Specified RFS
							±		

**FIGURE 14.20** Sample Tolerance Stackup report format: Profile tolerance without datum feature shift and with datum features of size specified RFS.

Description of Component / Assy	Part Number	Rev	Item	Description	+ Dims	- Dims	Tol	Percent Contrib	Dim / Tol Source & Calcs
Sample Part	ABC-123	A	1	Profile: Bottom Surface: DF <sub>A</sub>			± 0.1250	5%	Profile 0.25
			2	Datum Feature Shift			± 0.0000	0%	N/A - No Datum Reference Frame
			3	Dim: DF <sub>A</sub> - Upper Surface	10.3000		± 0.0000	0%	10.3 Basic on dwg
			4	Profile: Left Side Surface			± 1.0000	30%	Profile 2, A, B @ MMC
			5	Datum Feature Shift			± 0.4500	15%	$= [(7.5 + 0.2) - (7.5 - 0.2 - 0.5)]/2$

**FIGURE 14.21** Sample Tolerance Stackup report format: Profile tolerance with datum feature shift.

### Dimension And Tolerance Entry – Positional Tolerance

- Positional tolerance information: three lines.
  1. The positional tolerance
  2. bonus tolerance
  3. datum feature shift





## Chapter #14 Tolerance Stack-up Report

### Dimension And Tolerance Entry – Positional Tolerance

Description of Component / Assy	Part Number	Rev	Item	Description	+ Dims	- Dims	Tol	Percent Contrib	Dim / Tol Source & Calcs
Sample Part	ABC-123	A	1	Position: DF <sub>B</sub>			± 0.1250	10%	Position dia 0.25 @ MMC, A
			2	Bonus Tolerance			± 0.1000	8%	= (0.1 + 0.1)/2
			3	Datum Feature Shift			± 0.0000	0%	N/A - DF <sub>A</sub> not a Feature of Size
			4	Dim: DF <sub>B</sub> - DF <sub>C</sub>	35.0000		± 0.0000	0%	35 Basic on Dwg

**FIGURE 14.23** Sample Tolerance Stackup report format: Positional tolerance with bonus tolerance and without datum features of size.

Description of Component / Assy	Part Number	Rev	Item	Description	+ Dims	- Dims	Tol	Percent Contrib	Dim / Tol Source & Calcs
Sample Part	ABC-123	A	1	Position: DF <sub>B</sub> Hole			± 0.1250	10%	Position dia 0.25 @ MMC, A
			2	Bonus Tolerance			± 0.1000	8%	= (0.1 + 0.1)/2
			3	Datum Feature Shift			± 0.0000	0%	N/A - DF <sub>A</sub> not a Feature of Size
			4	Dim: DF <sub>B</sub> - DF <sub>C</sub>	35.0000		± 0.0000	0%	35 Basic on Dwg
			5	Position: DF <sub>C</sub> Hole			± 0.2500	20%	Position dia 0.5, A, B @ MMC
			6	Bonus Tolerance			± 0.0000	0%	N/A - RFS
			7	Datum Feature Shift			± 0.2250	18%	= [(6 + 0.1) - (6 - 0.1 - 0.25)]/2

**FIGURE 14.24** Sample Tolerance Stackup report format: Positional tolerance without bonus tolerance and with datum feature shift.



### Dimension And Tolerance Entry – Positional Tolerance

Description of Component / Assy	Part Number	Rev	Item	Description	+ Dims	- Dims	Tol	Percent Contrib	Dim / Tol Source & Calcs
Sample Part	ABC-123	A	1	Position: DF <sub>B</sub> Hole			± 0.1250	10%	Position dia 0.25 @ MMC, A
			2	Bonus Tolerance			± 0.1000	8%	= (0.1 + 0.1)/2
			3	Datum Feature Shift			± 0.0000	0%	N/A - DF <sub>A</sub> not a Feature of Size
			4	Dim: DF <sub>B</sub> - DF <sub>C</sub>	35.0000		± 0.0000	0%	35 Basic on Dwg
			5	Position: 4X Dia 4.7 ± 0.2 Holes			± 0.2500	20%	Position dia 0.5, A, C, D
			6	Bonus Tolerance			± 0.2000	15%	= (0.2 + 0.2)/2
			7	Datum Feature Shift			± 0.0000	0%	N/A - Datum Features Referenced RFS

**FIGURE 14.25** Sample Tolerance Stackup report format: Positional tolerance with bonus tolerance and without datum feature shift.

Description of Component / Assy	Part Number	Rev	Item	Description	+ Dims	- Dims	Tol	Percent Contrib	Dim / Tol Source & Calcs
Sample Part	ABC-123	A	1	Position: DF <sub>B</sub> Hole			± 0.1250	10%	Position dia 0.25 @ MMC, A
			2	Bonus Tolerance			± 0.1000	8%	= (0.1 + 0.1)/2
			3	Datum Feature Shift			± 0.0000	0%	N/A - DF <sub>A</sub> not a Feature of Size
			4	Dim: DF <sub>B</sub> - Dia 4 Holes	30.0000		± 0.0000	0%	30 Basic on Dwg
			5	Position: 2X Dia 4 ± 0.25 Holes			± 0.7500	60%	Position dia 1.5, A, B @ MMC
			6	Bonus Tolerance			± 0.2500	20%	= (0.25 + 0.25)/2
			7	Datum Feature Shift			± 0.2250	18%	= [(6 + 0.1) - (6 - 0.1 - 0.25)]/2

**FIGURE 14.26** Sample Tolerance Stackup report format: Positional tolerance with bonus tolerance and with datum feature shift.

### Dimension And Tolerance Entry – Orientation Tolerance

- An orientation tolerance applied to a flat surface may need to be included in a Tolerance Stack up in cases where the orientation of the surface can cause other features to tilt, reducing or increasing the gap or interference being studied.
- Orientation tolerance zones specified for flat surfaces or other surfaces: no bonus tolerance, but datum feature shift may allowed.
- Sometimes only the orientation of a hole matters, as it may cause other features to tilt, thereby reducing or increasing a gap or interference being studied. In such a case the orientation tolerance would be included in the Tolerance Stack up.

### Dimension And Tolerance Entry – Orientation Tolerance

- an orientation tolerance is included in the Tolerance Stack up if the orientation tolerance is applied to a secondary datum feature of size.
- Orientation tolerances: Three lines
  - 1.orientation tolerance
  2. bonus tolerance
  3. datum feature shift

### Dimension And Tolerance Entry – Orientation Tolerance

The more datum feature B tilts. The perpendicularity tolerance applied to datum feature B must be included in the Tolerance Stack up to determine the minimum wall thickness.

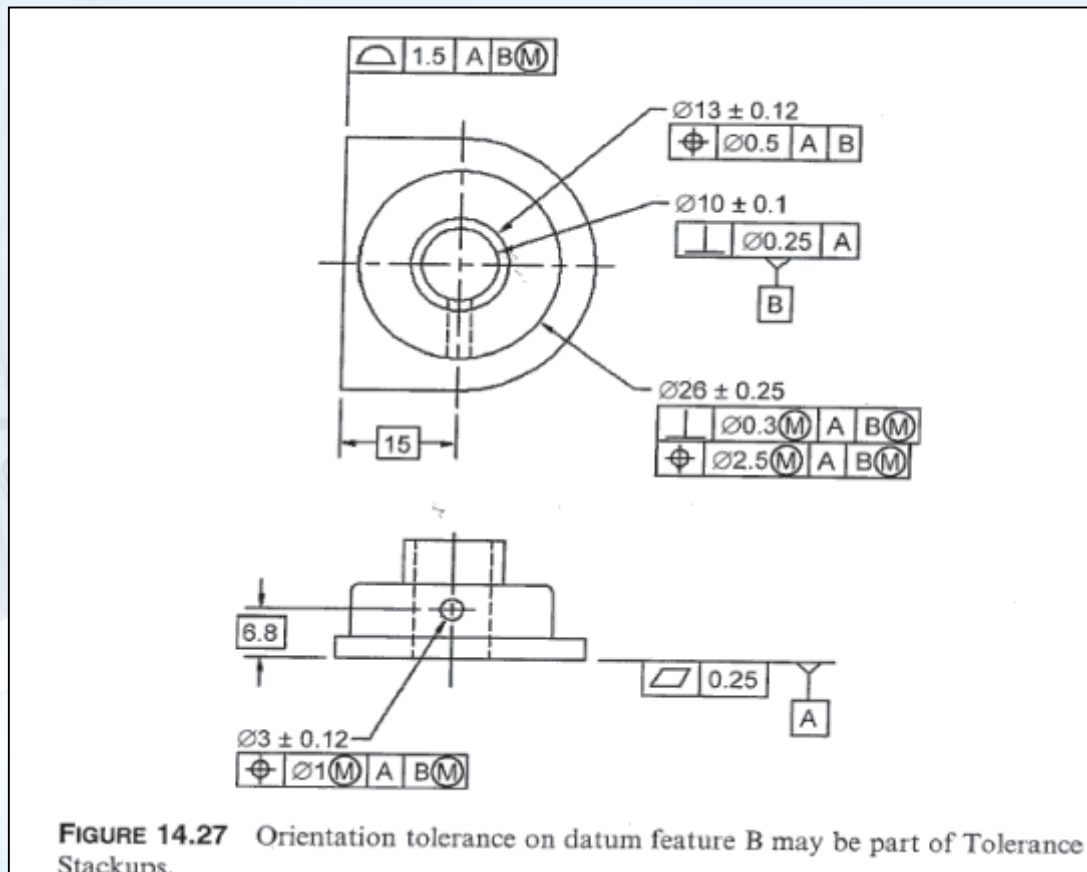

### Dimension And Tolerance Entry – Form Tolerance

- The possible effect of a form tolerance on the Tolerance Stack up depends on several factors:

Interface geometry

How the interface geometry relates to the part geometry being studied

Whether the interfacial surfaces are subject to deformation at assembly, e.g. whether the interfacial surfaces subjected to axial loading from fasteners

### Dimension And Tolerance Entry – Run out Tolerance

- Run out tolerance information is entered into the Tolerance Stack up report form on two lines.
  1. run out tolerance
  2. datum feature shift
- A run out tolerance may only be specified RFS, so there is no bonus tolerance.



# Chapter #15

QUALITY

## Tolerance Stack-up with Trigonometry





Direction of dimensions in the Tolerance Stack up.

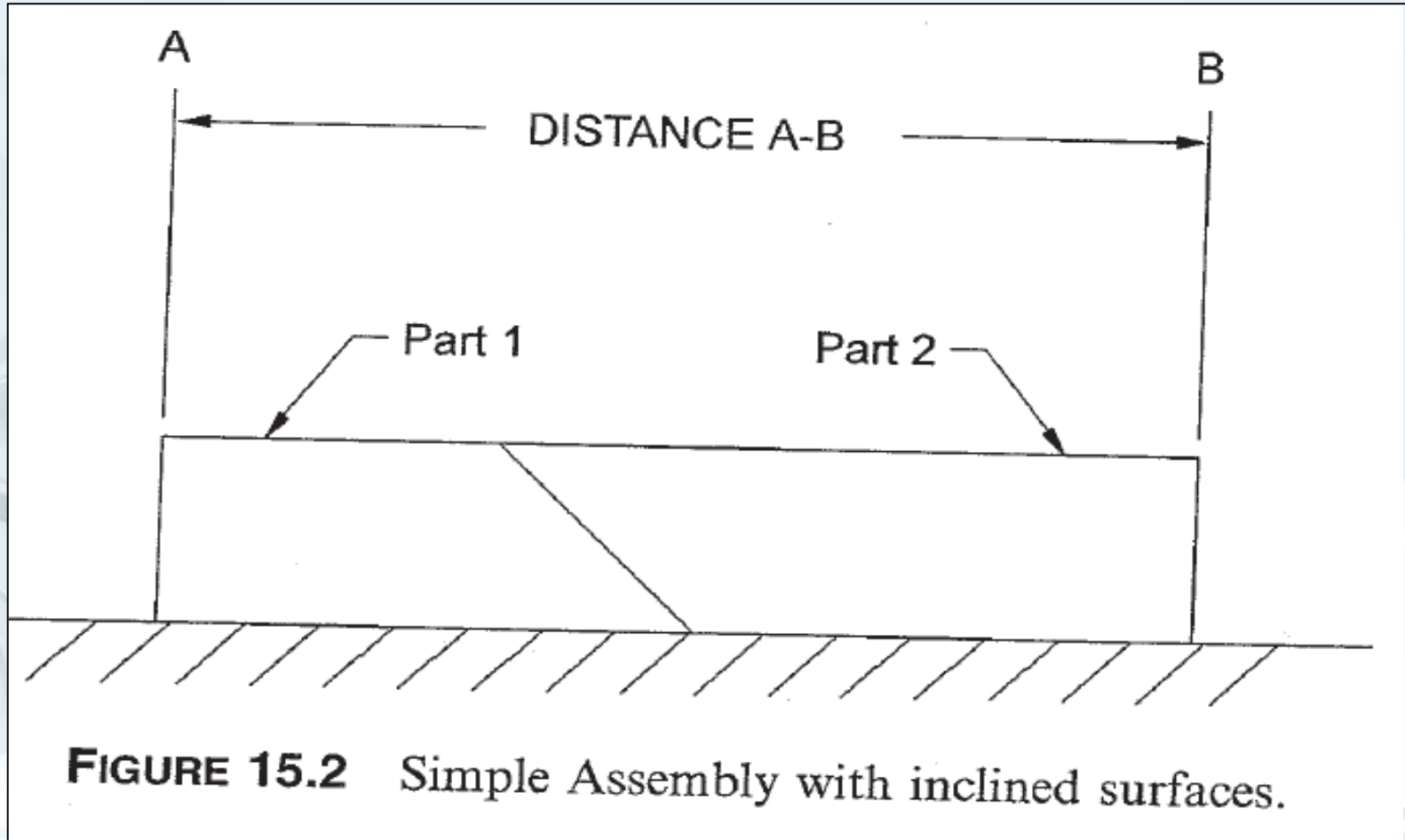

Direction of dimensions in the Tolerance Stack up.

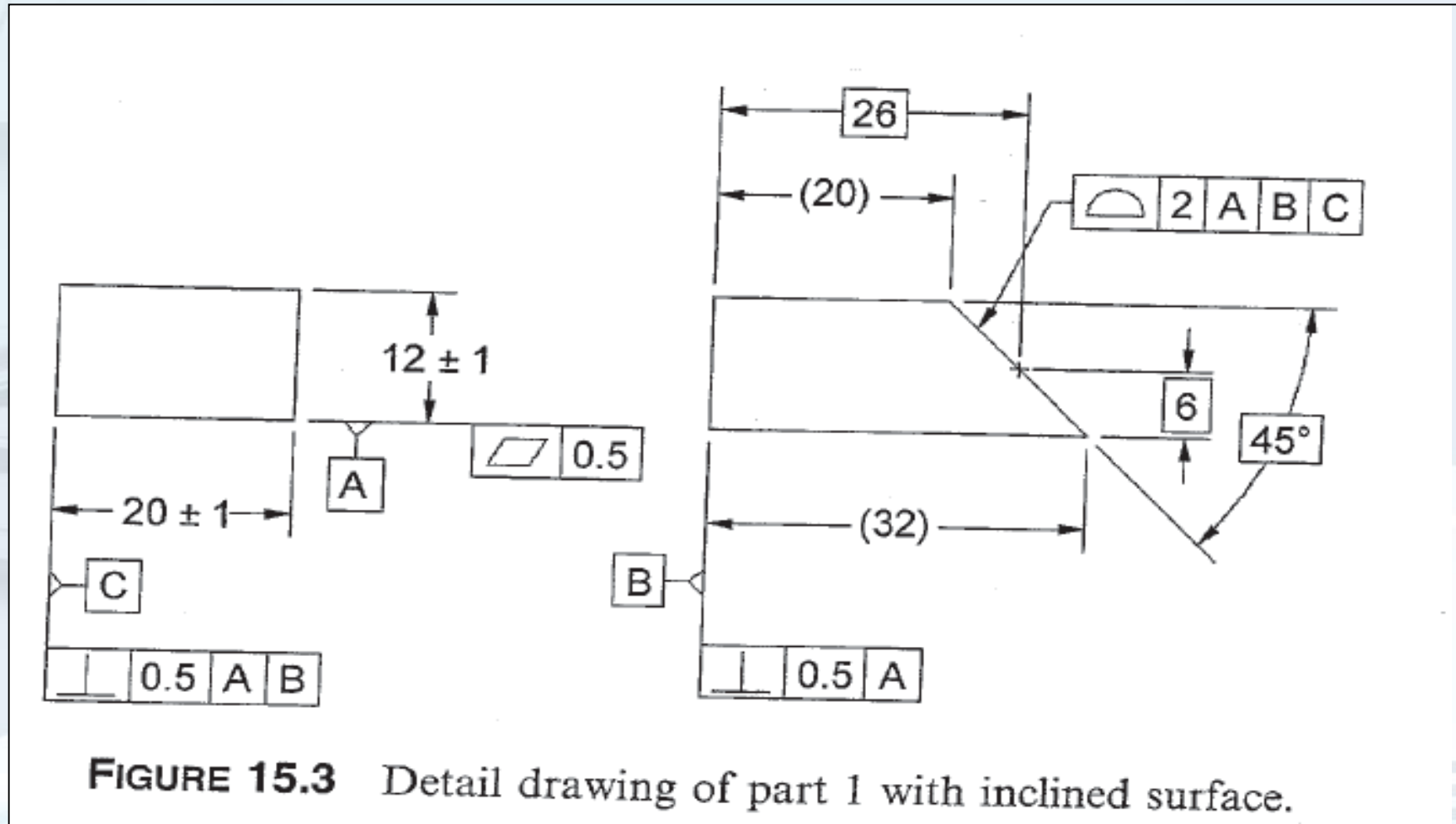

## Direction of dimensions in the Tolerance Stack up.

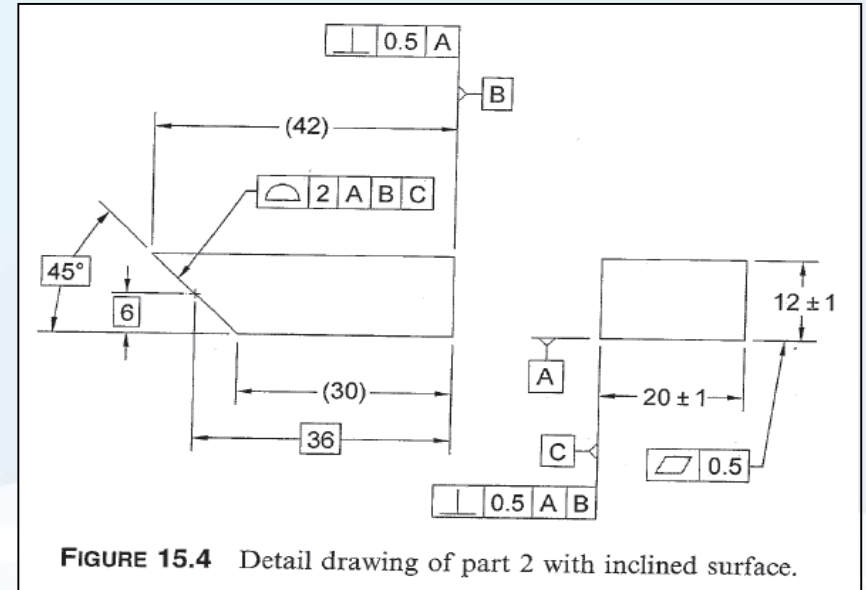
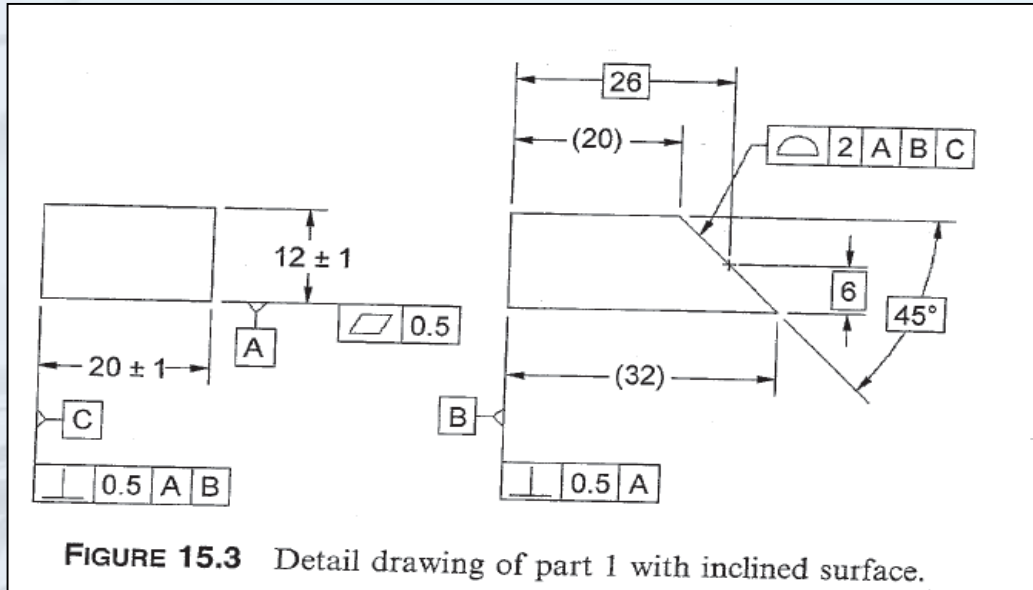





# Chapter #15 Tolerance Stack-up with Trigonometry

## Direction of dimensions in the Tolerance Stack up.

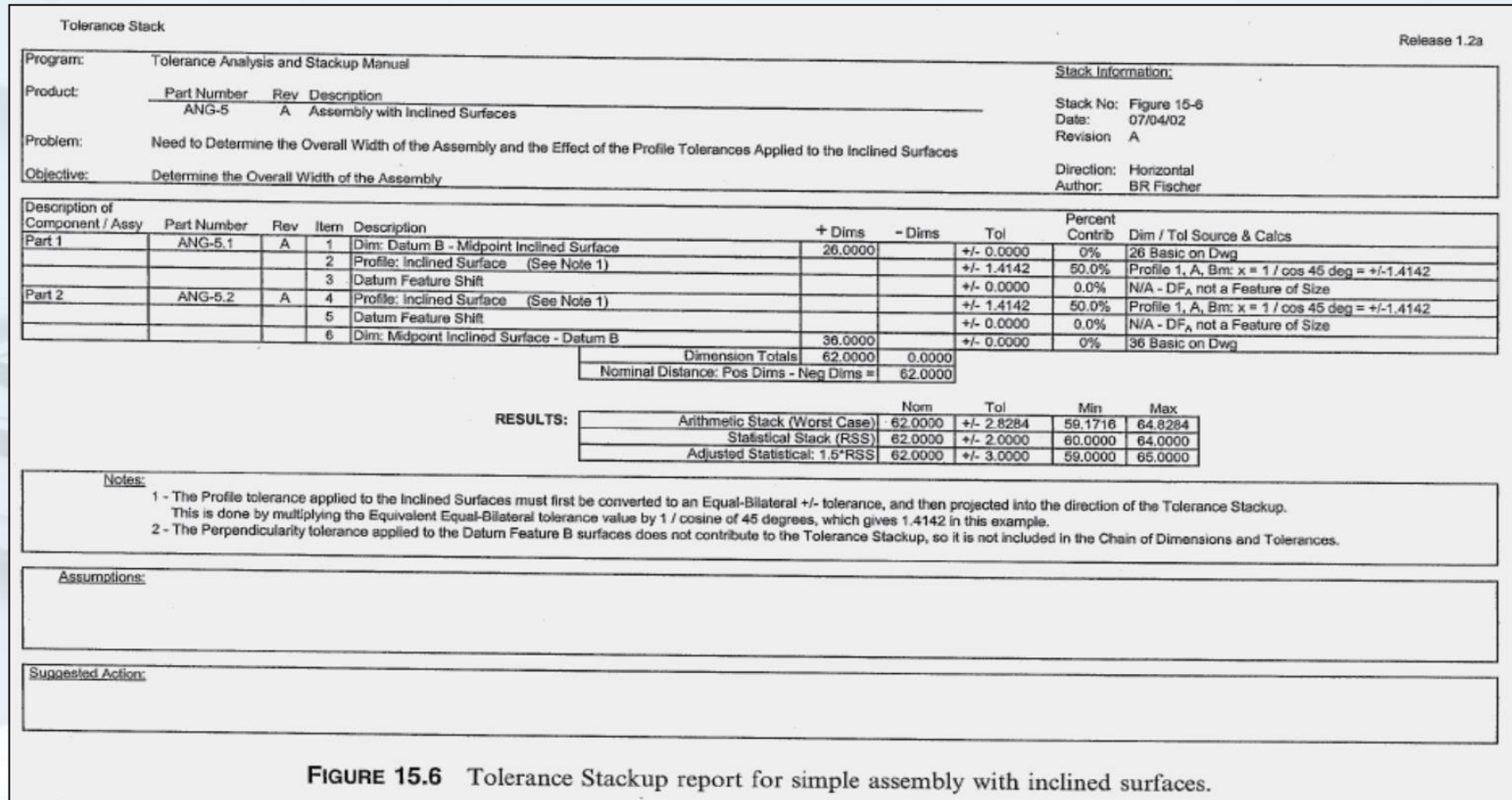
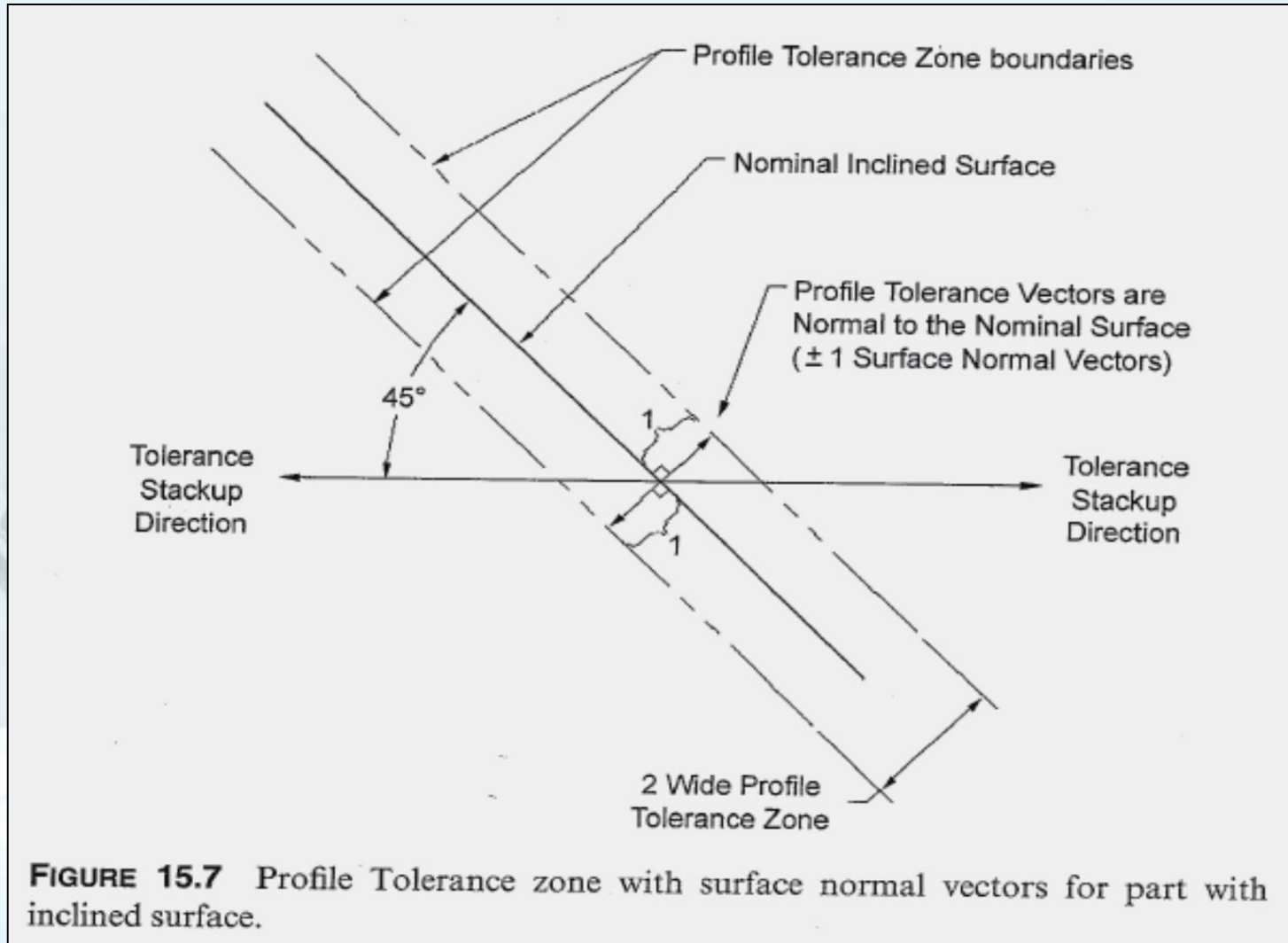
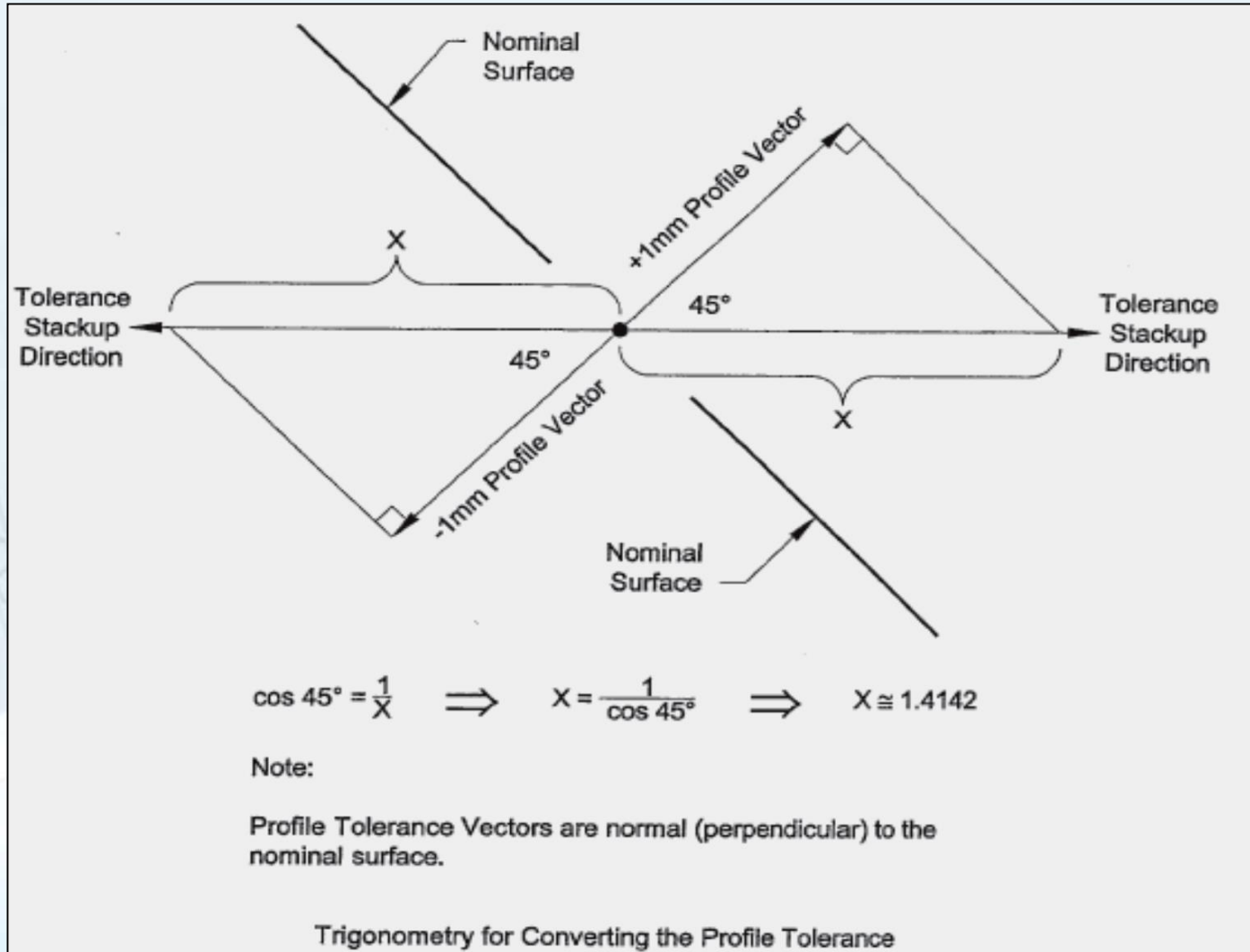

FIGURE 15.6 Tolerance Stackup report for simple assembly with inclined surfaces.

## Trigonometry for Converting Profile Tolerance



### Trigonometry for Converting Profile Tolerance



## Direction of dimensions in the Tolerance Stack up.

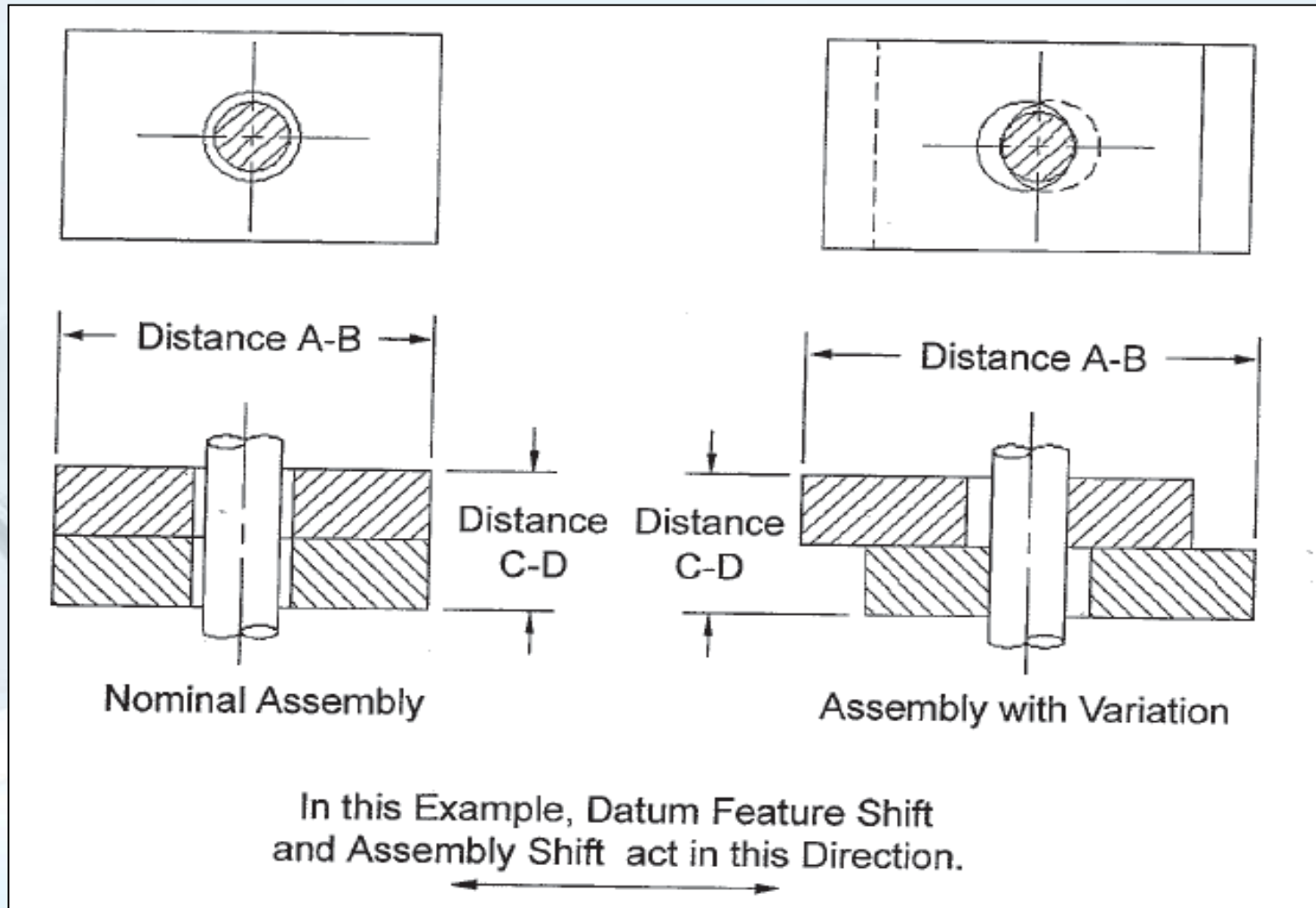

Converting Angular Dimensions And Tolerances Using Trigonometry

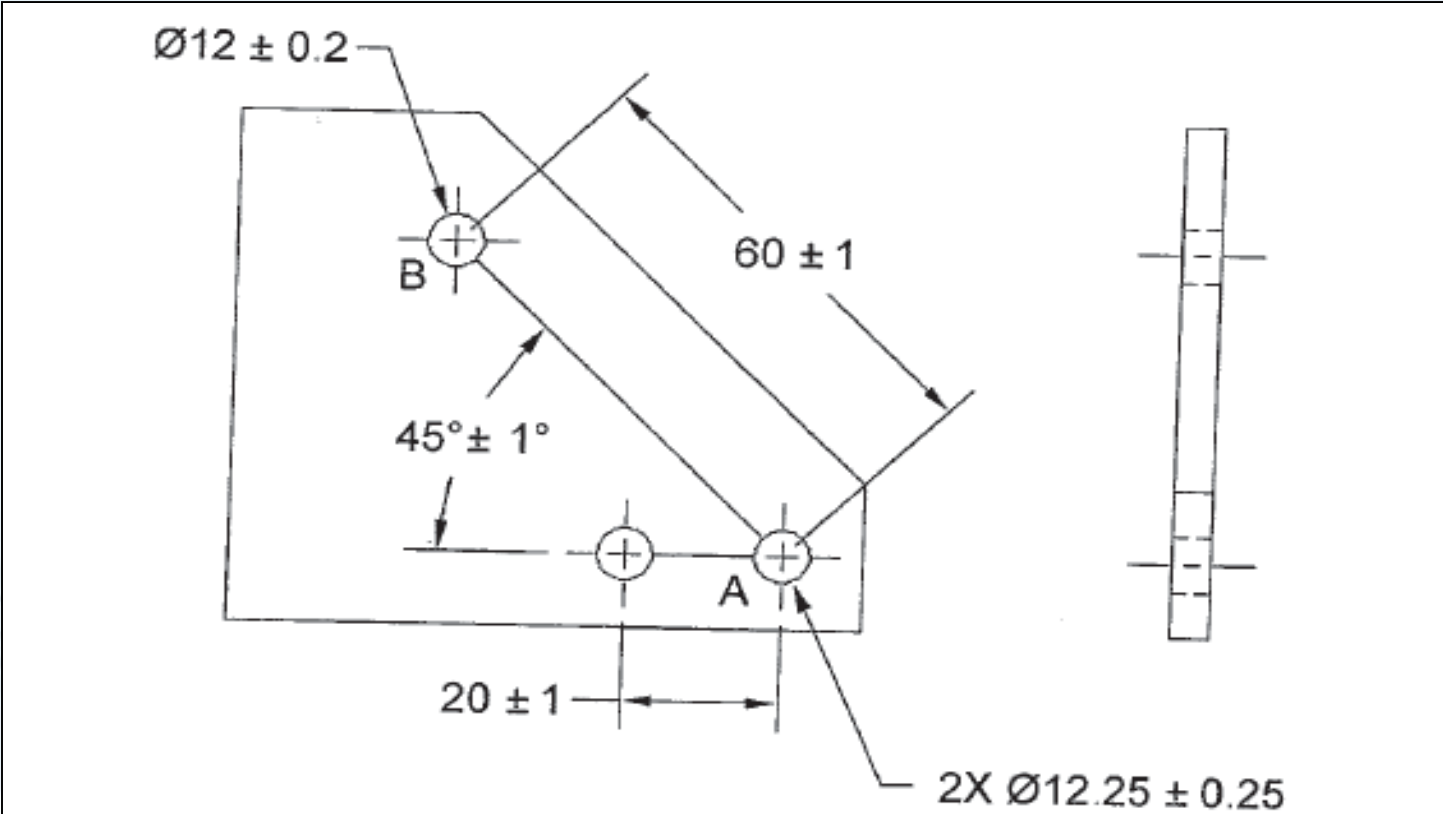
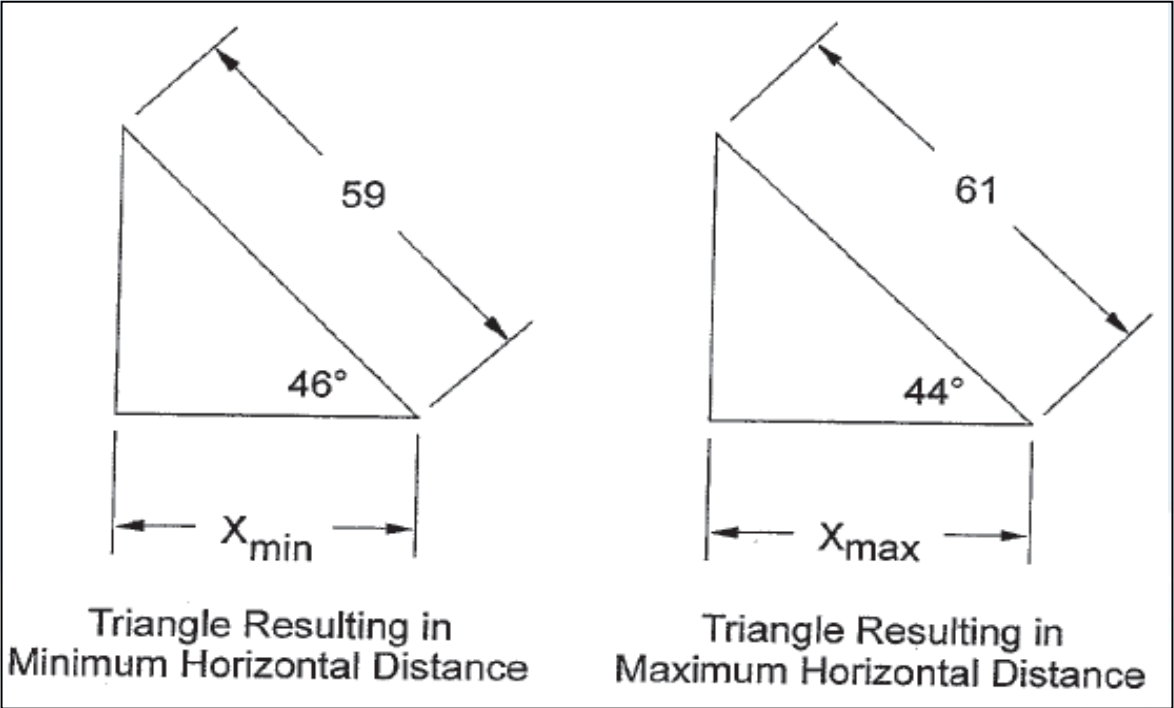
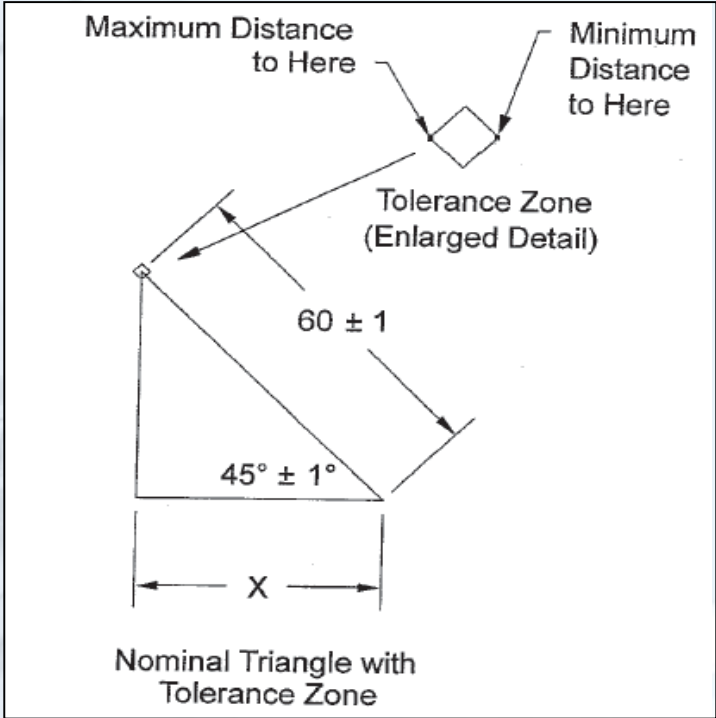

FIGURE 15.12 Part with Dimension and Tolerance at an angle.

Equal bilateral equivalent =  $42.43 \pm 1.45$



# Converting Angular Dimensions And Tolerances Using Trigonometry







### Converting Angular Basic Dimension to Horizontal Equivalent

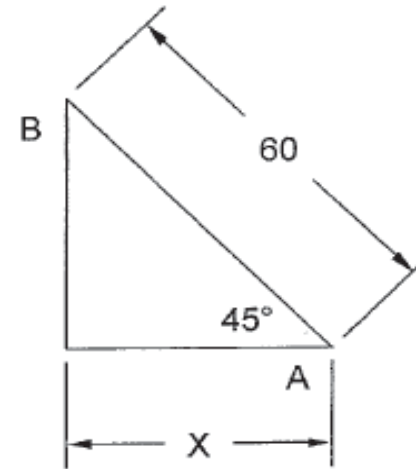
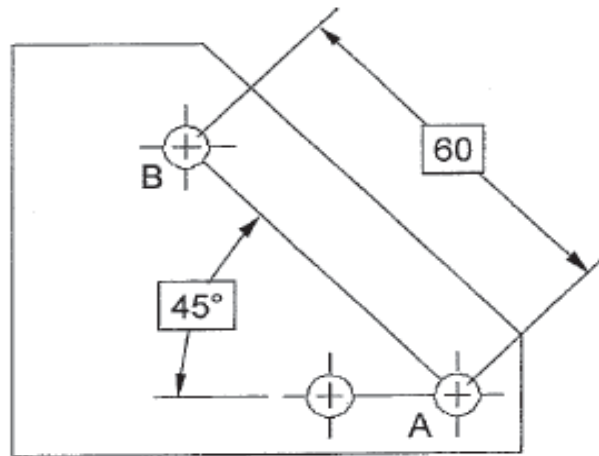

Equivalent Triangle

#### Nominal Calculations:

$$\cos 45^\circ = X/60$$

$$X = 60 \cos 45^\circ$$

$$X = 42.43$$

Equal bilateral equivalent =  $42.43 \pm 1$

### Tolerance Stack up Units

- **A Tolerance Stack up cannot combine units; that is, the summations done in a Tolerance Stack up must be done using only one type of units:**
  - 1. linear units:  
gap, distance, space, overlap, and displacement**
  - 2. angular units:  
tilt, angle, rotation, and inclination**

Rotation Of Parts Within A Linear Tolerance Stack up

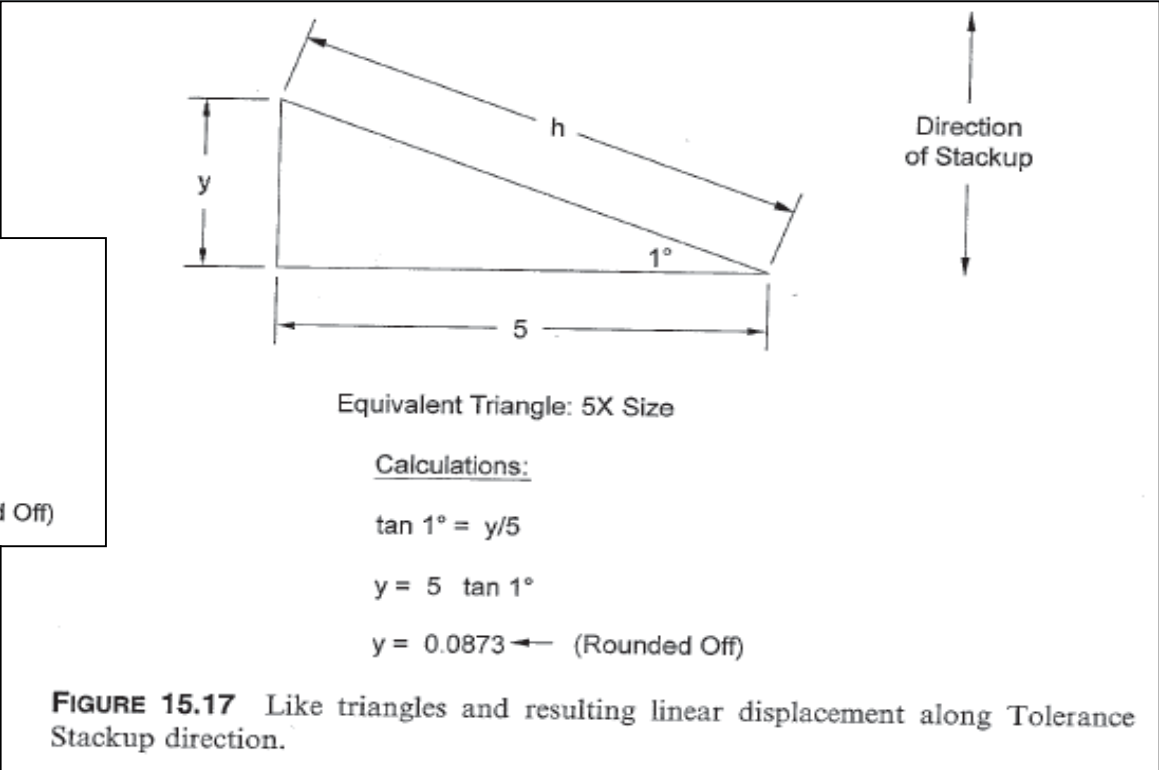
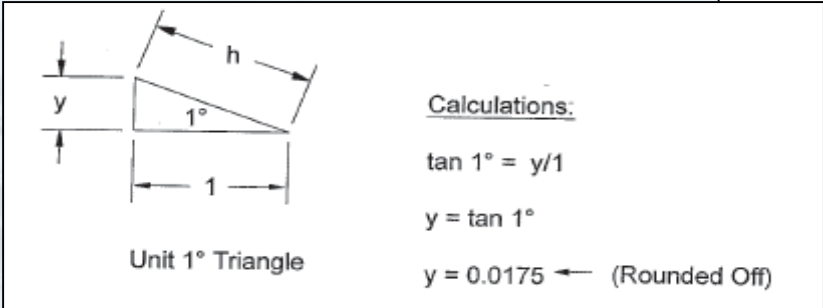

Rotation Of Parts Within A Linear Tolerance Stack up

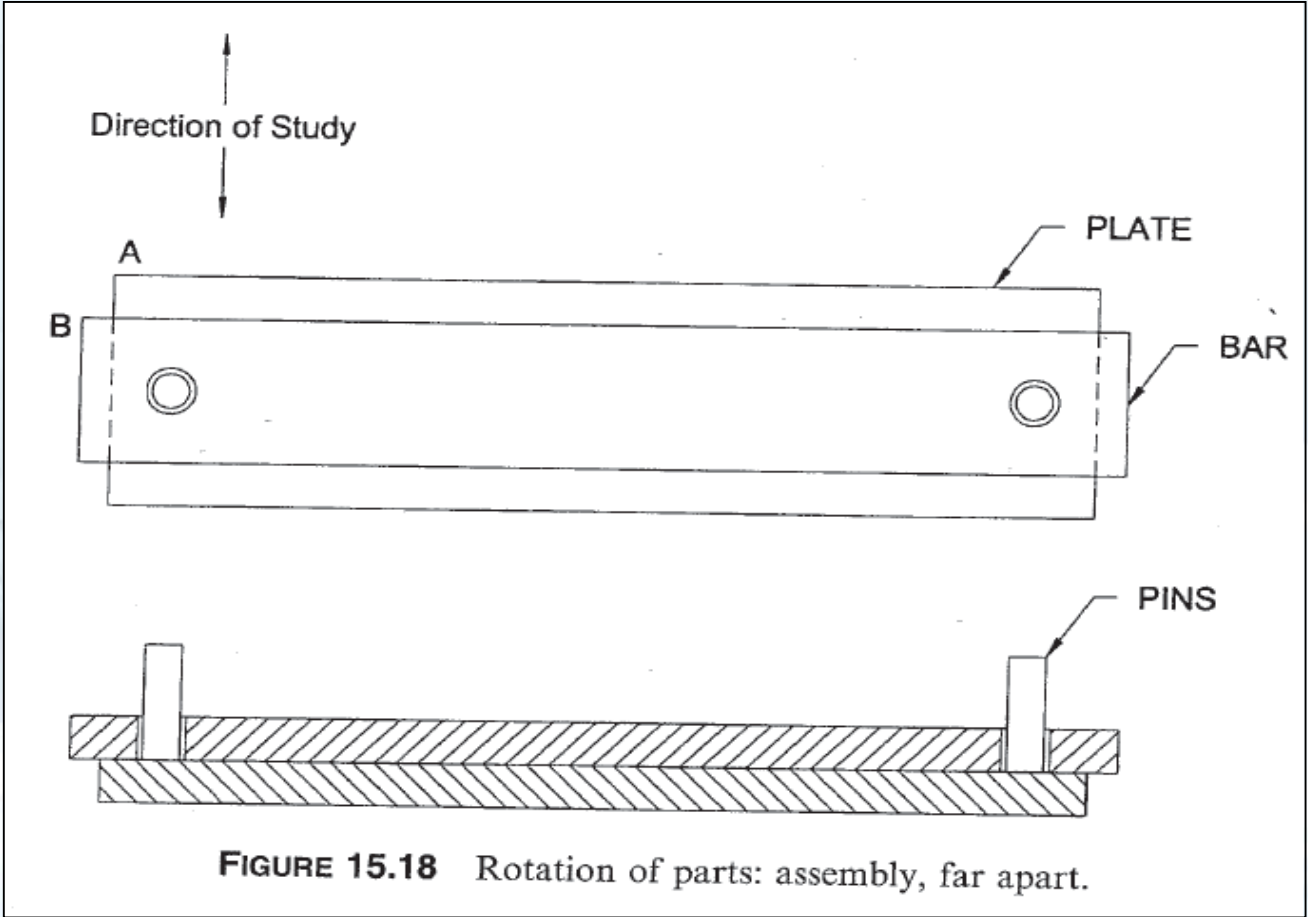
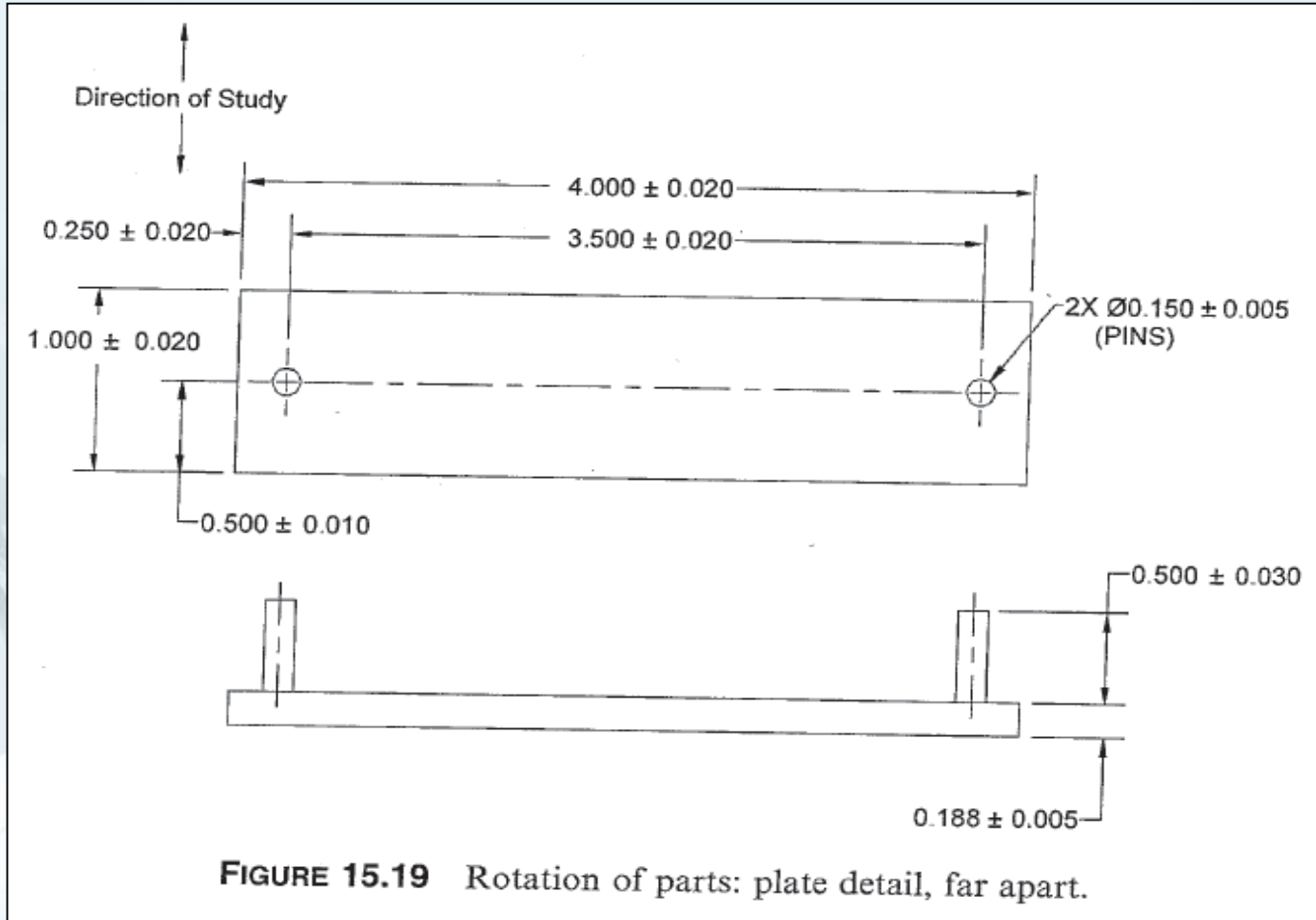

FIGURE 15.18 Rotation of parts: assembly, far apart.

## Rotation Of Parts Within A Linear Tolerance Stack up





Rotation Of Parts Within A Linear Tolerance Stack up

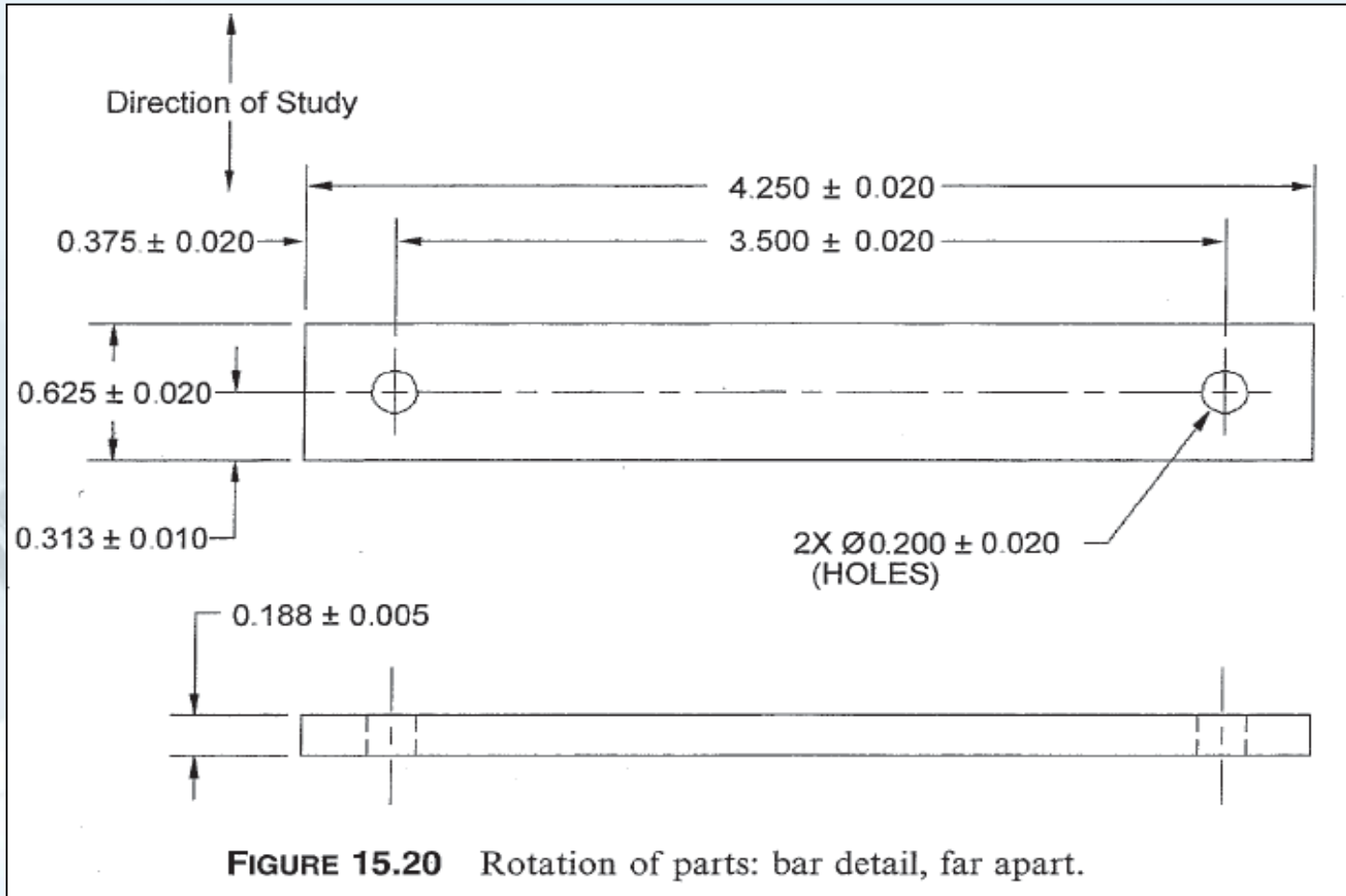

FIGURE 15.20 Rotation of parts: bar detail, far apart.

Rotation Of Parts Within A Linear Tolerance Stack up

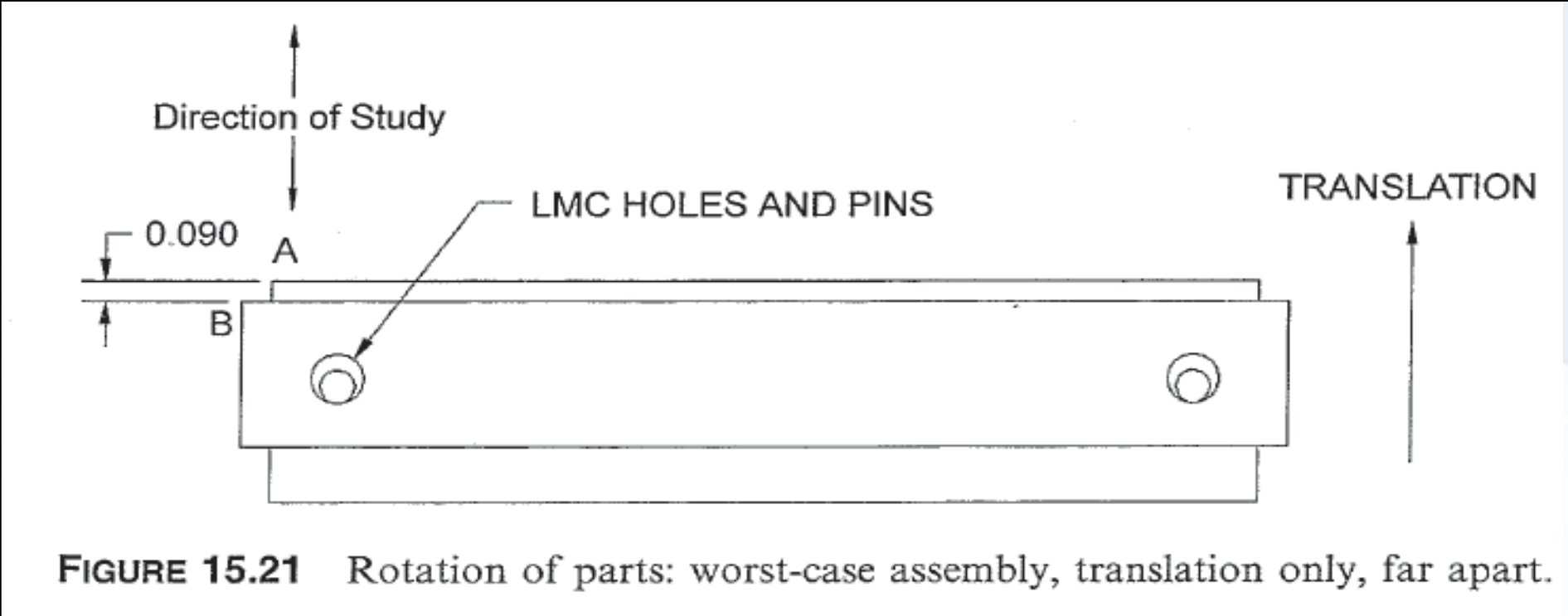
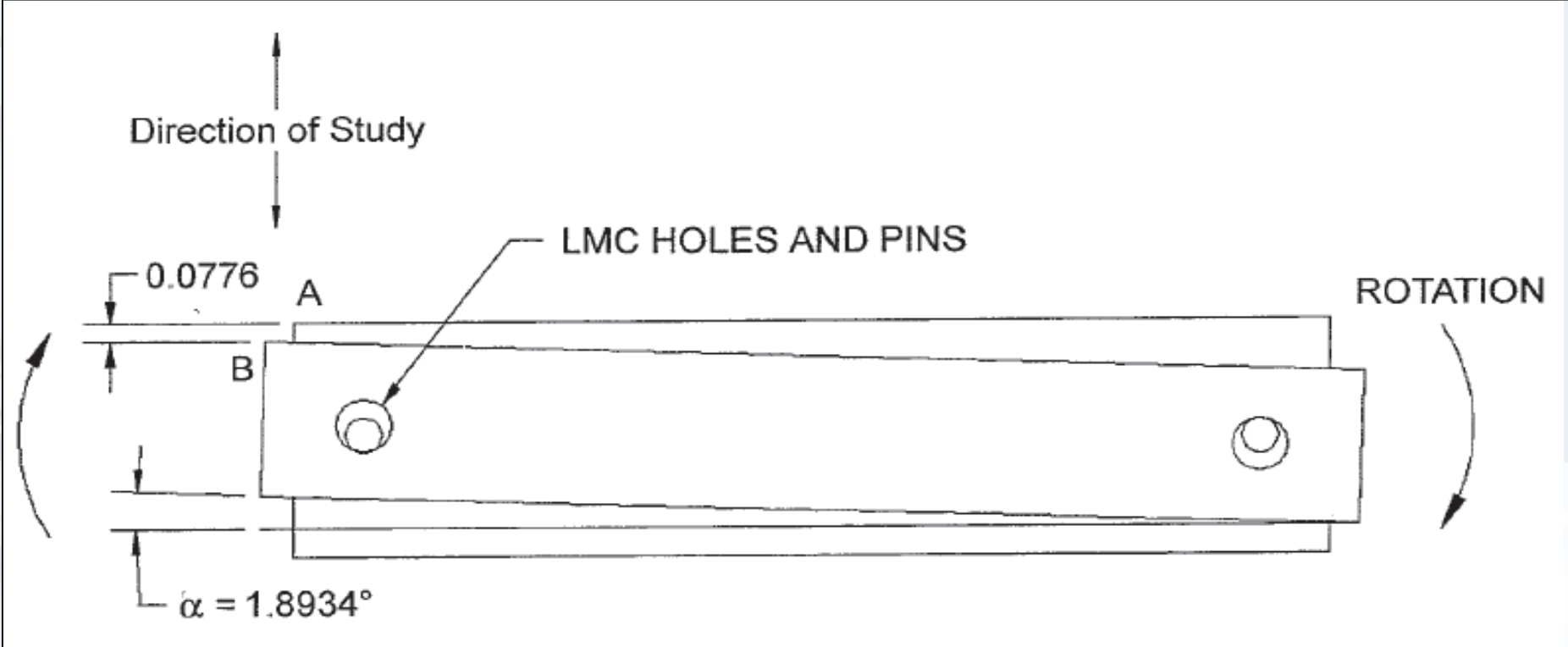

FIGURE 15.21 Rotation of parts: worst-case assembly, translation only, far apart.

Rotation Of Parts Within A Linear Tolerance Stack up



**FIGURE 15.23** Rotation of parts: worst-case assembly, translation and rotation, far apart.

# Chapter #15 Tolerance Stack-up with Trigonometry

## Rotation Of Parts Within A Linear Tolerance Stack up

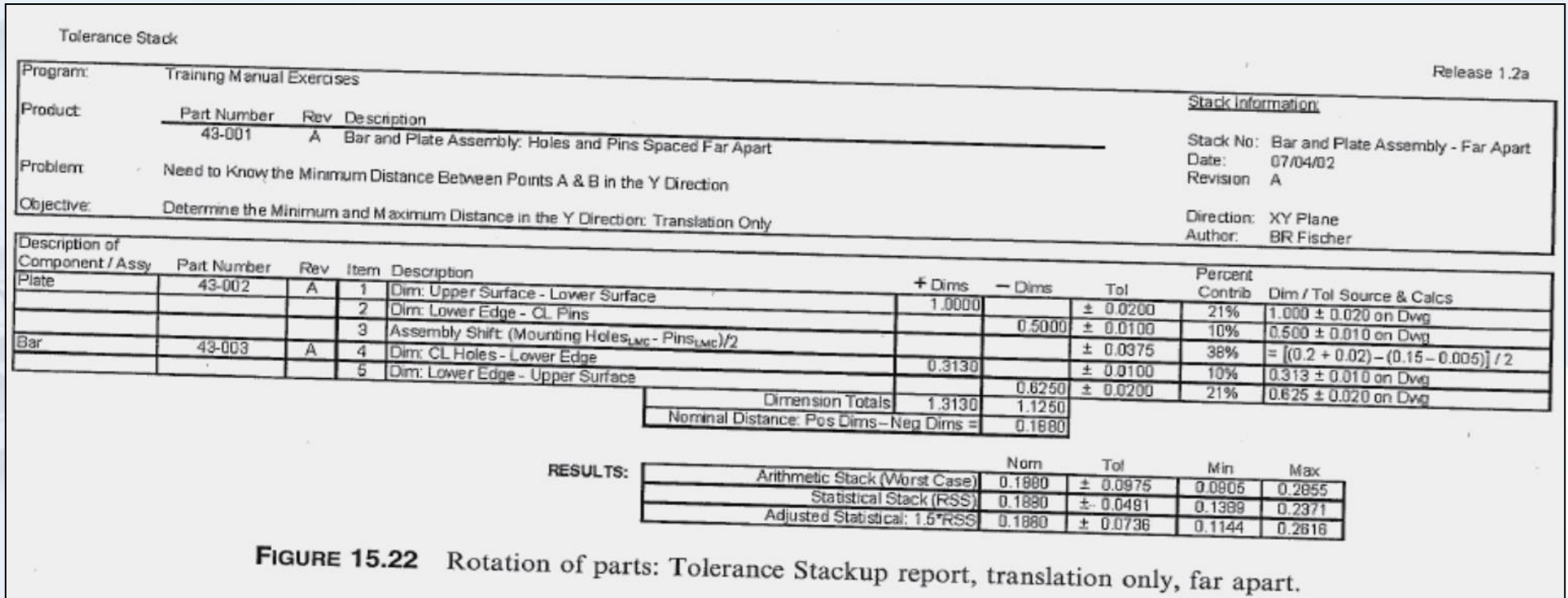

## Rotation Of Parts Within A Linear Tolerance Stack up

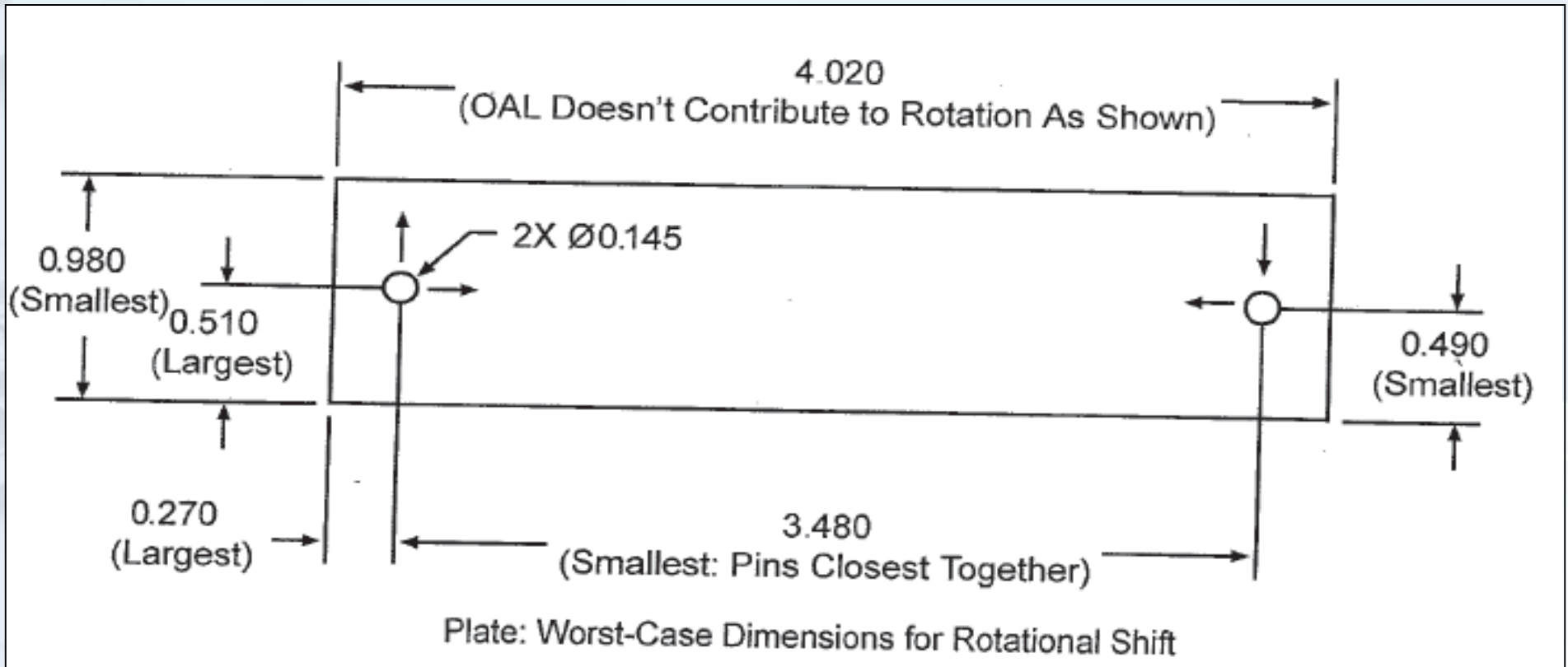

Rotation Of Parts Within A Linear Tolerance Stack up

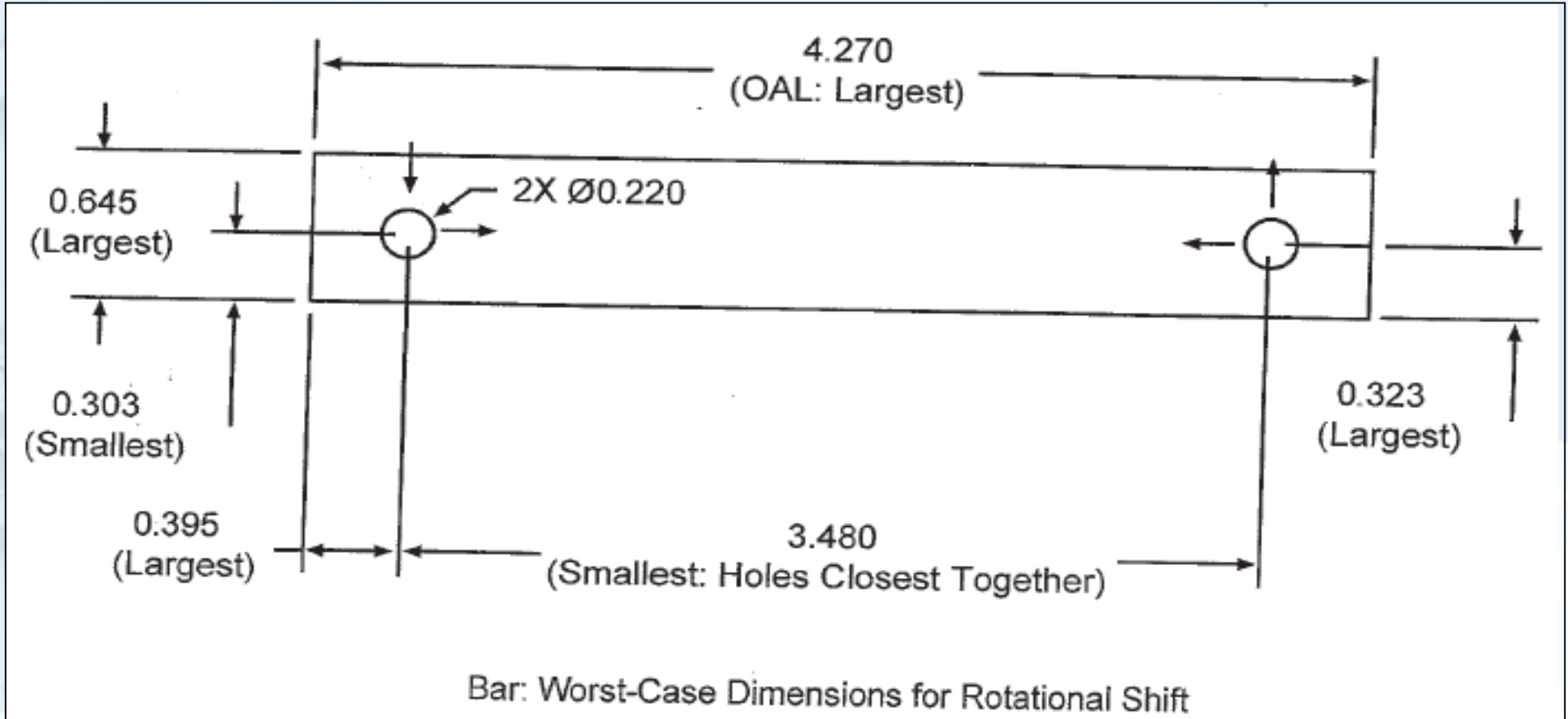



# Chapter #15 Tolerance Stack-up with Trigonometry

## Rotation Of Parts Within A Linear Tolerance Stack up

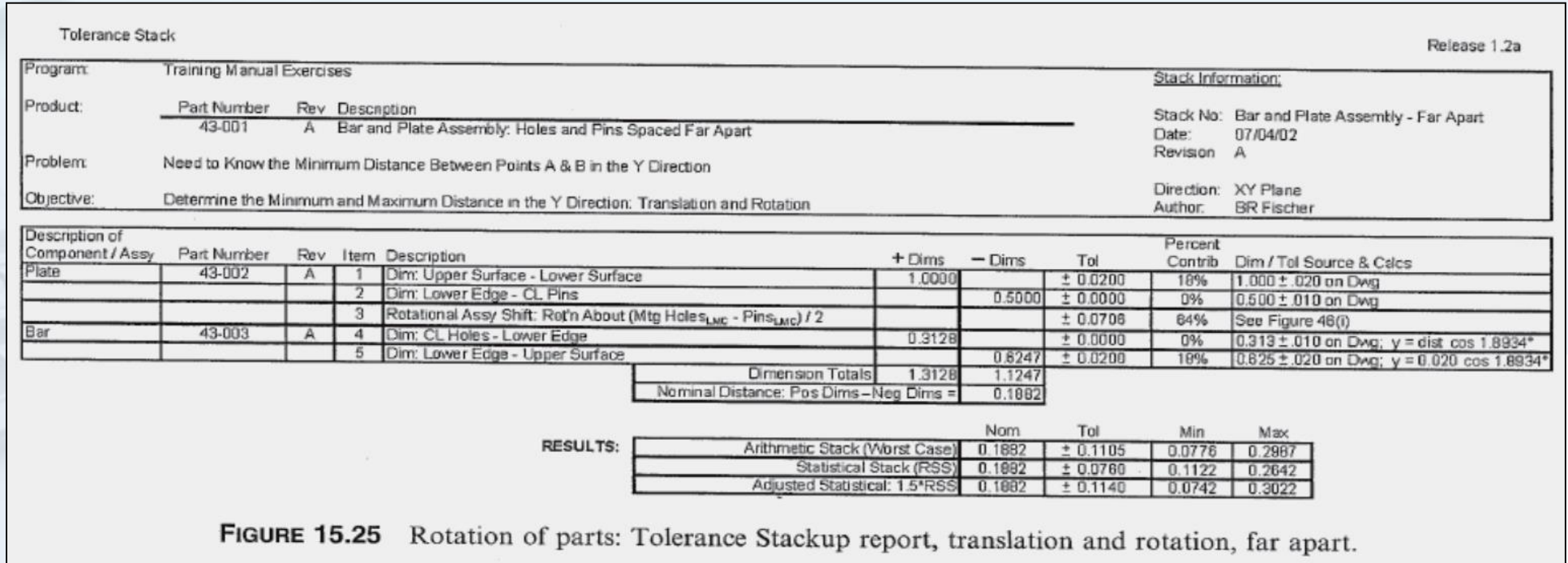

### Rotation Of Parts Within A Linear Tolerance Stack up

Worst-Case rotation occurs when the holes and pins are at the extreme locations discussed in step 1. Their worst-case center-to-center distance ( $d_1$ ) lies along the hypotenuse of the triangles below.

Use the Pythagorean Theorem to calculate center-to-center distance  $d_1$ :

$$d_1 = \sqrt{(\text{Horizontal Distance } x_1)^2 + (\text{Vertical Distance } y_1)^2}$$

$$= 3.48005747$$

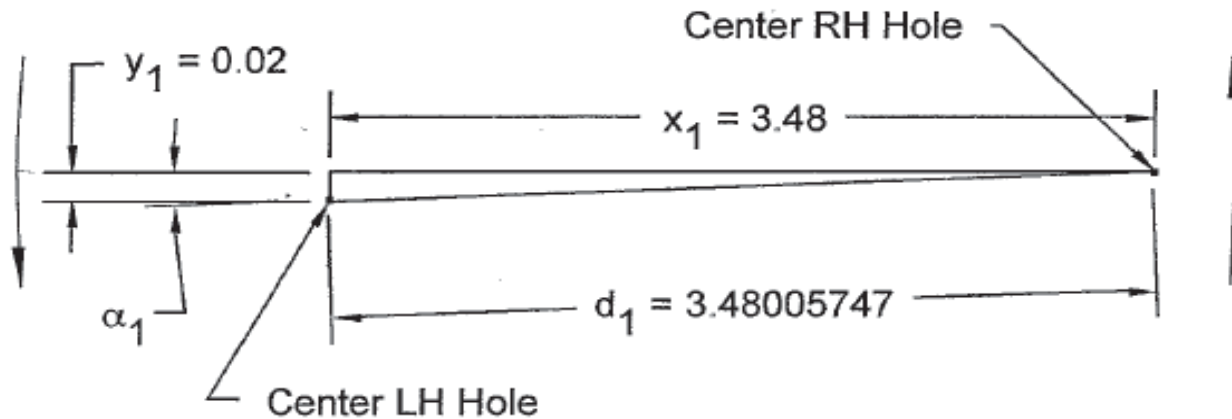

Triangle 1: Worst-case Center-to-Center Distance Between Holes

Rotation Of Parts Within A Linear Tolerance Stack up

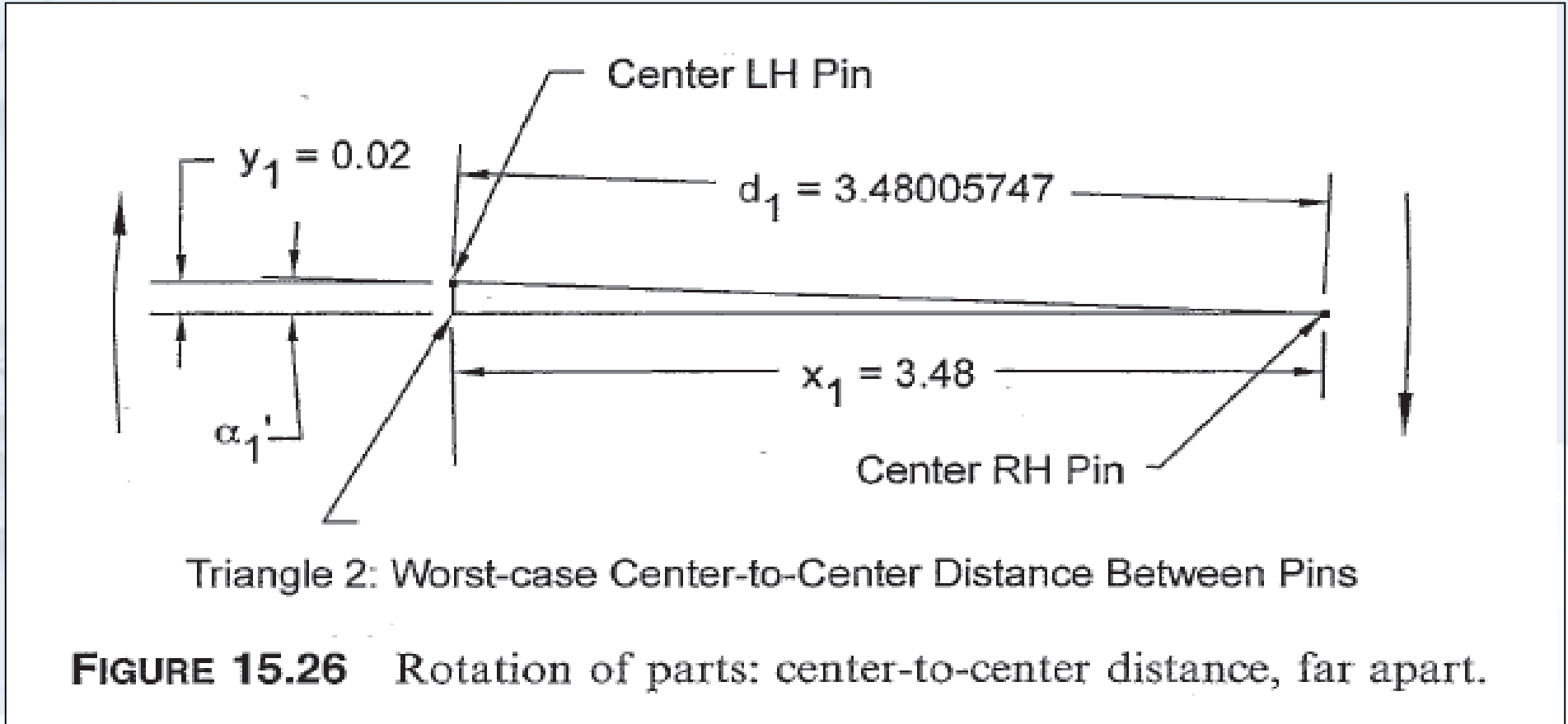

### Rotation Of Parts Within A Linear Tolerance Stack up

$$\text{Solve for } \alpha_1': \quad \tan \alpha_1' = \frac{0.02}{3.48} \quad \Rightarrow \quad \alpha_1' = 0.3293^\circ$$

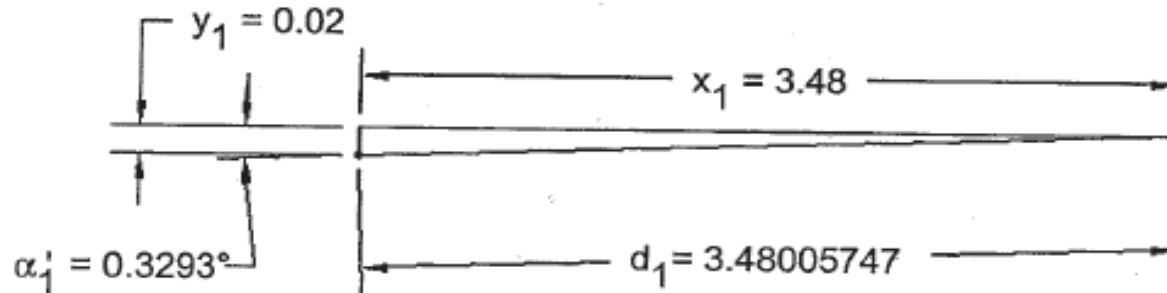

Worst-case Angle from the  $\pm$  Location Tolerances on the Holes

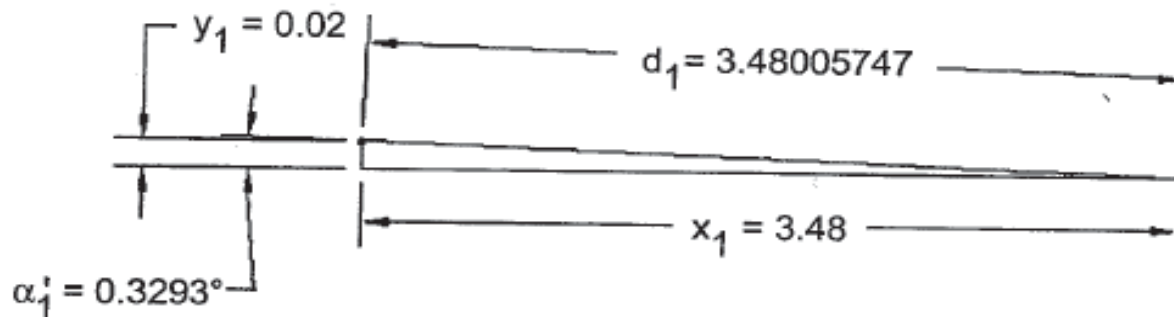

Worst-case Angle from the  $\pm$  Location Tolerances on the Pins

Rotation Of Parts Within A Linear Tolerance Stack up

Solve for  $\alpha_1$ :  $\alpha_1 = \alpha_1' + \alpha_1' = 0.3293^\circ + 0.3293^\circ = 0.6586^\circ$

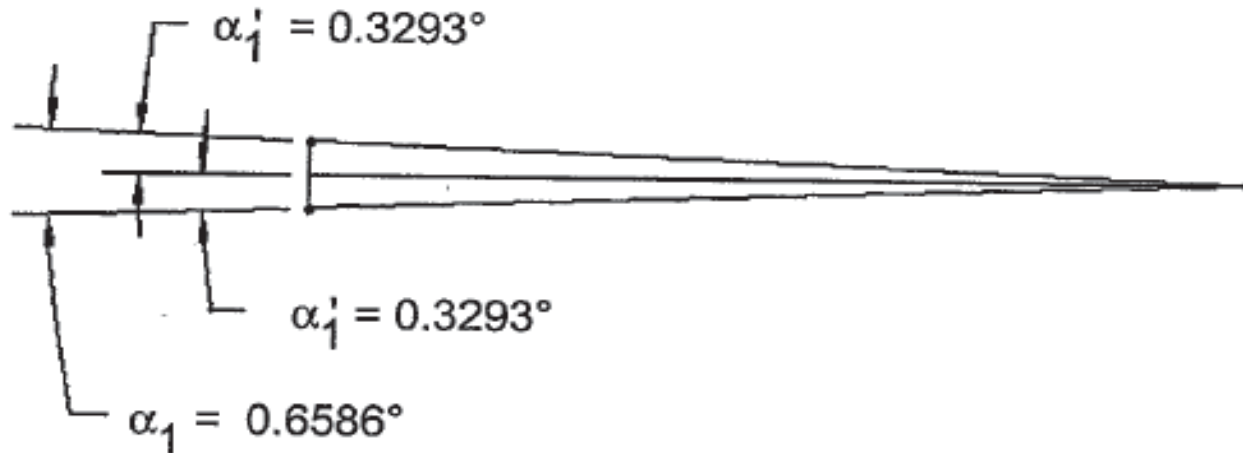

Worst-case Angle from the  $\pm$  Location Tolerances on Holes and Pins

**FIGURE 15.27** Rotation of parts: worst-case angle from  $\pm$  location tolerances, far apart.

### Rotation Of Parts Within A Linear Tolerance Stack up

Solve for Worst-case Angle from Assembly Shift  $\alpha_2$ :

Given:

$$r_2 = \text{largest hole radius} = \frac{.200 + .020}{2} = \frac{.22}{2} = .11$$

$$r_1 = \text{smallest pin radius} = \frac{.150 - .005}{2} = \frac{.145}{2} = .0725$$

$$d_1 = \text{center-to-center distance} = 3.48005747 \text{ (from Step 1)}$$

$$r_2 - r_1 = \text{the radial clearance between the largest hole (LMC) and the smallest (LMC) pin}$$

$$\alpha_2 = 2 \sin^{-1} \left( \frac{r_2 - r_1}{d_1} \right) =$$

$$\alpha_2 = 2 \sin^{-1} \left( \frac{.11 - .0725}{3.48005747} \right) =$$

$$\alpha = \alpha_1 + \alpha_2 = 0.6586^\circ + 1.2348^\circ = 1.8934^\circ$$

This is the total angle of rotation.

$$\alpha_2 = 1.2348^\circ$$



### Rotation With Part Features Closer Together

Calculate the Projected Linear Displacement:

$$\alpha = 1.8934^\circ \quad (\text{Angle of Rotation})$$

$$d_2 = 4.27 \quad (\text{Longest Bar})$$

$$y_2 = \text{Projected Linear Displacement}$$

Solve for  $y_2$ :

$$y_2 = d_2 \sin \alpha = 4.27 \sin 1.8934^\circ$$

$$y_2 = .1411$$

$$\pm \text{Equivalent: } .1411 / 2 = \pm .0706$$

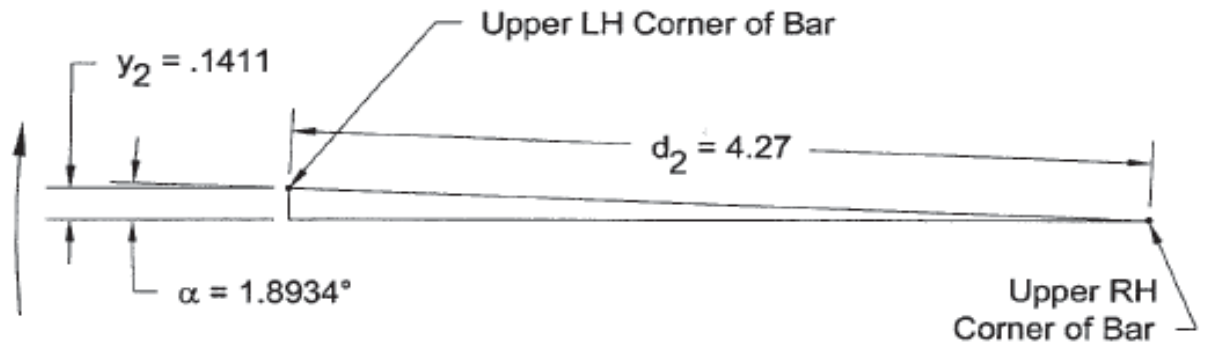

**FIGURE 15.29** Rotation of parts: projected linear displacement, far apart.

Rotation With Part Features Closer Together

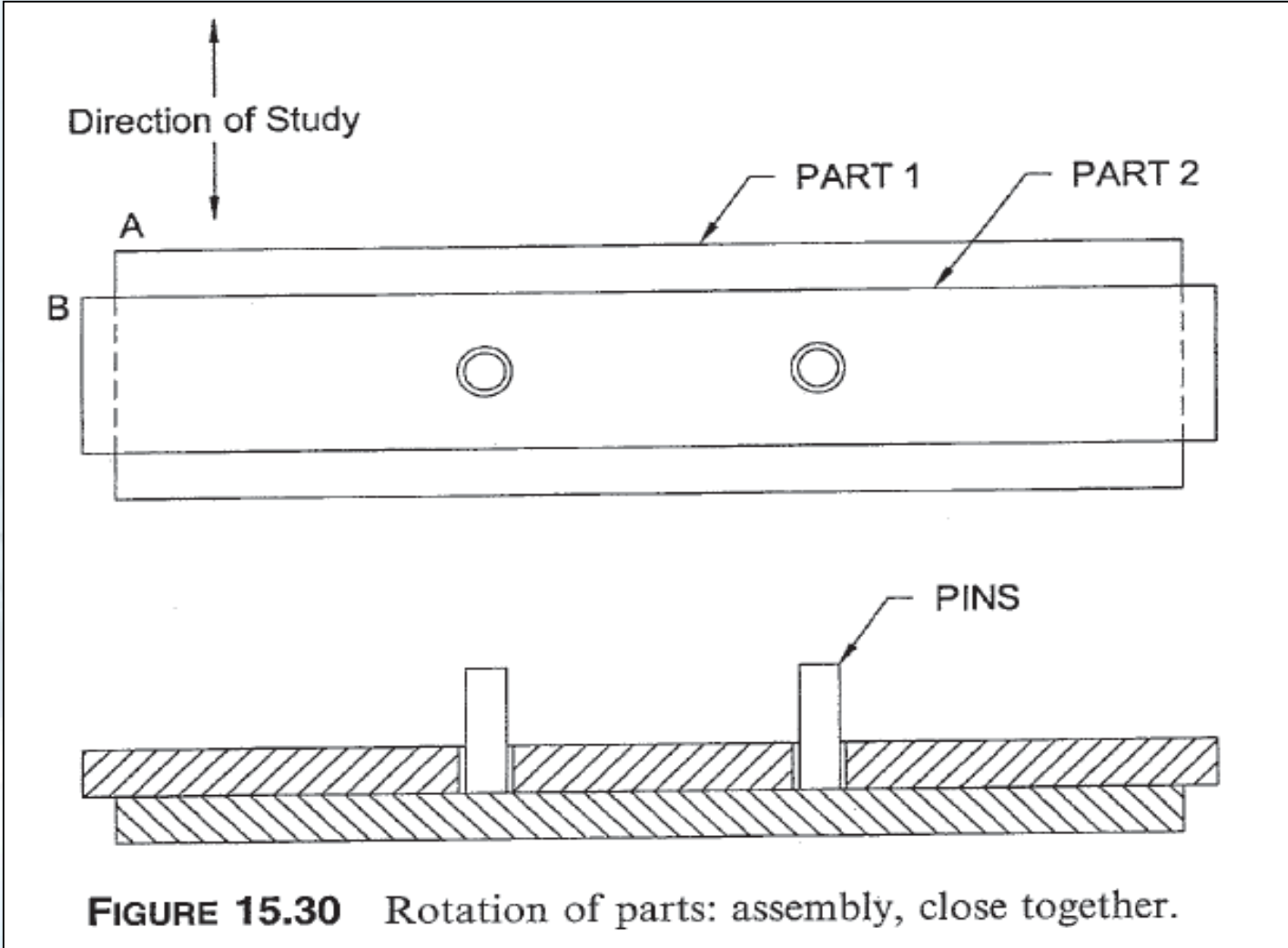

FIGURE 15.30 Rotation of parts: assembly, close together.

Rotation With Part Features Closer Together

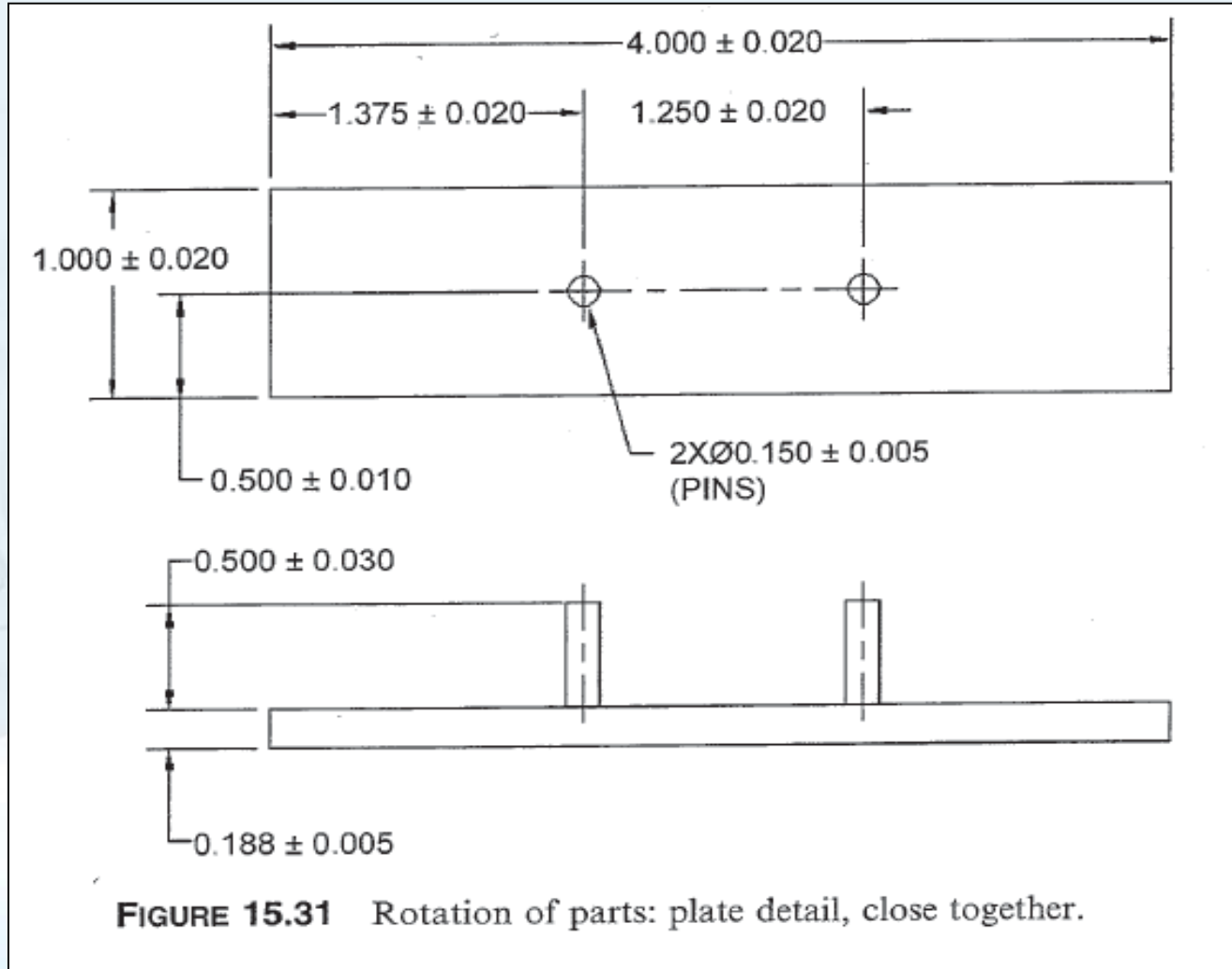
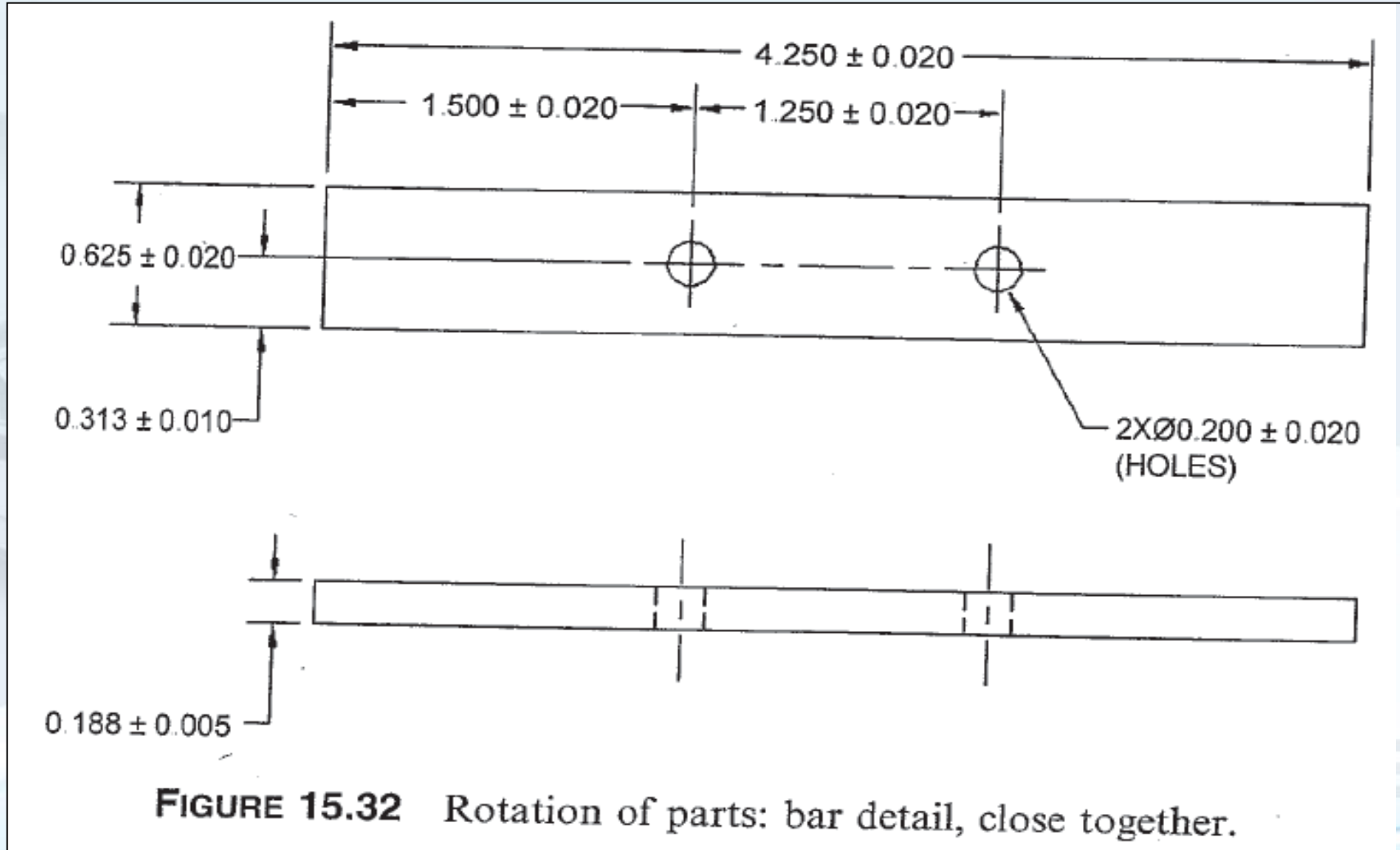
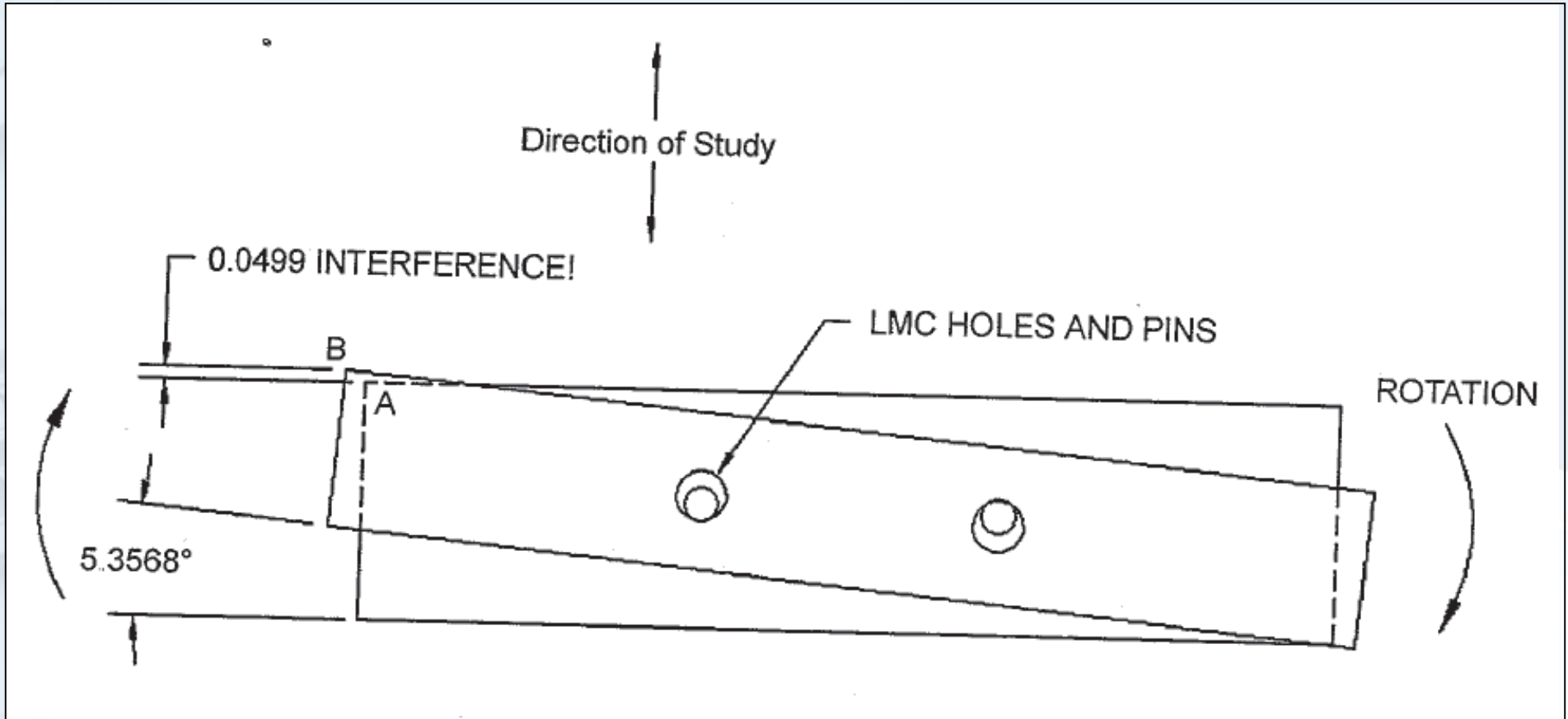

FIGURE 15.31 Rotation of parts: plate detail, close together.

Rotation With Part Features Closer Together



Rotation With Part Features Closer Together



**FIGURE 15.35** Rotation of parts: worst-case assembly translation and rotation, close together.

# Chapter #15 Tolerance Stack-up with Trigonometry

## Rotation With Part Features Closer Together

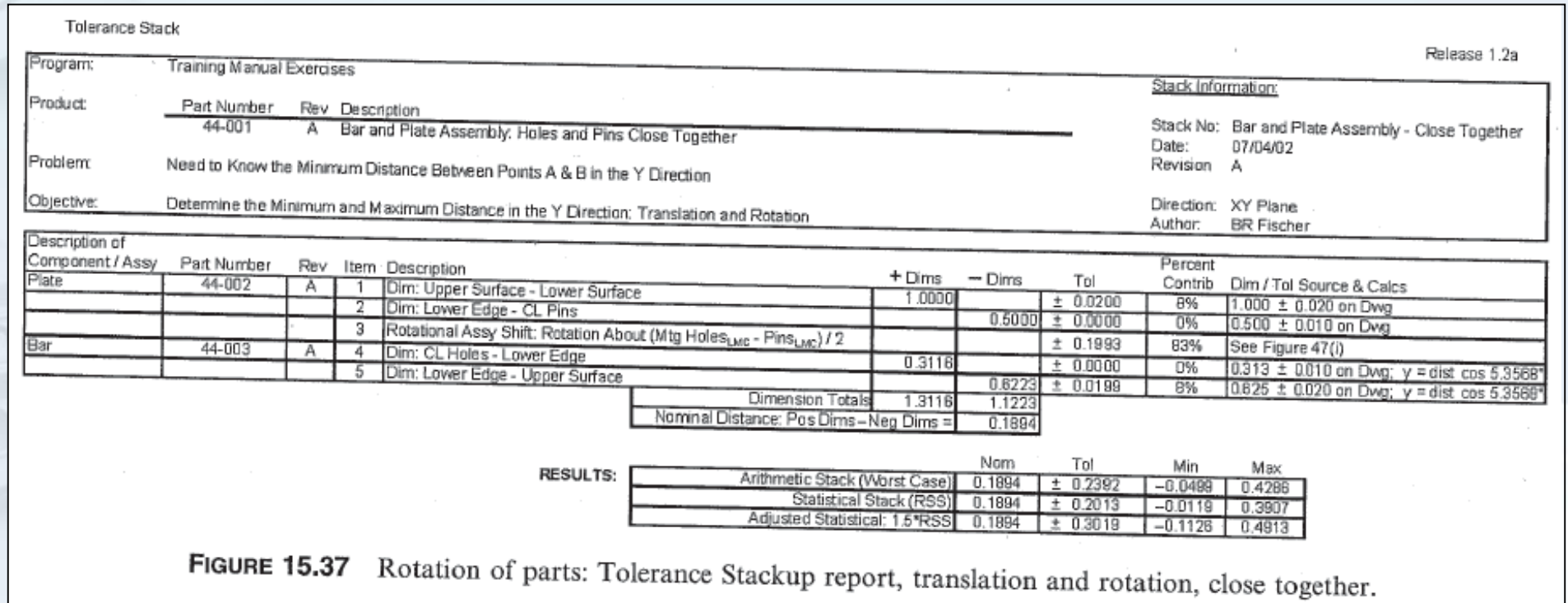



# Chapter #16

QUALITY

## Advanced Tolerance Stack-up



### Advanced Tolerance Stack up Cases

- seven Tolerance Stack up examples based on: mainly GD&T tolerancing and Plus/minus tolerances for FOS.
- Assembly: ground plate is mounted inside an enclosure.
- three optional drawings for the ground plate and three corresponding optional drawings for the enclosure, labeled Options 1,2, and 3.
- Option 1 ground plate is to be used with the Option 1 enclosure,
- Option 2 ground plate is to be used with the Option 2 enclosure,
- Option 3 ground plate is to be used with the Option 3 enclosure.

Advanced Tolerance Stack up Cases

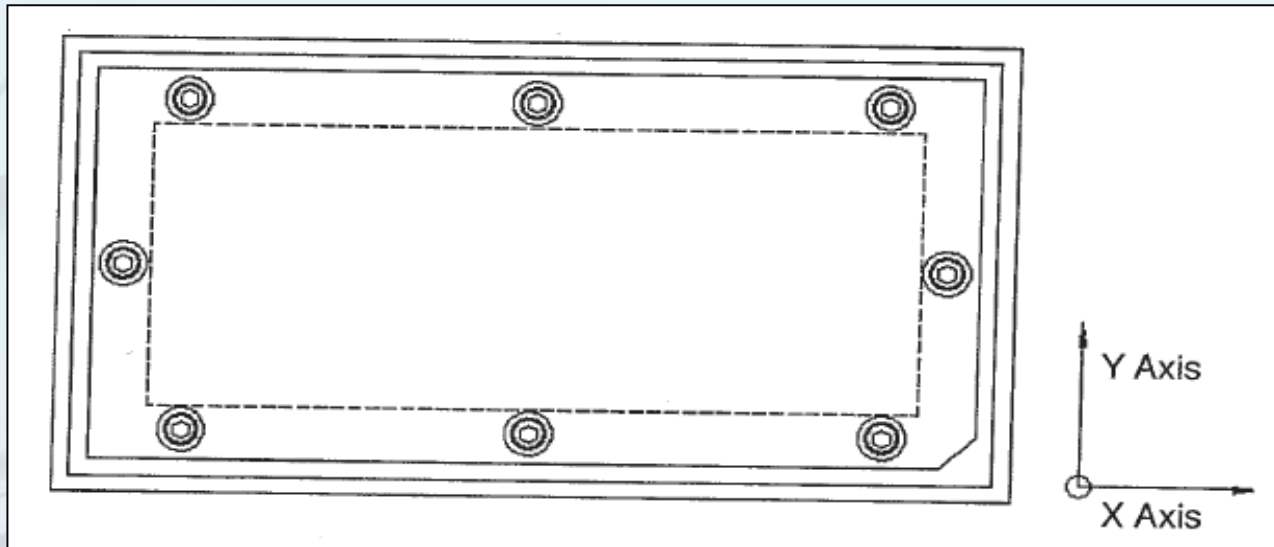
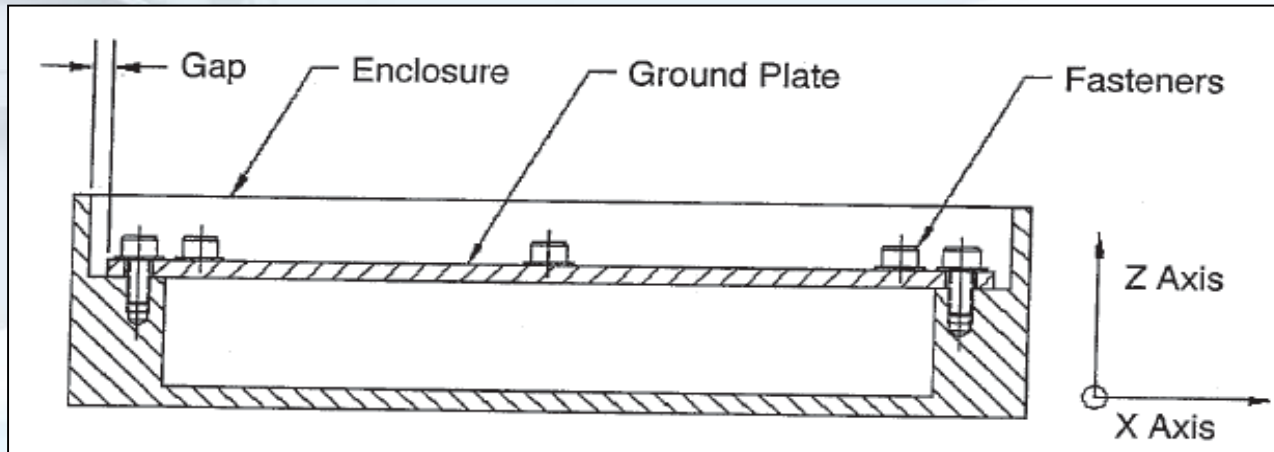

FIGURE 16.1  
Enclosure  
assembly for  
16—18.



Advanced Tolerance Stack up Cases

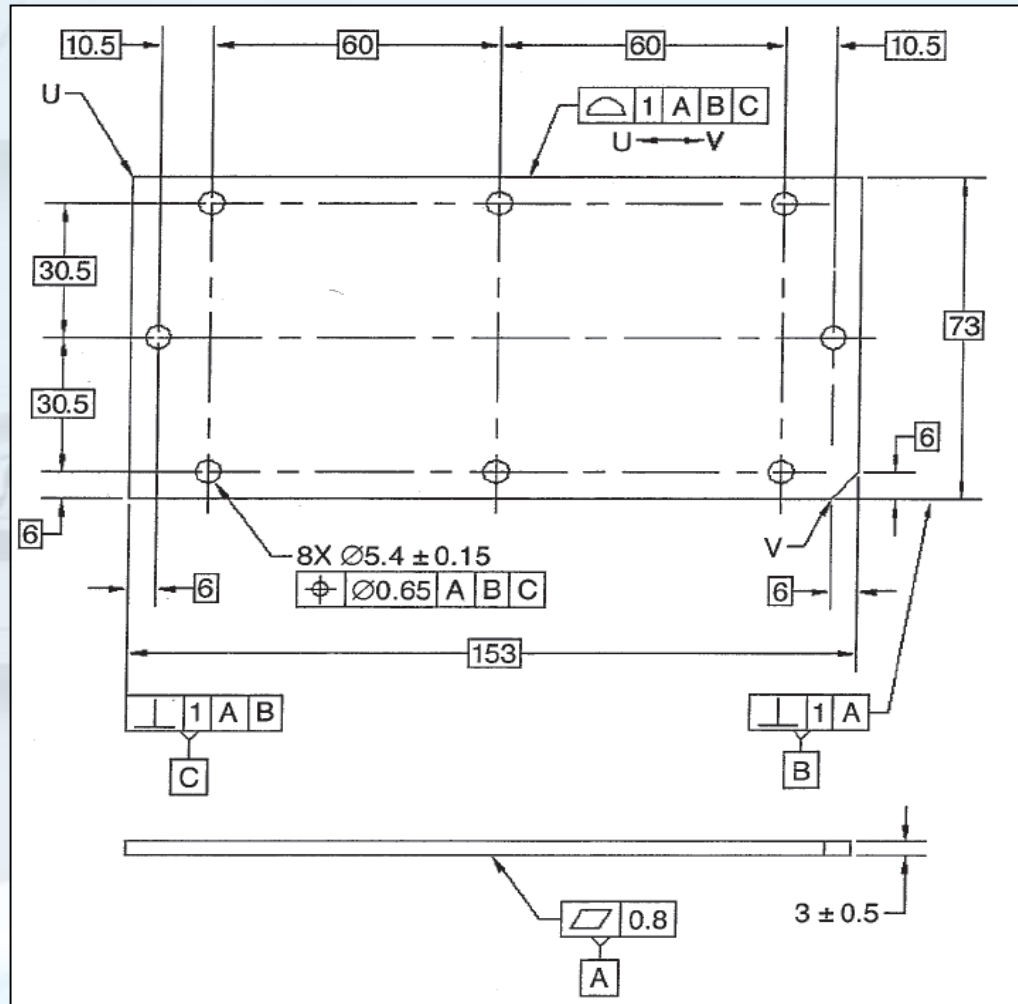

FIGURE 16.2  
Ground plate for  
16–18: Option 1

Advanced Tolerance Stack up Cases

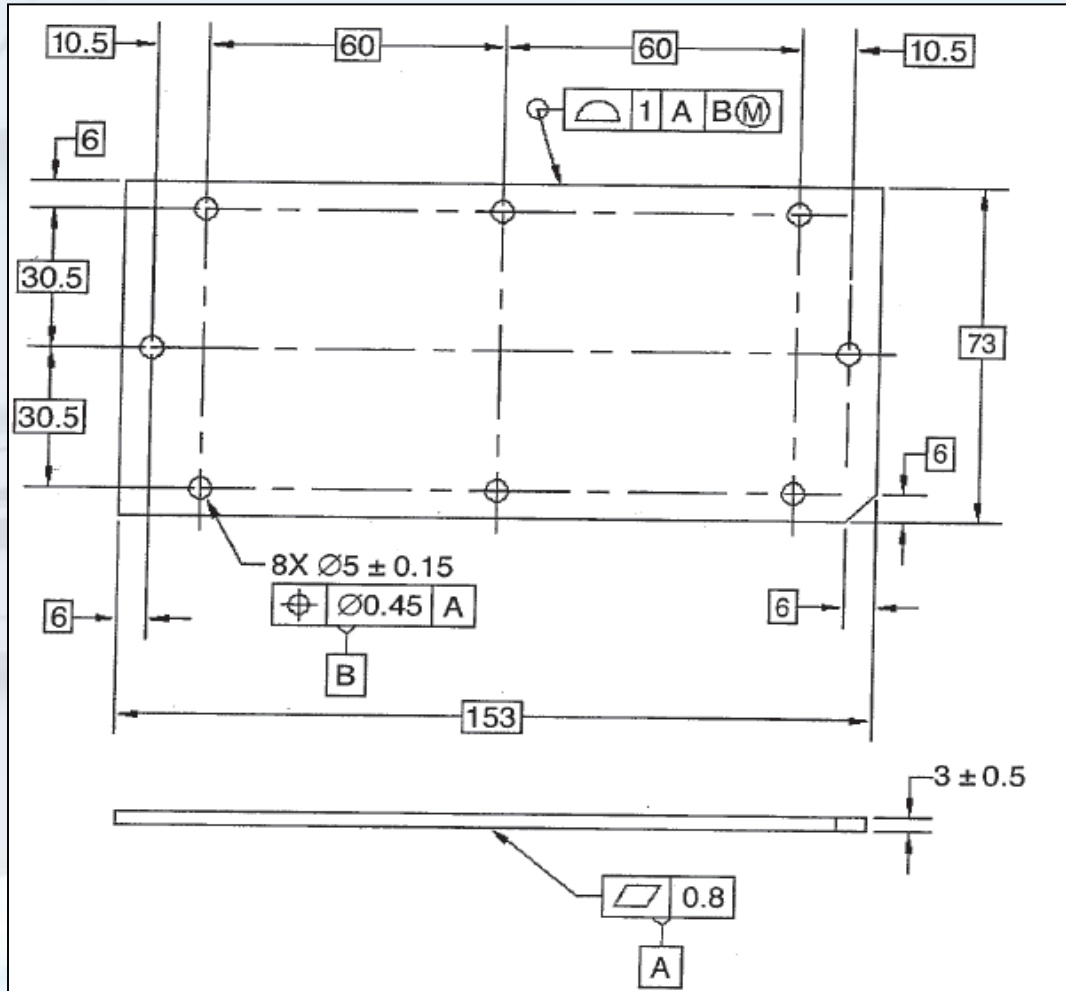

FIGURE 16.3  
Ground plate for  
16—18: Option 2.







Advanced Tolerance Stack up Cases

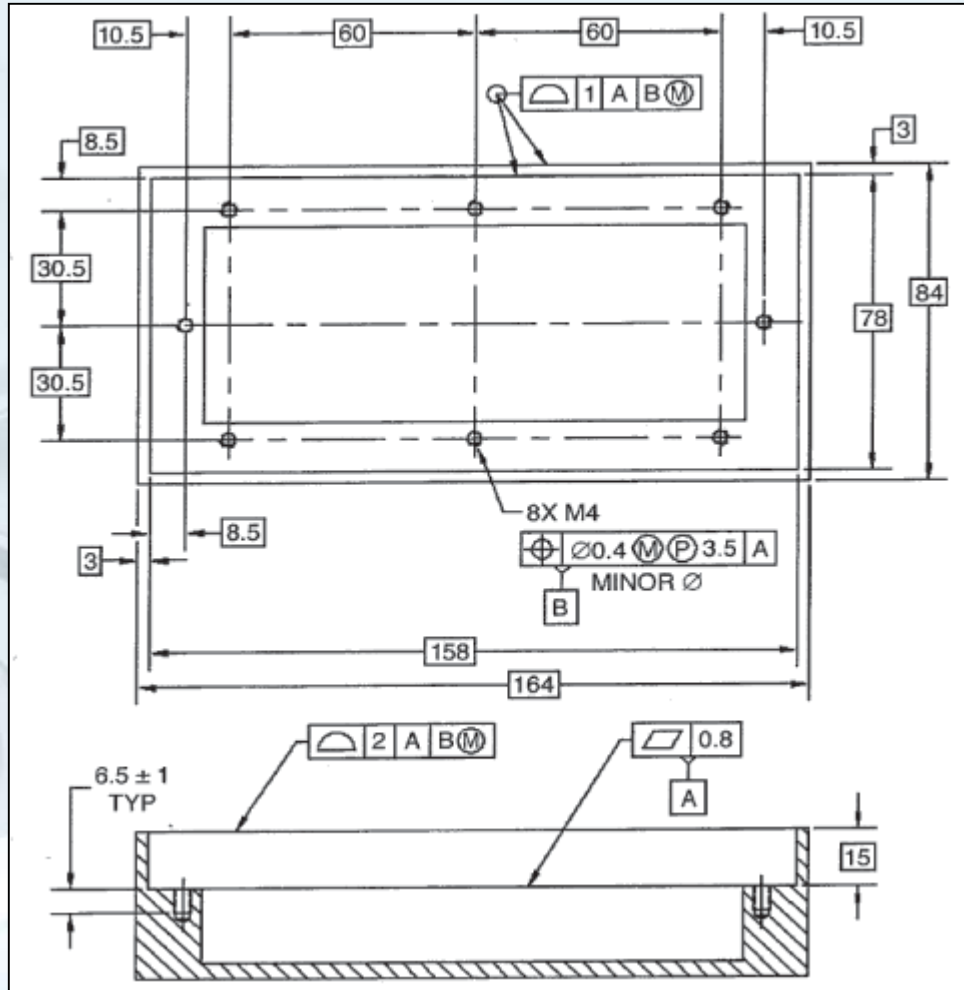

FIGURE 16.6  
Enclosure for 16—  
18: Option 2.

Advanced Tolerance Stack up Cases

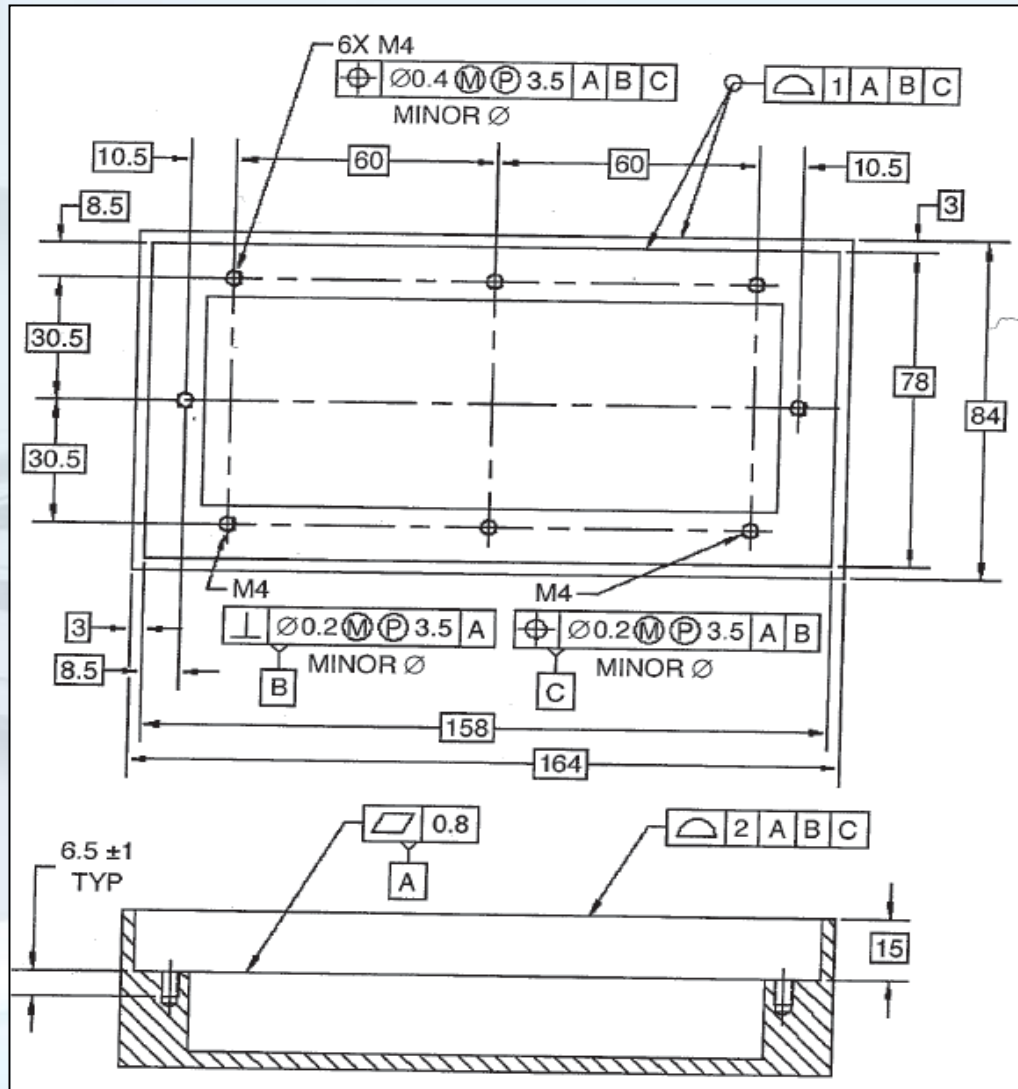
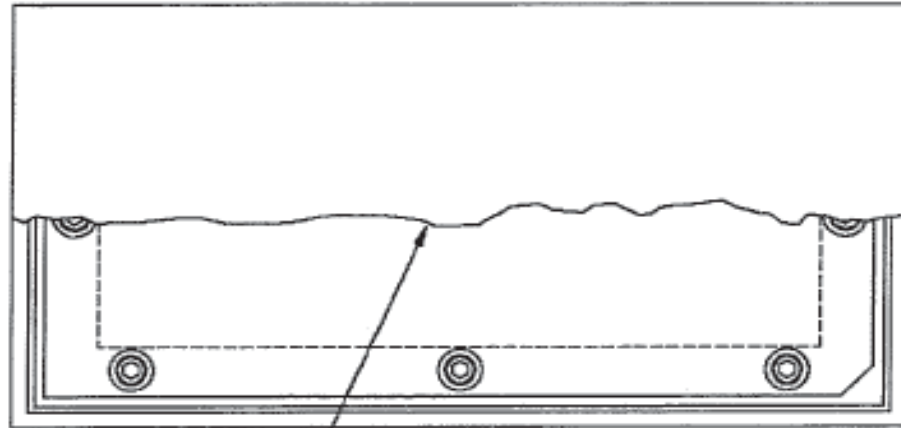
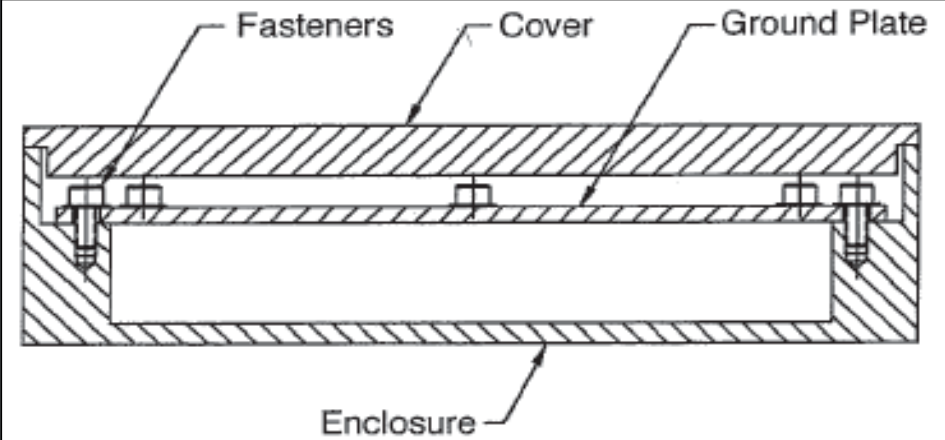

FIGURE 16.7 Enclosure for 16- 18: Option 3.

Advanced Tolerance Stack up Cases



Cover Broken  
Away for Clarity



The Cover must fit within the Enclosure and it must not contact the fasteners.

**FIGURE 16.8** Enclosure assembly with cover.

Advanced Tolerance Stack up Cases

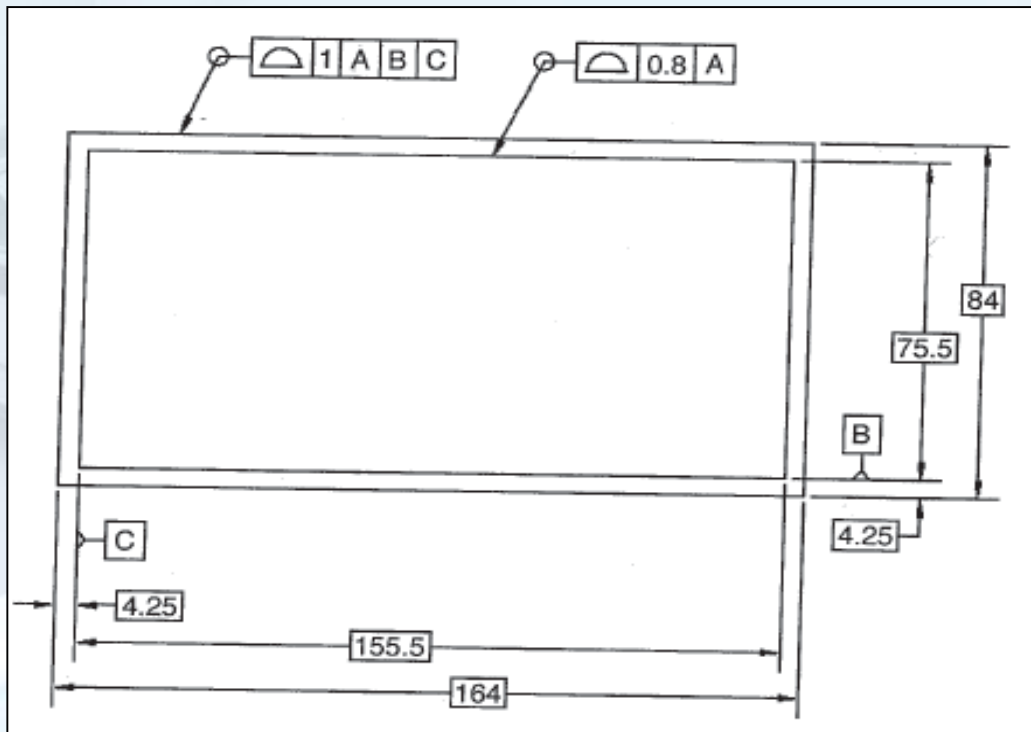
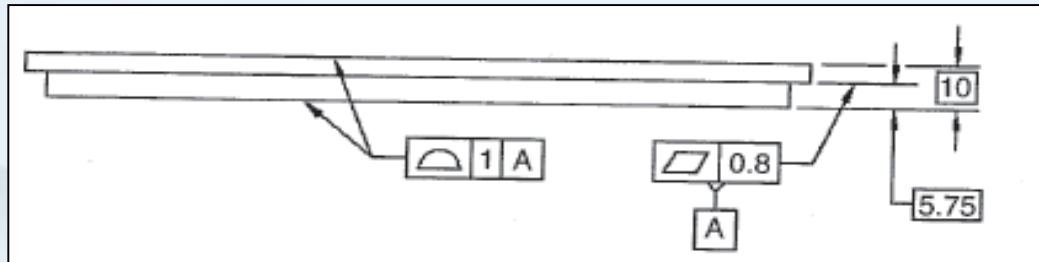
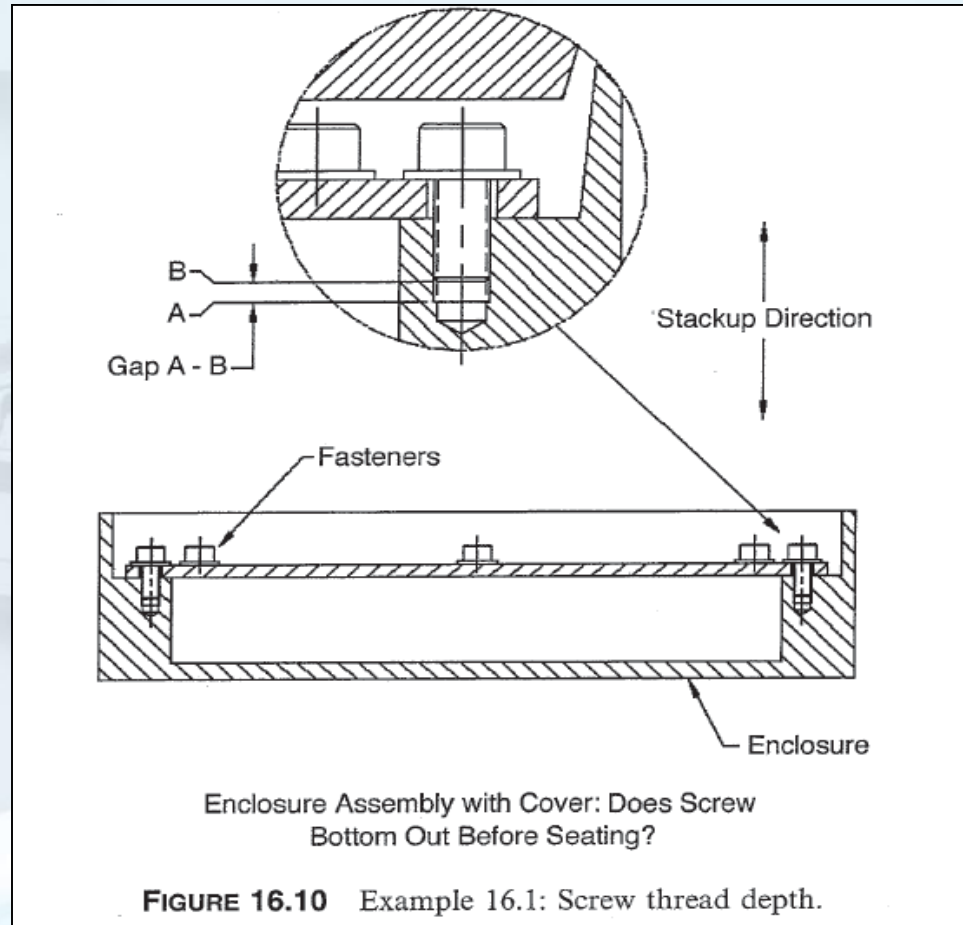

FIGURE 16.9 Cover for 16-18.

### Example 6.1. Screw Thread Depth Tolerance Stack up: Option 1 Determine if the M4 screws bottom out in the threaded holes.



Example 6.1. Screw Thread Depth Tolerance Stack up  
Determine if the M4 screws bottom out in the threaded holes.

Extra data:

- M4 washer thickness =  $1.2 \pm 0.1$ .
- M4 x 8 socket head cap screw length =  $8 \pm 0.2$  (from vendor drawing). Length is from bottom of head to end of screw.



Example 6.1. Screw Thread Depth Tolerance Stack up: Option 1

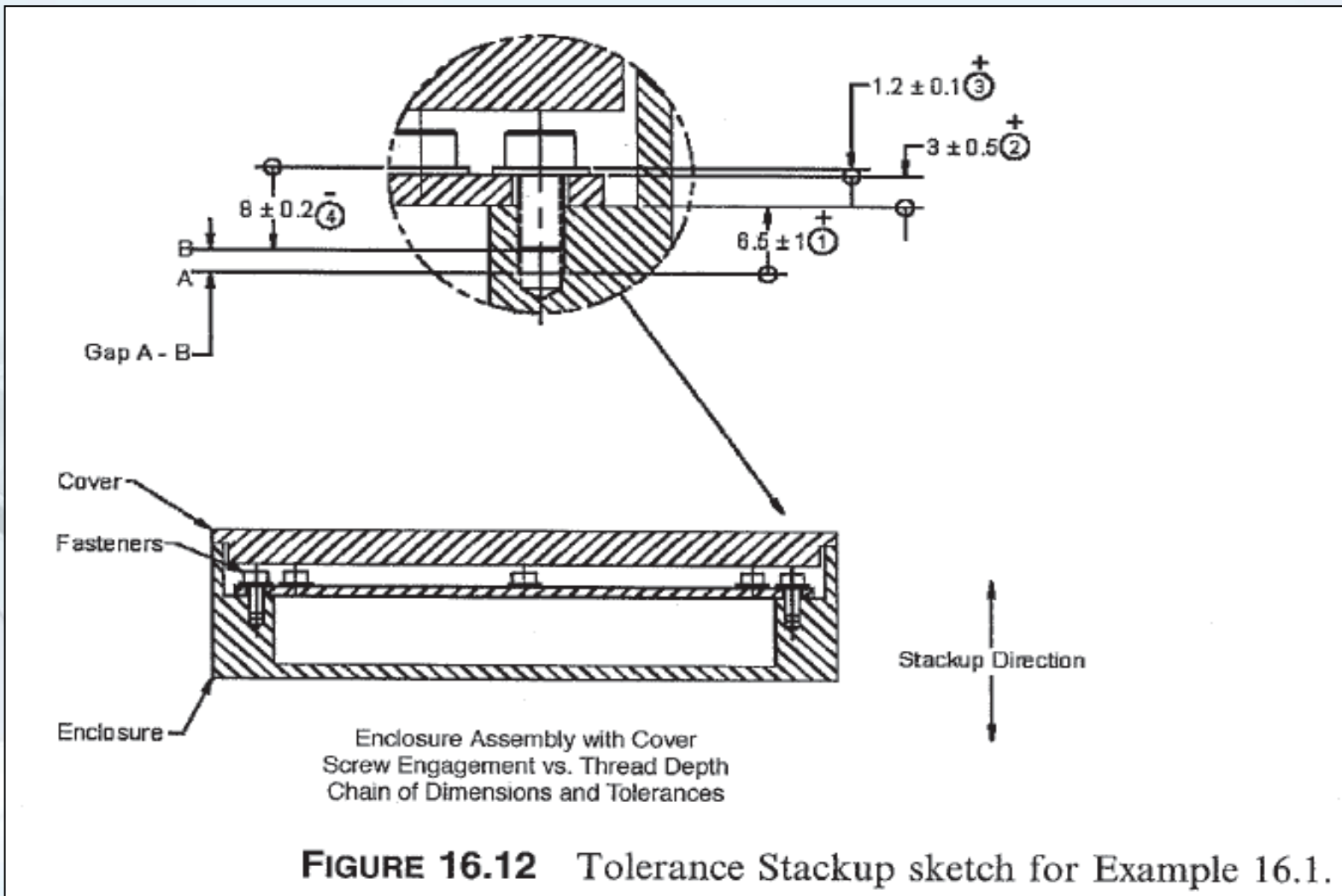

## Chapter #16 Advanced Tolerance Stack-up

### Example 6.1. Screw Thread Depth Tolerance Stack up: Option 1

Tolerance Stack								Release 1.2a	
Program: Electronics Packaging Program AV-11						Stack Information:			
Product: Part Number Rev Description 12345678-001 A Ground Plate Enclosure Assembly						Stack No: Example 16-1			
Problem: Screws Must Not Bottom Out in Tapped Holes						Date: 07/04/02			
Objective: Determine if the M4 Holes in the Enclosure are Deep Enough						Revision: A			
						Direction: Z Axis			
						Author: BR Fischer			
Description of Component / Assy	Part Number	Rev	Item	Description	+ Dims	- Dims	Tol	Percent Contrib	Dim / Tol Source & Calcs
Enclosure	12345678-002	A	1	Dim: Bottom M4 Tapped Hole - DF <sub>A</sub>	6.5000		+/- 1.0000	56%	6.5 +/-1 on Dwg
Ground Plate	12345678-004	A	2	Dim: Bottom Surface - Top Surface	3.0000		+/- 0.5000	28%	3 +/- 0.5 on Dwg
M4 Washer			3	Dim: Bottom Surface - Top Surface	1.2000		+/- 0.1000	6%	1.2 +/- 0.1 fm Machinery's Hdbk 23rd Ed.
M4 X 8 SHCS			4	Dim: Underside of Head - End of Screw		8.0000	+/- 0.2000	11%	8 +/-0.2 fm Vendor Dwg
Dimension Totals					10.7000	8.0000			
Nominal Distance: Pos Dims - Neg Dims =					2.7000				
<b>RESULTS:</b>					Nom	Tol	Min	Max	
Arithmetic Stack (Worst Case)					2.7000	+/- 1.8000	0.9000	4.5000	
Statistical Stack (RSS)					2.7000	+/- 1.1402	1.5598	3.8402	
Adjusted Statistical: 1.5*RSS					2.7000	+/- 1.7103	0.9697	4.4103	
Notes:									
Assumptions: - Used Enclosure and Ground Plate Option 1 for this study.									
Suggested Action:									

FIGURE 16.11 Tolerance Stackup report for Example 16.1.

**Example 16.2. Cover Fit Tolerance Stack up Along X Axis: Option 2**  
**Determine if the cover fits within the enclosure along X axis.**

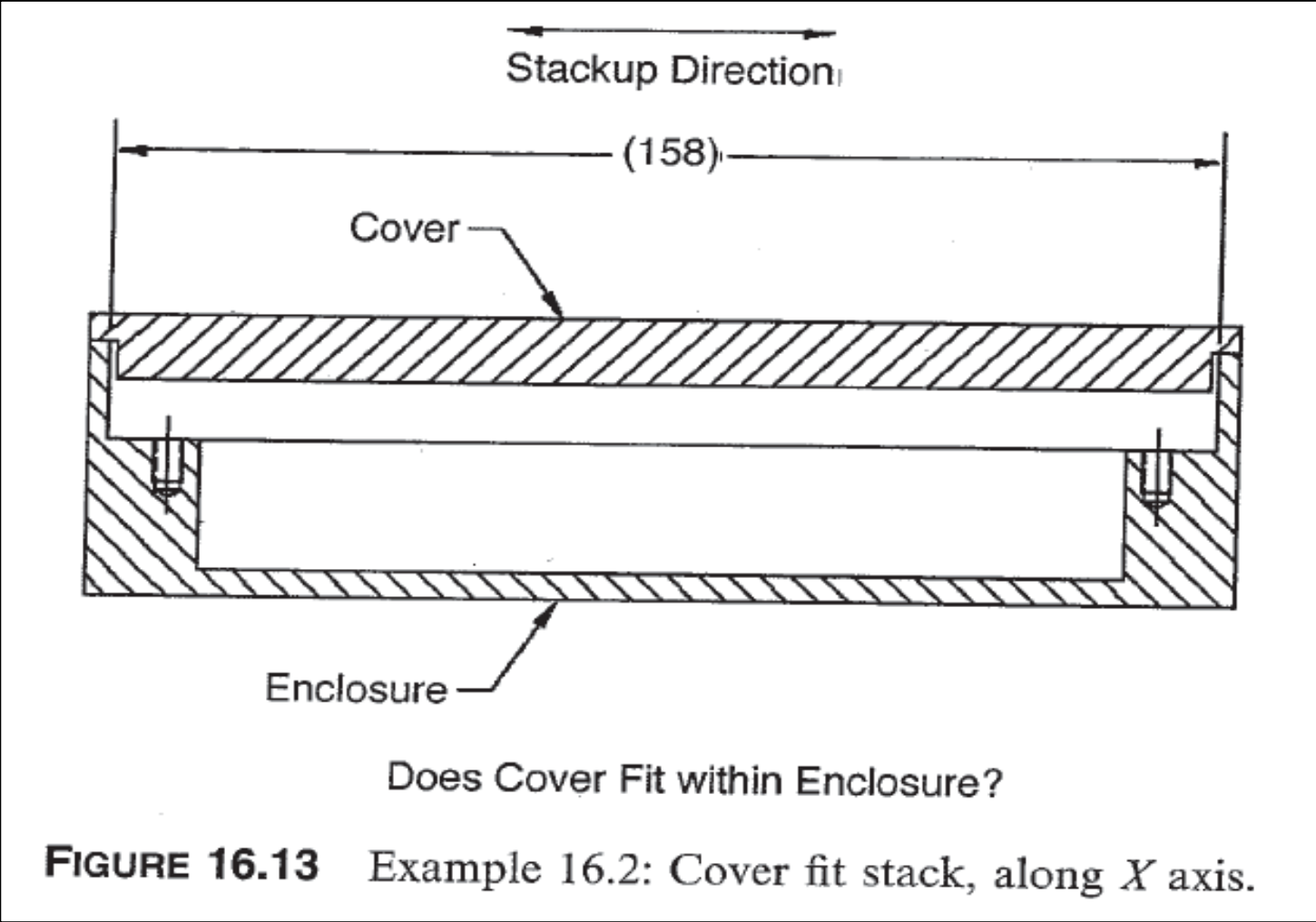

# Chapter #16 Advanced Tolerance Stack-up

## Example 16.2. Cover Fit Tolerance Stack up Along X Axis : Option 2

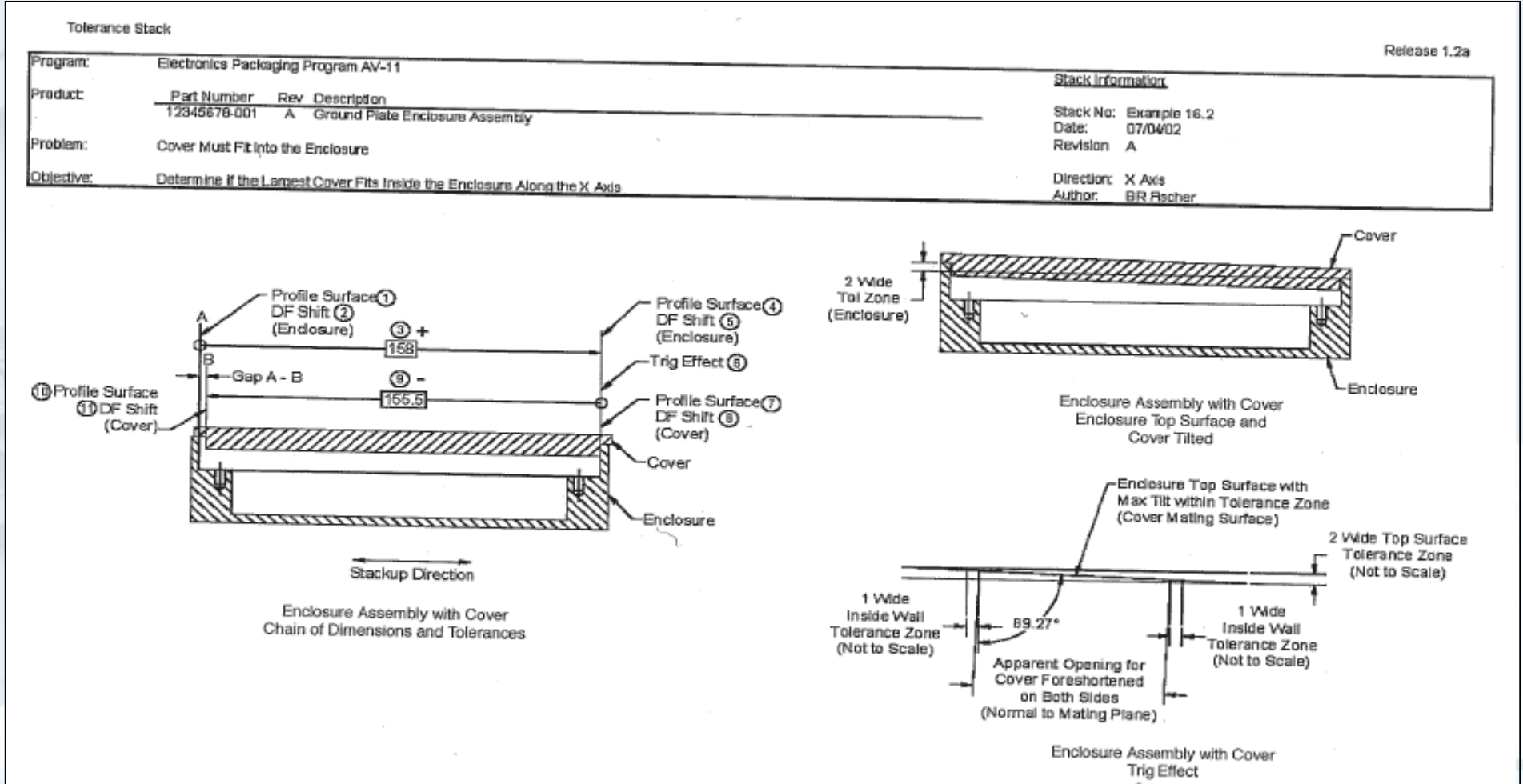

Example 16.2. Cover Fit Tolerance Stack up Along X Axis : Option 2

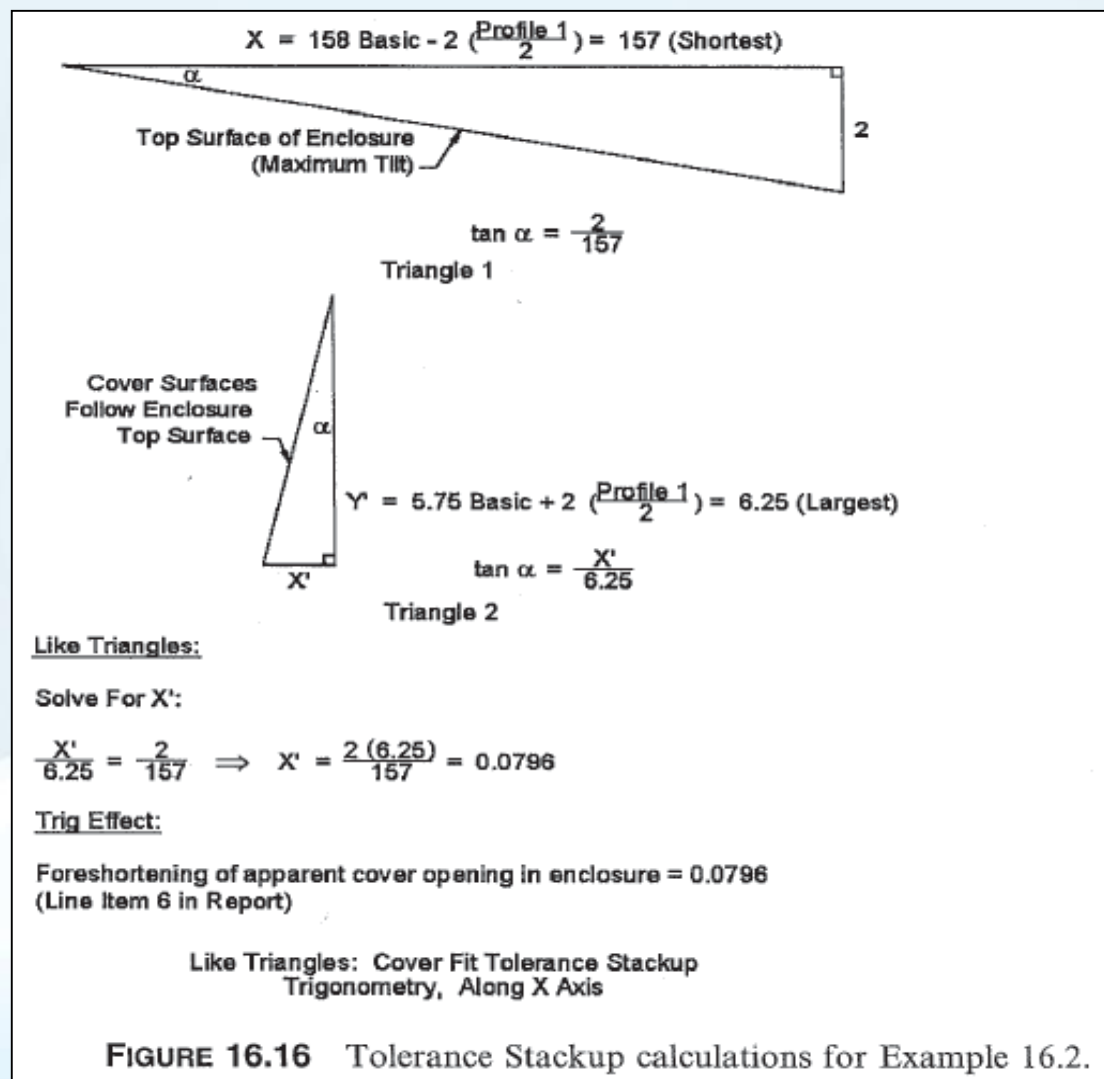



# Chapter #16 Advanced Tolerance Stack-up

## Example 16.2. Cover Fit Tolerance Stack up Along X Axis : Option 2

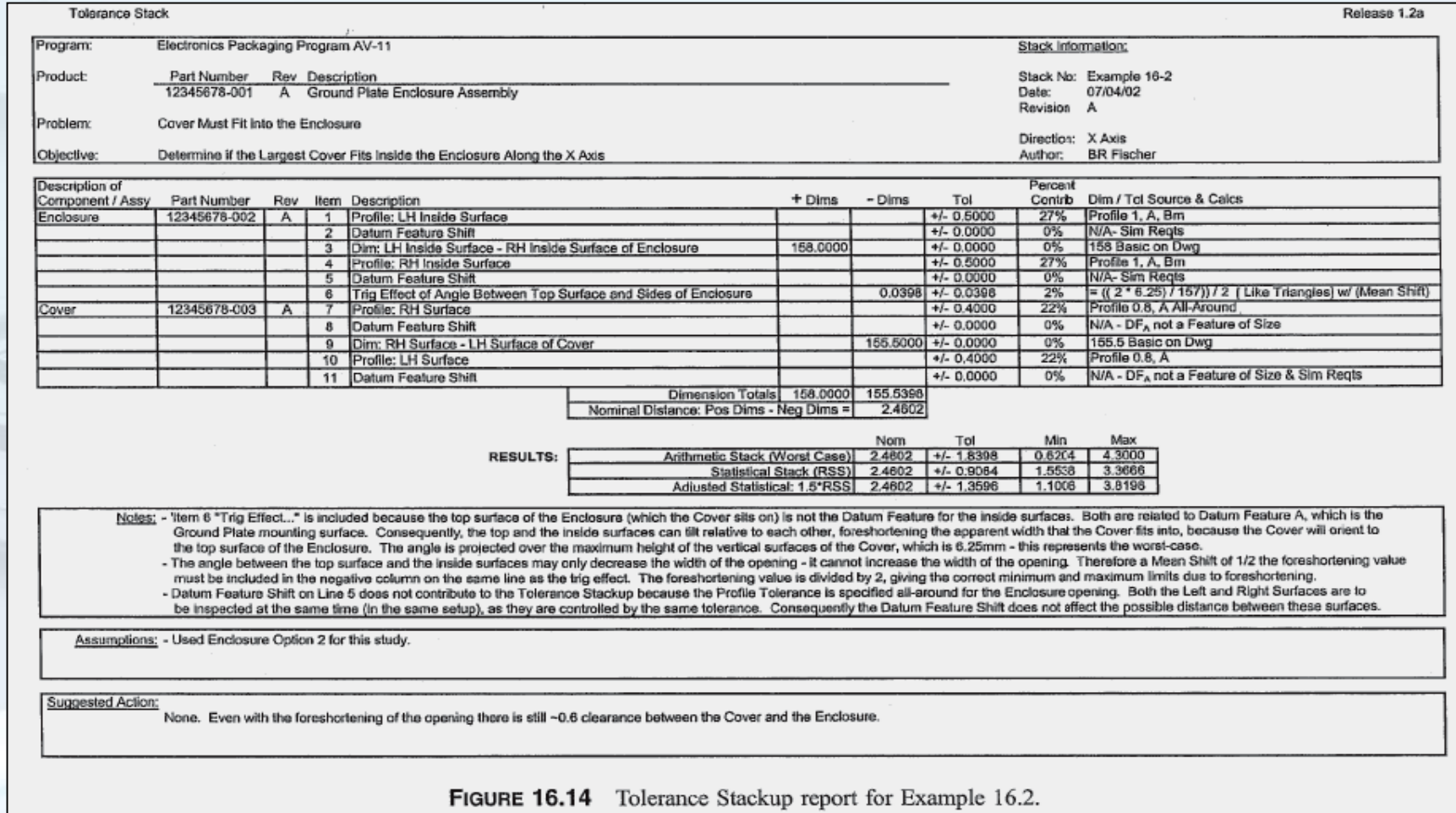
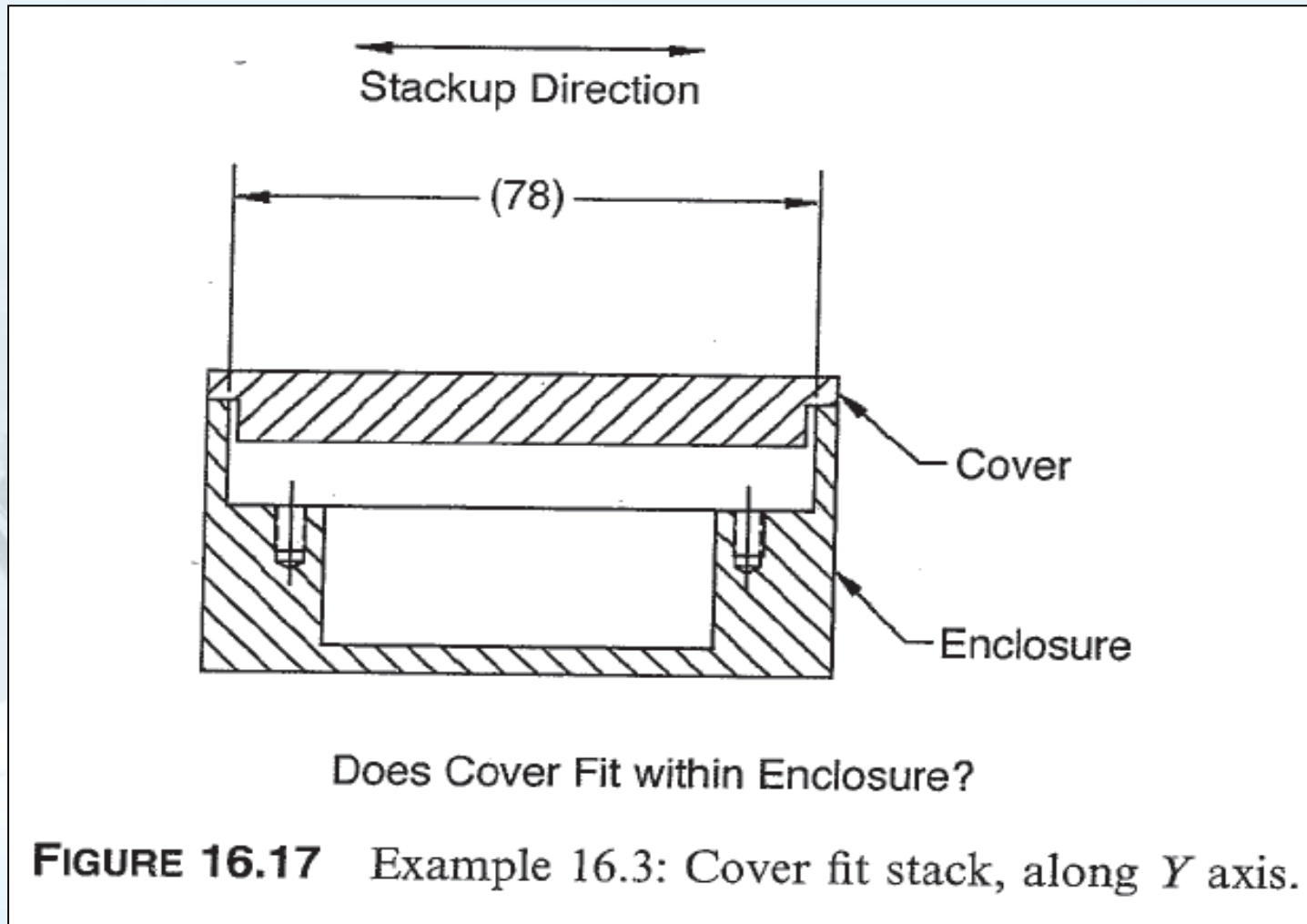

FIGURE 16.14 Tolerance Stackup report for Example 16.2.



**Example 16.3. Cover Fit Tolerance Stack up Along the Y Axis: : Option 2**  
**Determine if the cover fits within the enclosure along Y axis.**



Example 16.3. Cover Fit Tolerance Stack up Along the Y Axis: : Option 2

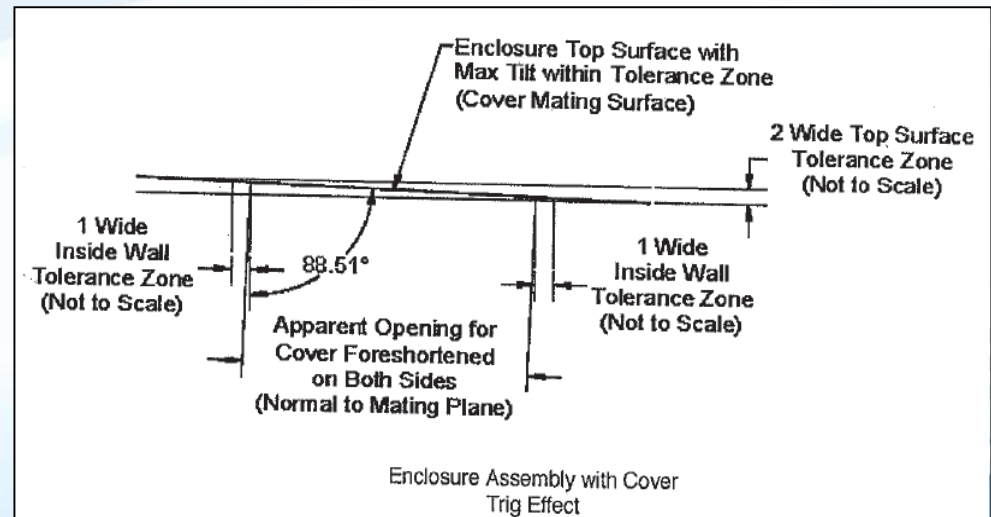
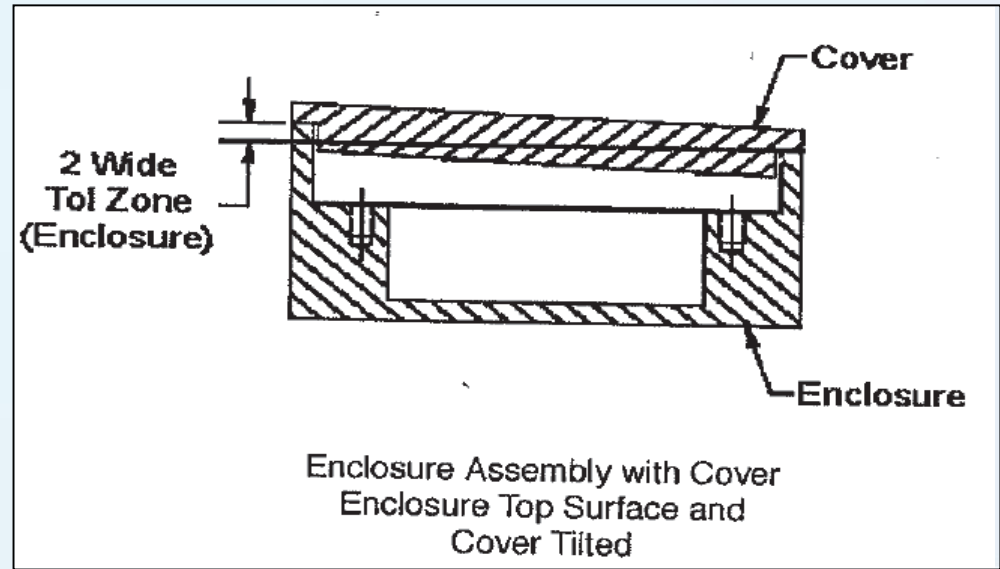
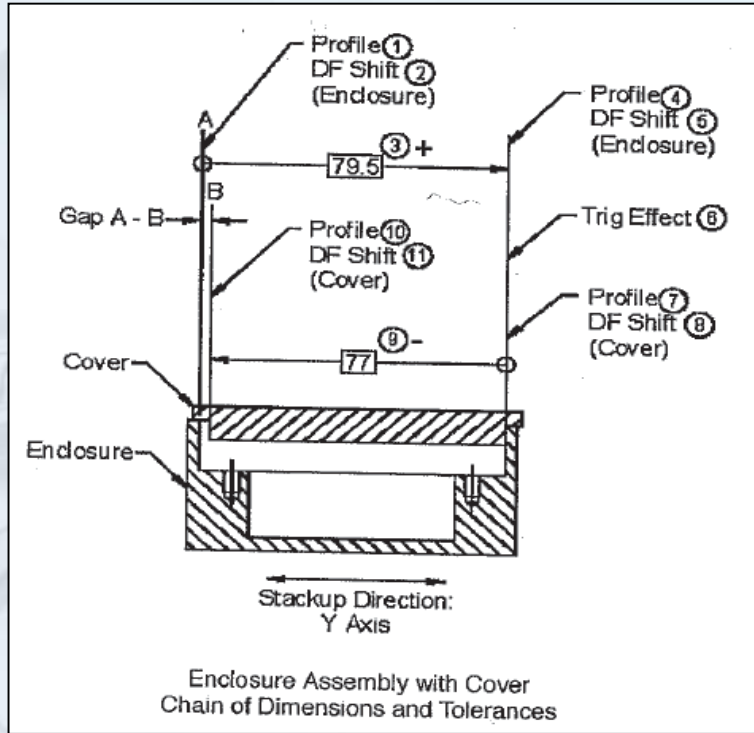

Example 16.3. Cover Fit Tolerance Stack up Along the Y Axis: : Option 2

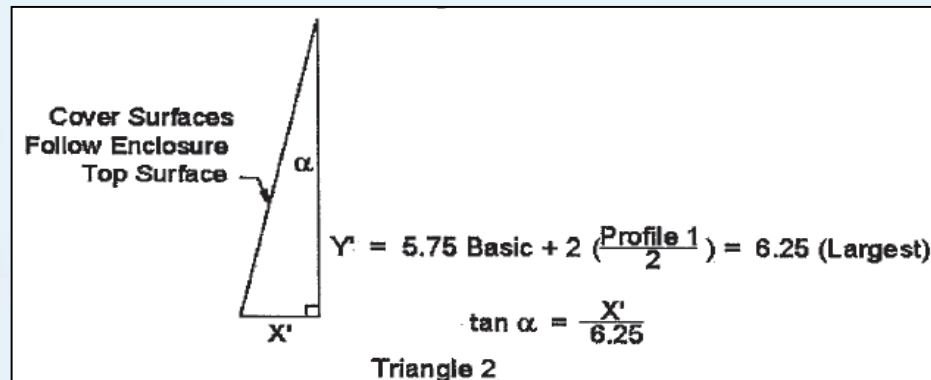
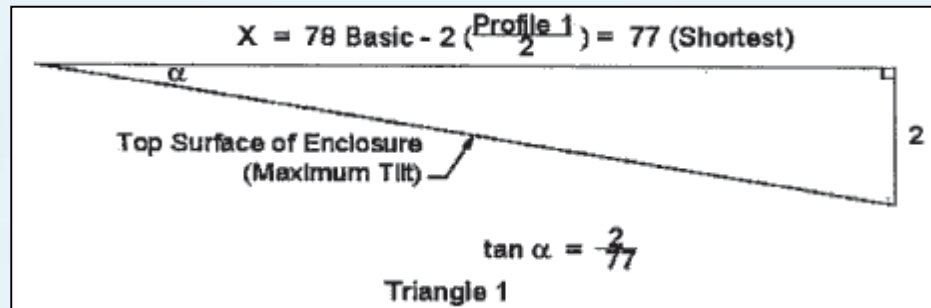

Like Triangles:

Solve For X':

$$\frac{X'}{6.25} = \frac{2}{77} \Rightarrow X' = 2 \frac{6.25}{77} = 0.1623$$

Trig Effect:

Foreshortening of apparent cover opening in enclosure = 0.1623  
(Line Item 6 in Report)

Example 16.3. Cover Fit Tolerance Stack up Along the Y Axis: : Option 2

Release 1.2a

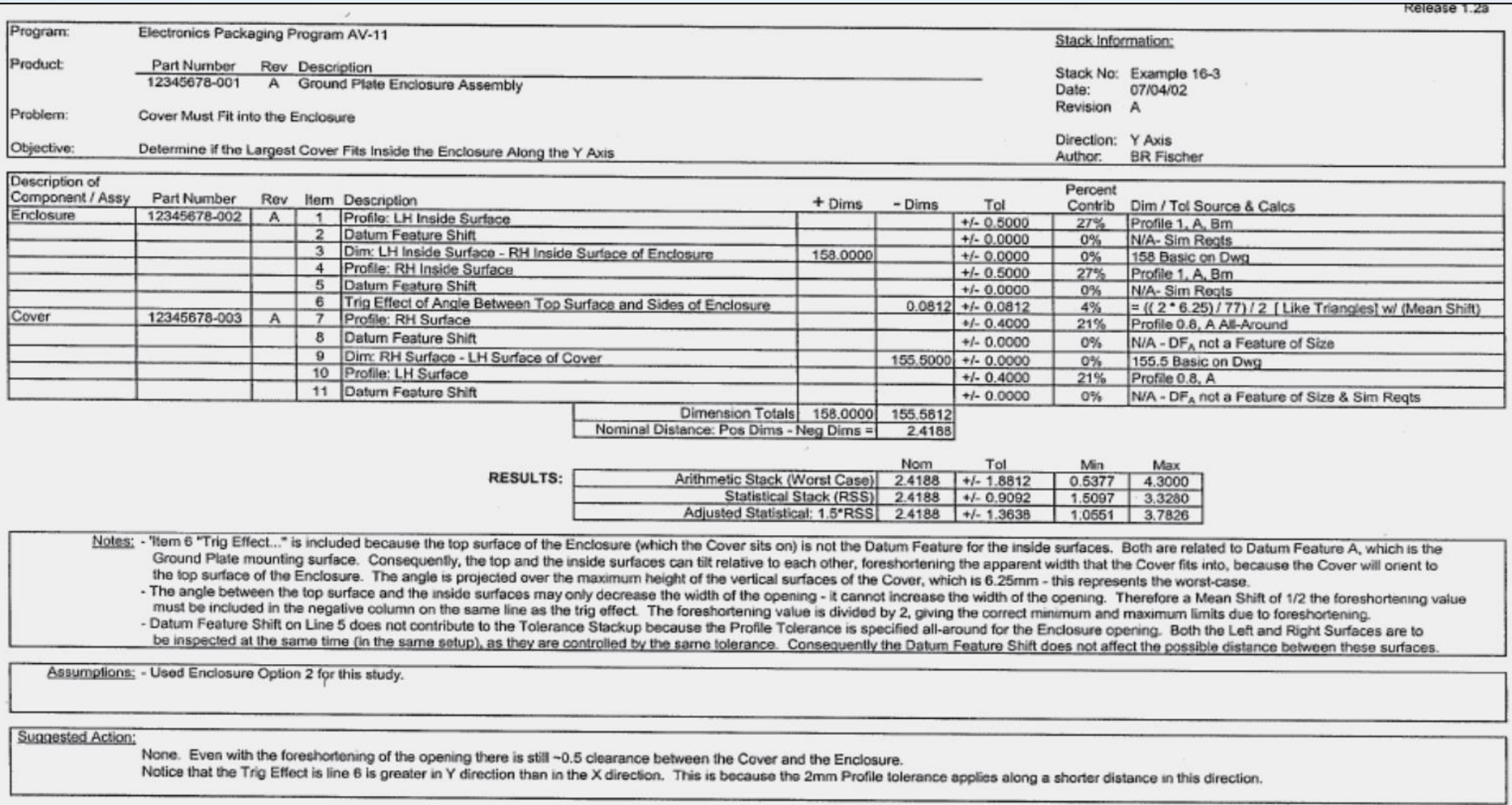
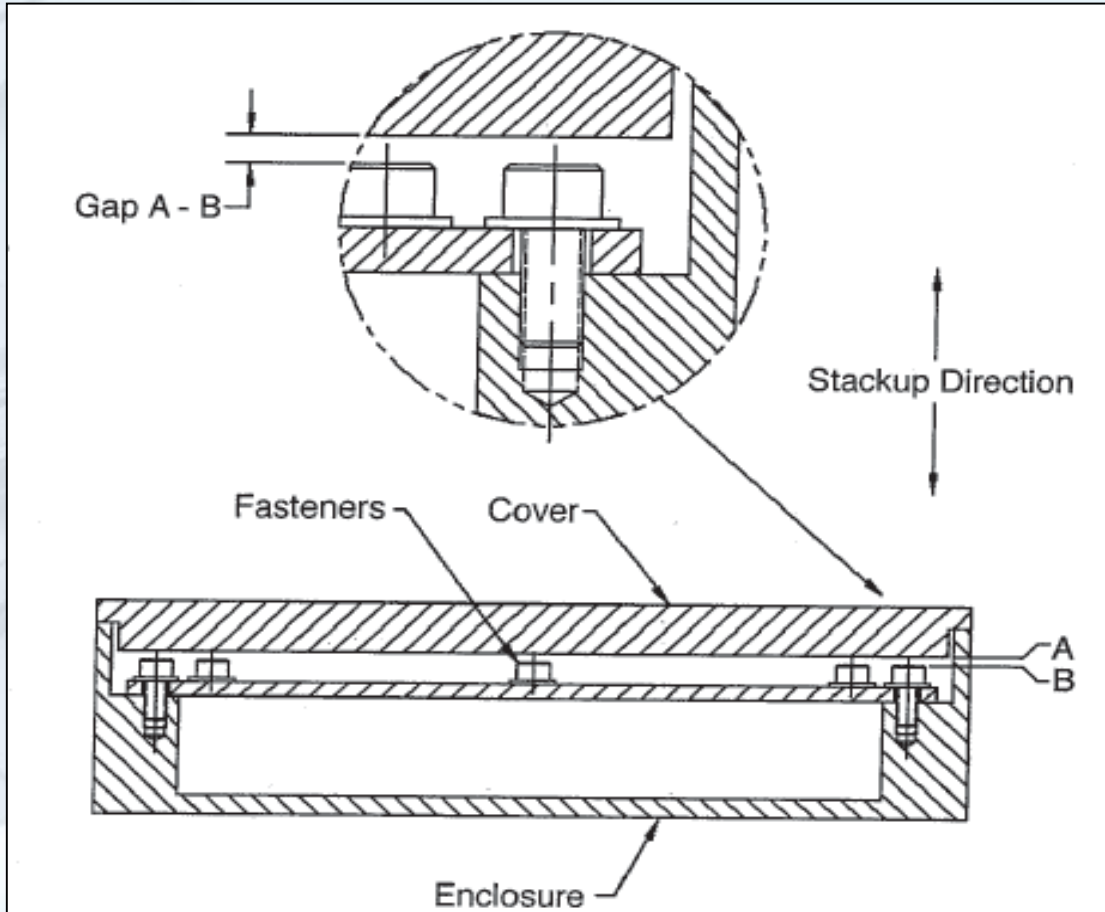

FIGURE 16.18 Tolerance Stackup report for Example 16.3.



### Example 16.4. Screw Head Clearance Tolerance Stack up: Option 1 Determine if the cover contacts the M4 screw heads.



Extra data:

- M4 washer thickness =  $1.2 \pm 0.1$ .
- M4 x 8 screw head height =  $4/3.82$





# Chapter #16 Advanced Tolerance Stack-up

## Example 16.4. Screw Head Clearance Tolerance Stack up: Option 1

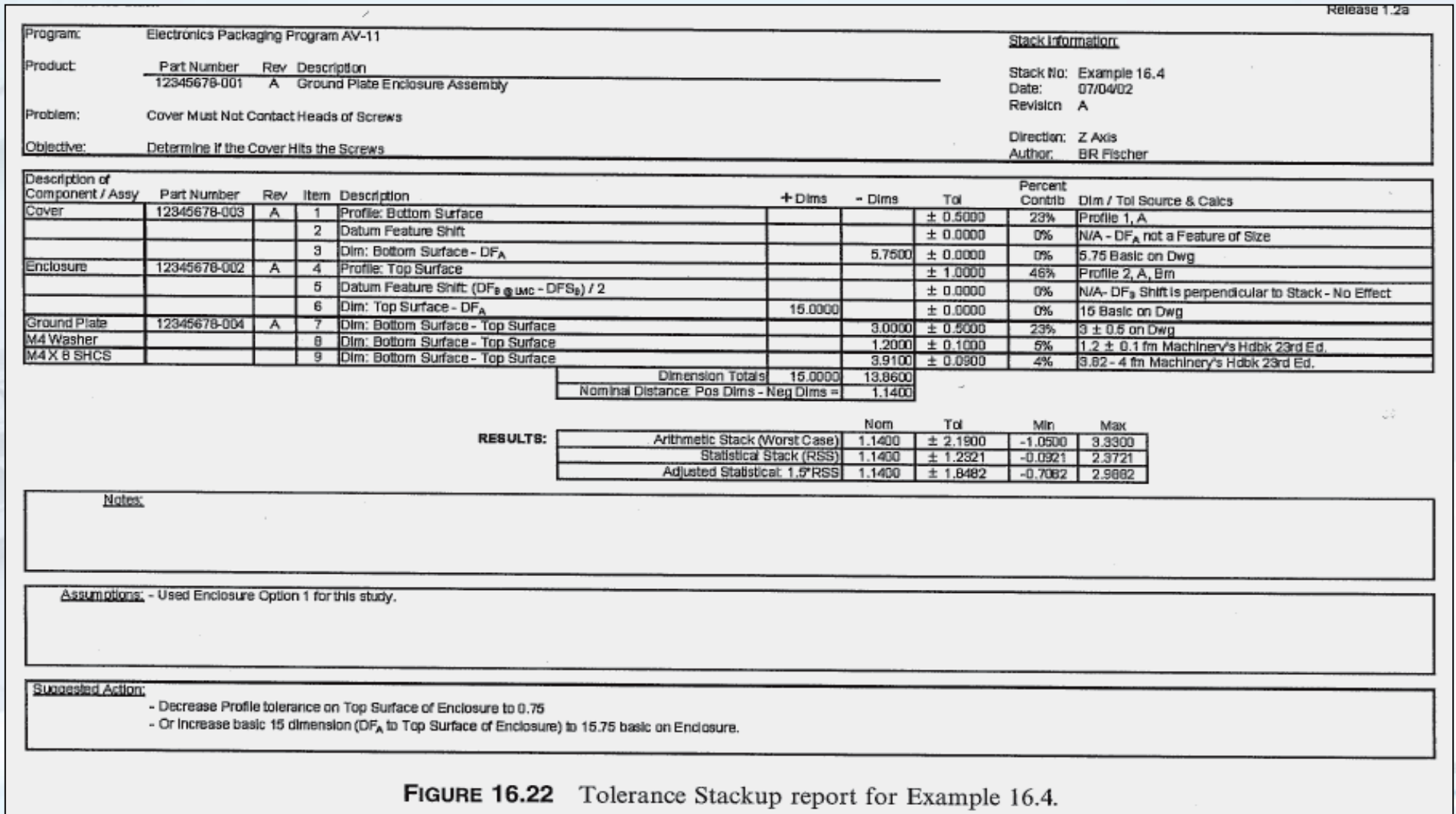
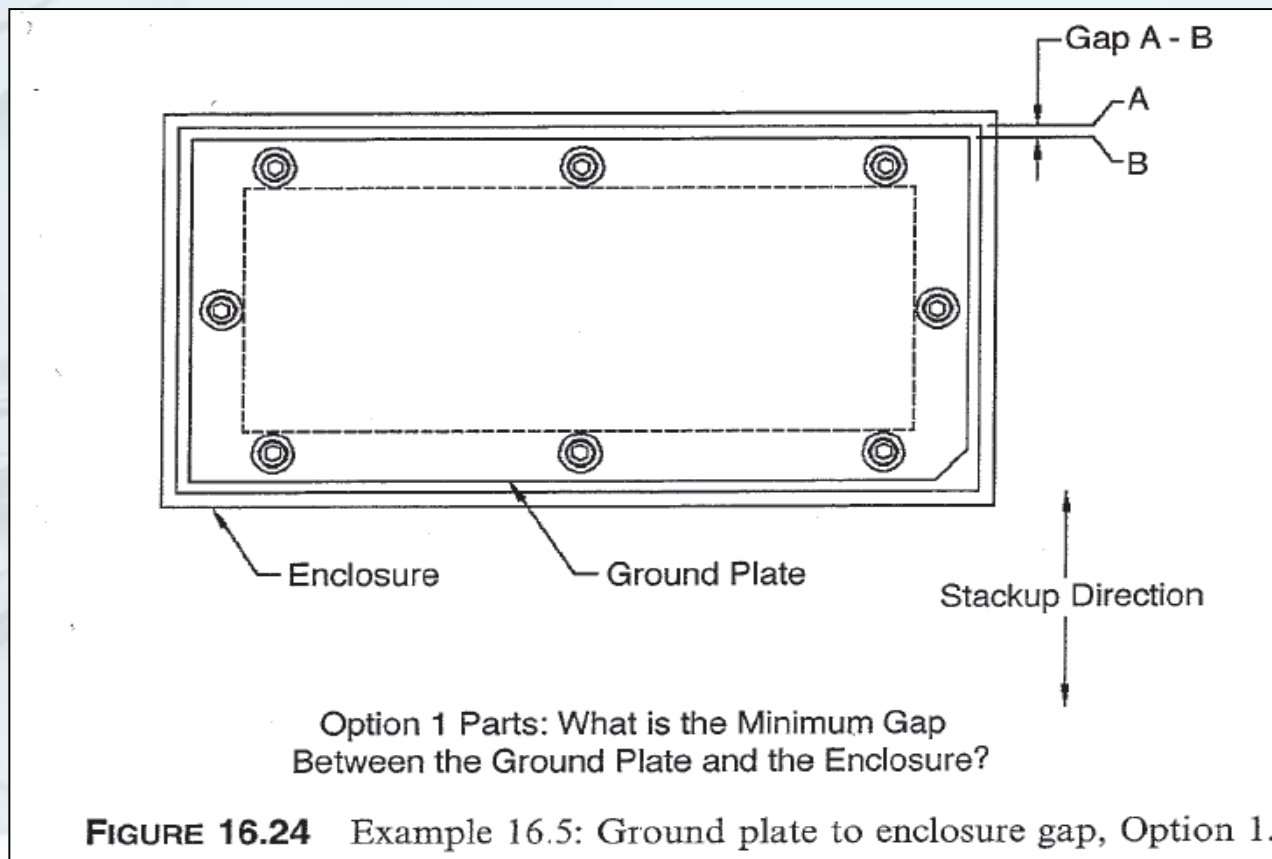

FIGURE 16.22 Tolerance Stackup report for Example 16.4.

**Example 16.5. Ground Plate to Enclosure Gap Study: Option 1 Parts**  
**Determine if the ground plate contacts the inside walls of the enclosure.**



Extra data:

- M4 tapped hole Dims:  
Minor diameter=3.242-3.422.
- M4 x 8 socket head cap screw  
Dims:  
Major diameter 3.82-4.

## Chapter #16 Advanced Tolerance Stack-up

### Example 16.5. Ground Plate to Enclosure Gap Study: Option 1 Parts

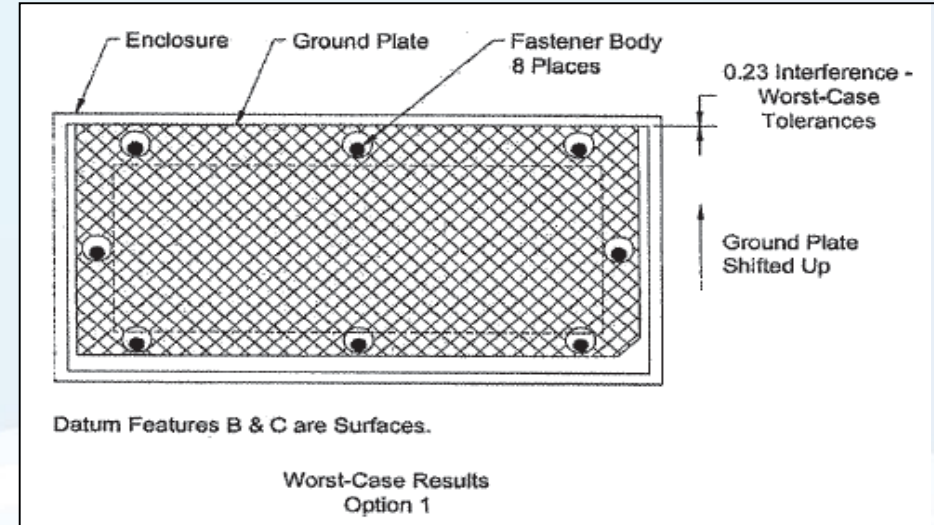
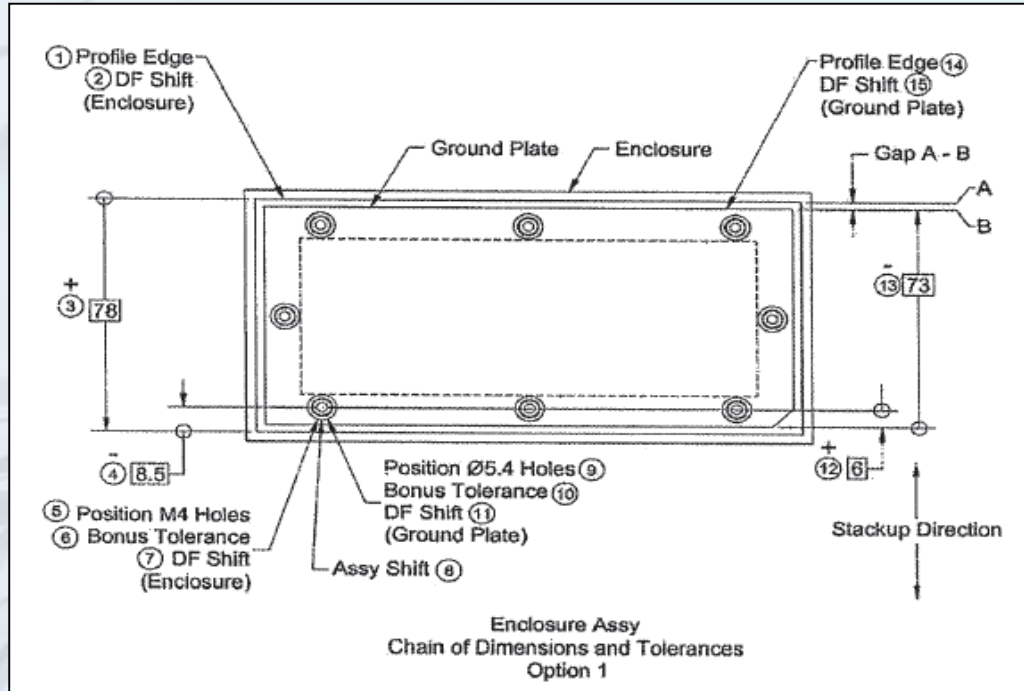

## Example 16.5. Ground Plate to Enclosure Gap Study: Option 1 Parts

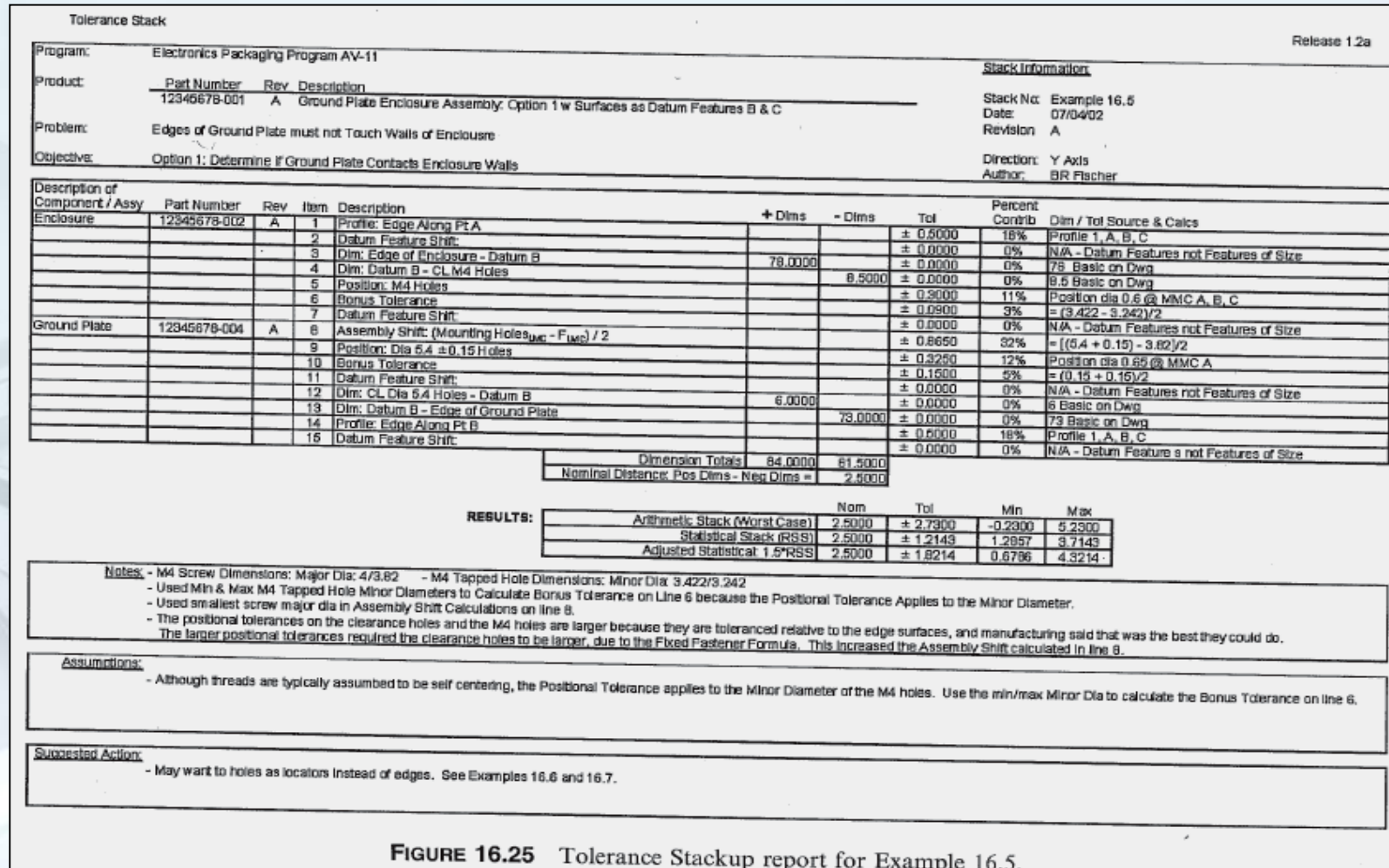
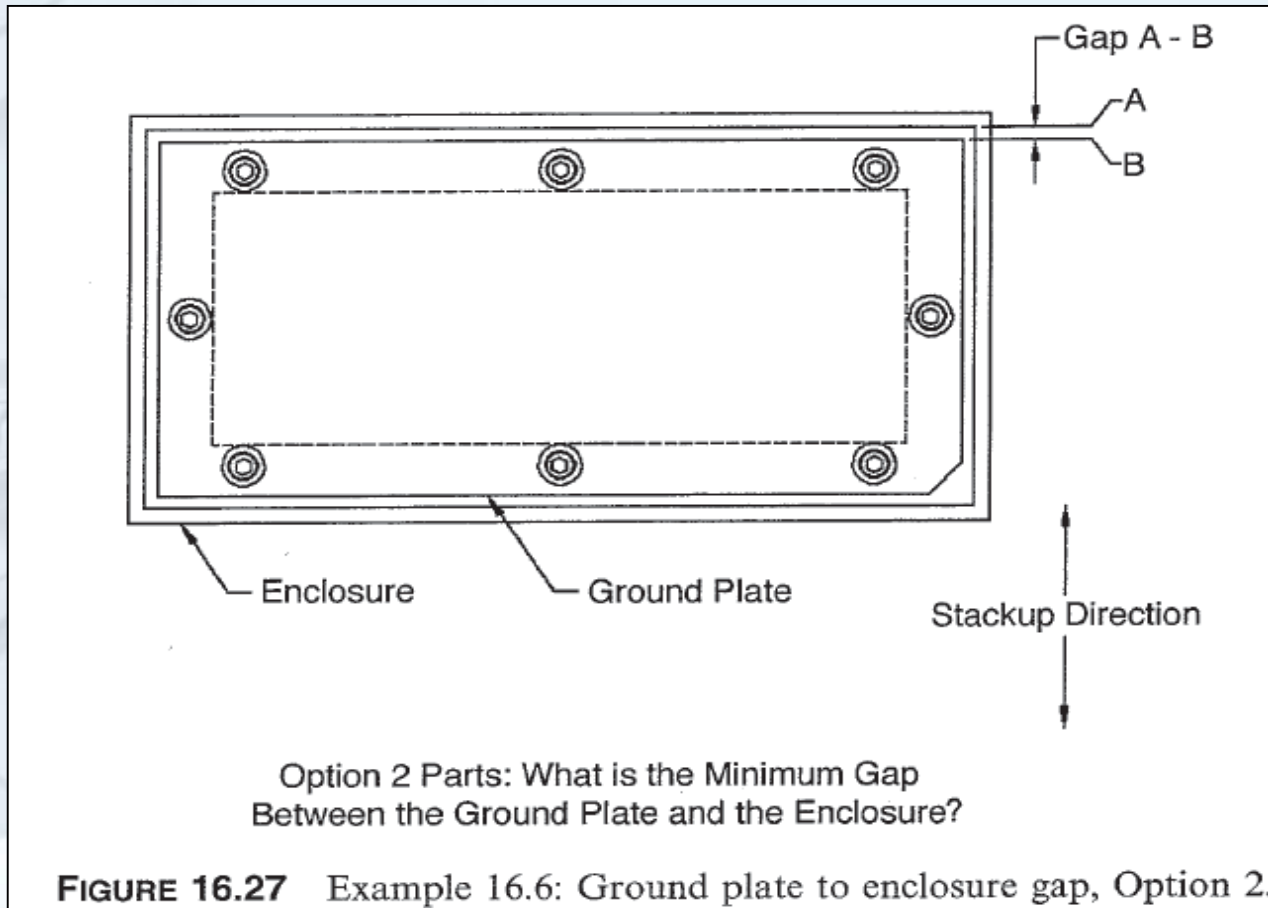

FIGURE 16.25 Tolerance Stackup report for Example 16.5.



**Example 16.6. Ground Plate to Enclosure Gap Study: Option 2**

**Determine if the ground plate contacts the inside walls of the enclosure.**



Extra data:

- M4 tapped hole Dims:  
Minor diameter=3.242-3.422.
- M4 x 8 socket head cap screw  
Dims:  
Major diameter 3.82-4.

## Example 16.6. Ground Plate to Enclosure Gap Study: Option 2

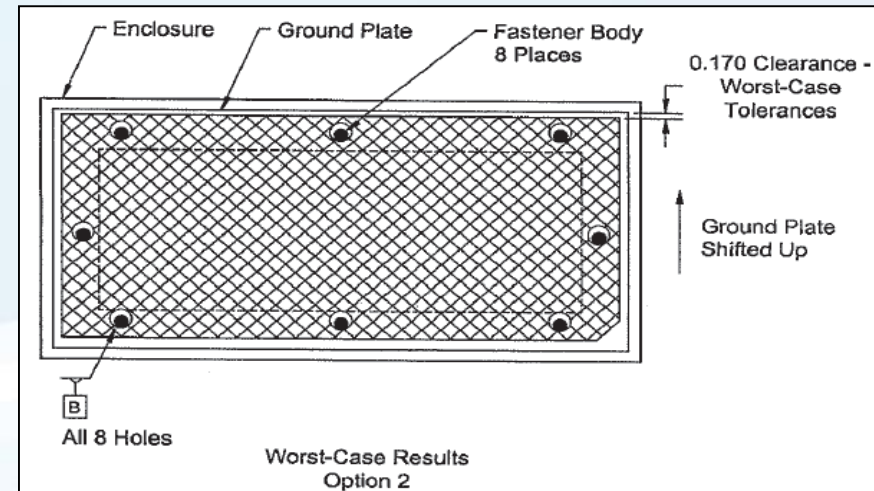
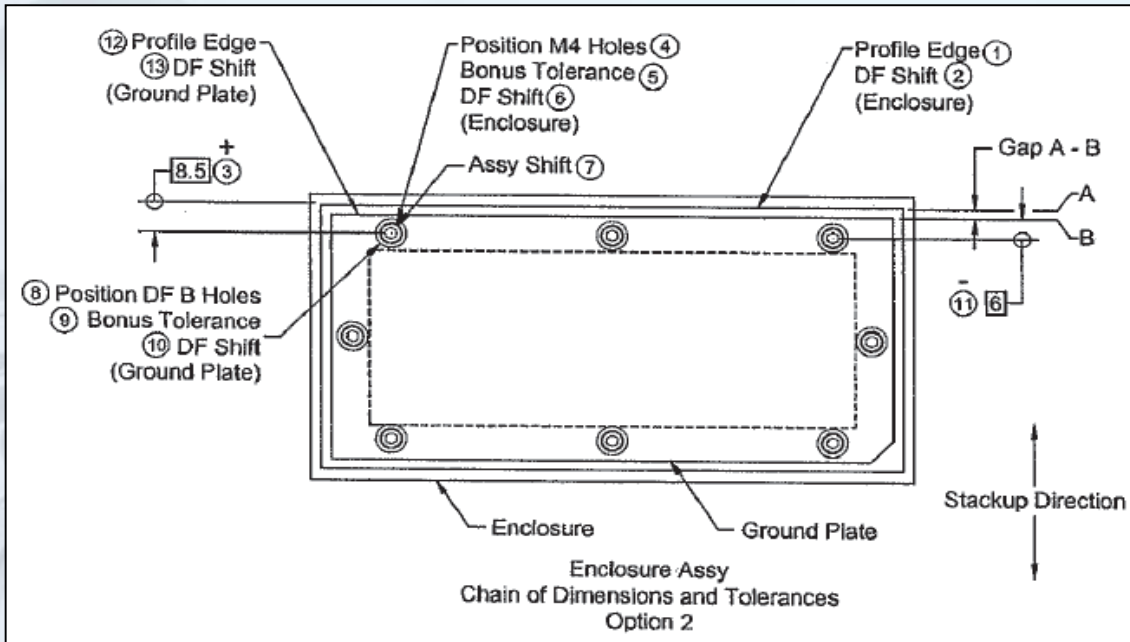



# Chapter #16 Advanced Tolerance Stack-up

## Example 16.6. Ground Plate to Enclosure Gap Study: Option 2

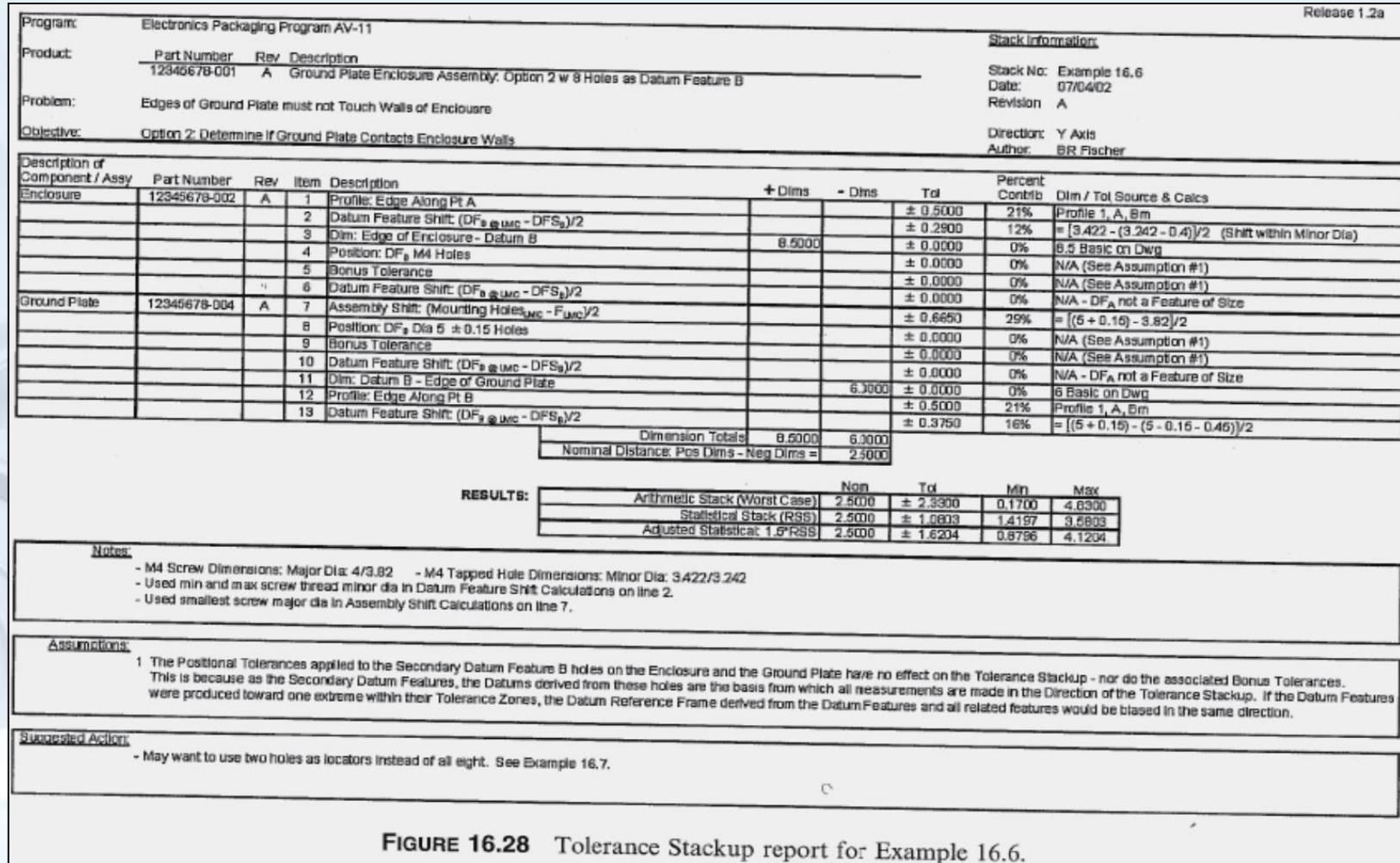
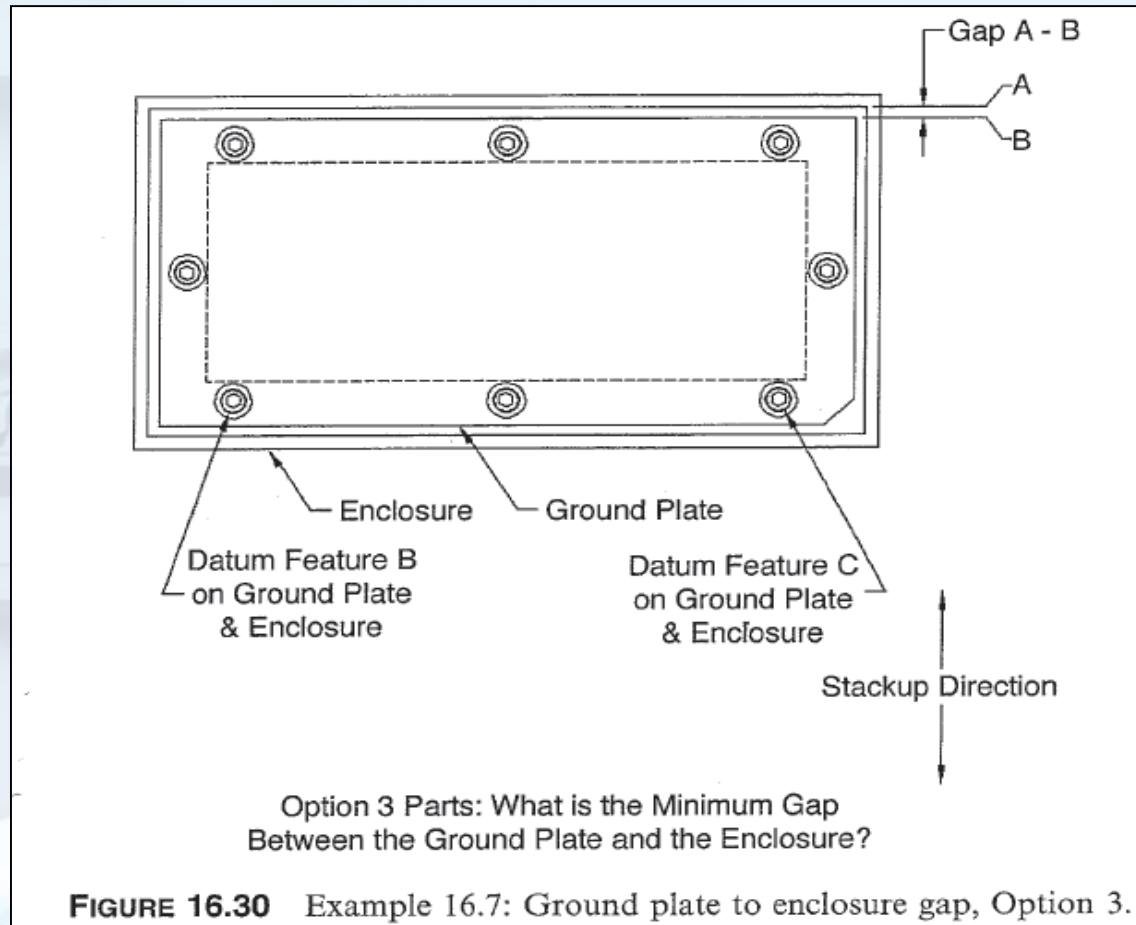

FIGURE 16.28 Tolerance Stackup report for Example 16.6.

### Example 16.7. Ground Plate to Enclosure Gap Study: Option 3

Determine if the ground plate contacts the inside walls of the enclosure.



Extra data:

- M4 tapped hole Dims:  
Minor diameter=3.242-3.422.
- M4 x 8 socket head cap screw  
Dims:  
Major diameter 3.82-4.

## Example 16.7. Ground Plate to Enclosure Gap Study: Option 3

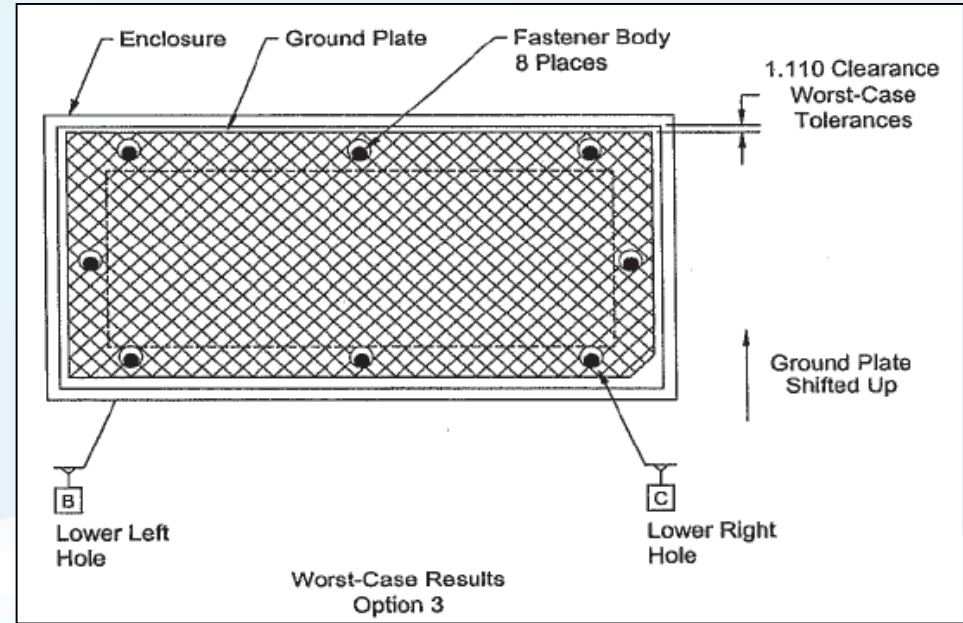
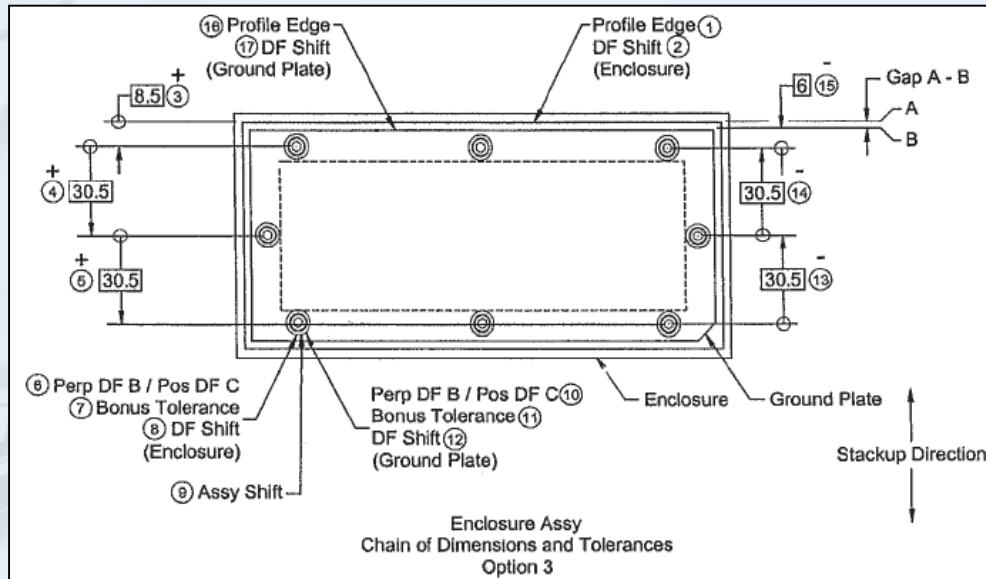



# Chapter #16 Advanced Tolerance Stack-up

## Example 16.7. Ground Plate to Enclosure Gap Study: Option 3

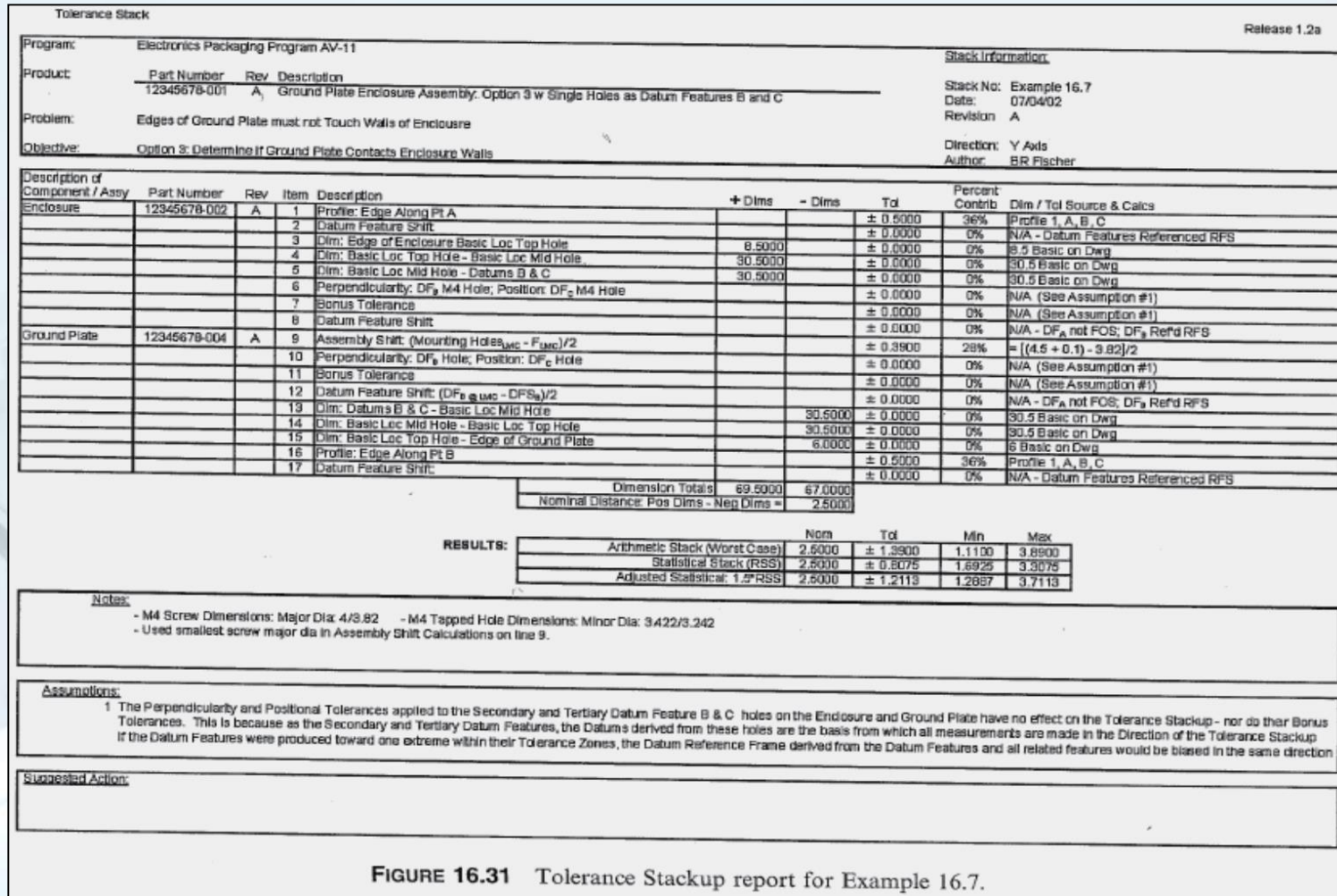

FIGURE 16.31 Tolerance Stackup report for Example 16.7.

# Chapter #17

QUALITY

## Component Tolerance Calculation



### Calculating Component Tolerances Given a Final Assembly Tolerance Requirement

- **Three Methods to calculating component tolerances if given a final assembly tolerance Requirement:**
  1. manually adjusts
  2. “what-if” method:
  3. Goal Seek function: Microsoft Excel :



Component Tolerance Calculation

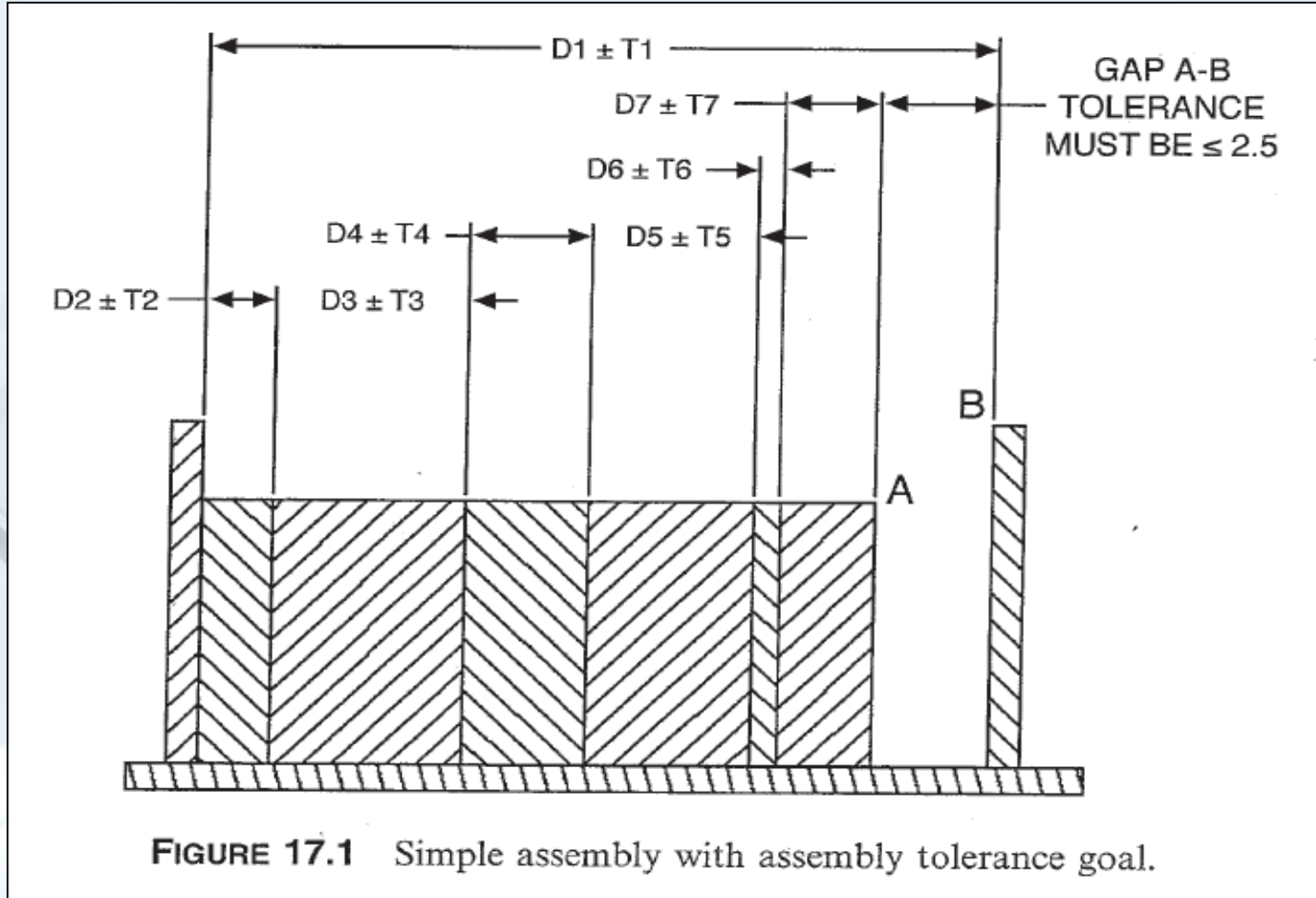

FIGURE 17.1 Simple assembly with assembly tolerance goal.

## Chapter #17 Component Tolerance Calculation

### “what-if” method: Guess

#### Tolerance Stackup

Product: Sample Assembly with Gap Tolerance Only Date: 07/04/02

Problem: Component Dimensions must be Toleranced to Achieve Assy Tolerance Requirement

Objective: Determine the Tolerance for the of Each Dimension

Revision: A
-------------

Direction: X Axis
-------------------

Guess #1 Try +/-0.5 tolerance for each Dimension

Component / Assy	Item	Description	Tol	Tol Source & Calcs
Dimension 1	1	Tolerance T1	+/- 0.5	Guess #1
Dimension 2	2	Tolerance T2	+/- 0.5	"
Dimension 3	3	Tolerance T3	+/- 0.5	"
Dimension 4	4	Tolerance T4	+/- 0.5	"
Dimension 5	5	Tolerance T5	+/- 0.5	"
Dimension 6	6	Tolerance T6	+/- 0.5	"
Dimension 7	7	Tolerance T7	+/- 0.5	"

Arithmetic Stack (Worst Case) +/- 3.500

Statistical Stack (RSS) +/- 1.323

Adjusted Stack: 1.5\*RSS +/- 1.984

← Too small -  
Tolerances  
may be larger

## Chapter #17 Component Tolerance Calculation

### “what-if” method: Guess

Guess #2		Try +/-0.75 tolerance for each Dimension		
Component / Assy	Item	Description	Tol	Tol Source & Calcs
Dimension 1	1	Tolerance T1	+/- 0.75	Guess #2
Dimension 2	2	Tolerance T2	+/- 0.75	"
Dimension 3	3	Tolerance T3	+/- 0.75	"
Dimension 4	4	Tolerance T4	+/- 0.75	"
Dimension 5	5	Tolerance T5	+/- 0.75	"
Dimension 6	6	Tolerance T6	+/- 0.75	"
Dimension 7	7	Tolerance T7	+/- 0.75	"
			Arithmetic Stack (Worst Case)	+/- 5.250
			Statistical Stack (RSS)	+/- 1.984
			Adjusted Stack: 1.5*RSS	+/- 2.976 ← Too large - Tolerances must be smaller

Guess #3		Try +/-0.63 tolerance for each Dimension		
Component / Assy	Item	Description	Tol	Tol Source & Calcs
Dimension 1	1	Tolerance T1	+/- 0.63	Guess #3
Dimension 2	2	Tolerance T2	+/- 0.63	"
Dimension 3	3	Tolerance T3	+/- 0.63	"
Dimension 4	4	Tolerance T4	+/- 0.63	"
Dimension 5	5	Tolerance T5	+/- 0.63	"
Dimension 6	6	Tolerance T6	+/- 0.63	"
Dimension 7	7	Tolerance T7	+/- 0.63	"
			Arithmetic Stack (Worst Case)	+/- 4.410
			Statistical Stack (RSS)	+/- 1.667
			Adjusted Stack: 1.5*RSS	+/- 2.500 ← Satisfies Overall Requirement
<div style="border: 1px solid black; display: inline-block; padding: 5px;">Use +/-0.63mm tolerance for each Dimension</div>				

“what-if” method: Guess - RSS

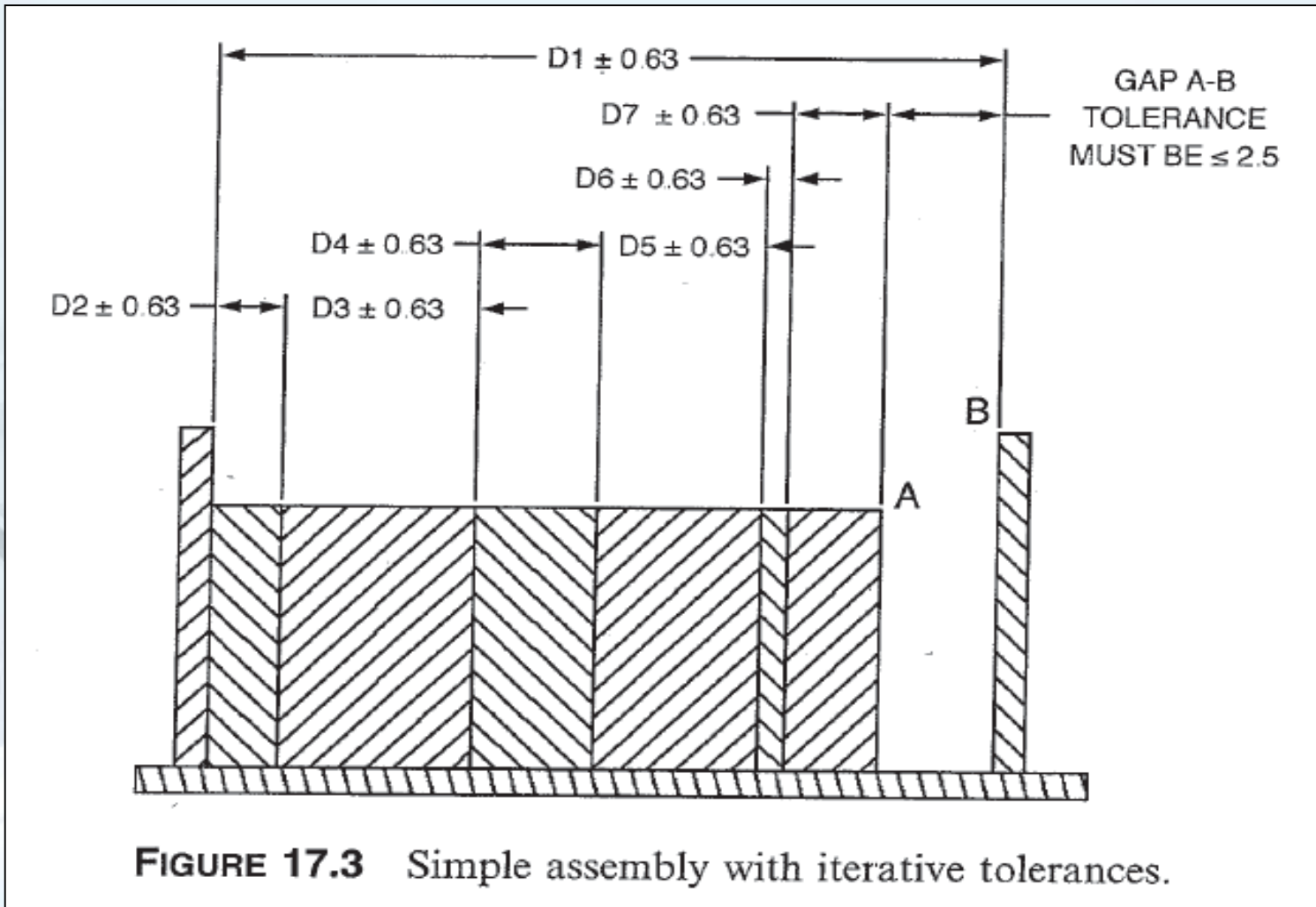

### “what-if” method: Guess - RSS

Formula:

$$PT = \frac{TOL}{ADJ \sqrt{n}}$$

Where:

n = Number of Parts in Assembly

TOL = Overall or Gap Tolerance (Given)

PT = Part Tolerance (Calculated)

ADJ = RSS Adjustment Factor

Note:

Use ADJ = 1 for straight RSS Stackup  
(no adjustment factor)

Sample Problem:

Example in Figure 17.1 Solved:

$$PT = \frac{TOL}{ADJ \sqrt{n}}$$

$$PT = \frac{2.5}{1.5 \sqrt{7}}$$

$$PT = 0.63$$

**FIGURE 17.4** Adjusted RSS part allocation formula.



# Chapter #18

QUALITY

## Floating/Fixed Fastener Calculation





### Floating And Fixed Fastener

- Floating fastener and fixed fastener are terms describing two possible relationships between the corresponding features in mating parts.

These features include clearance holes, tight-fitting holes, tapped holes, slots, pins, studs, keys, keyways, etc.

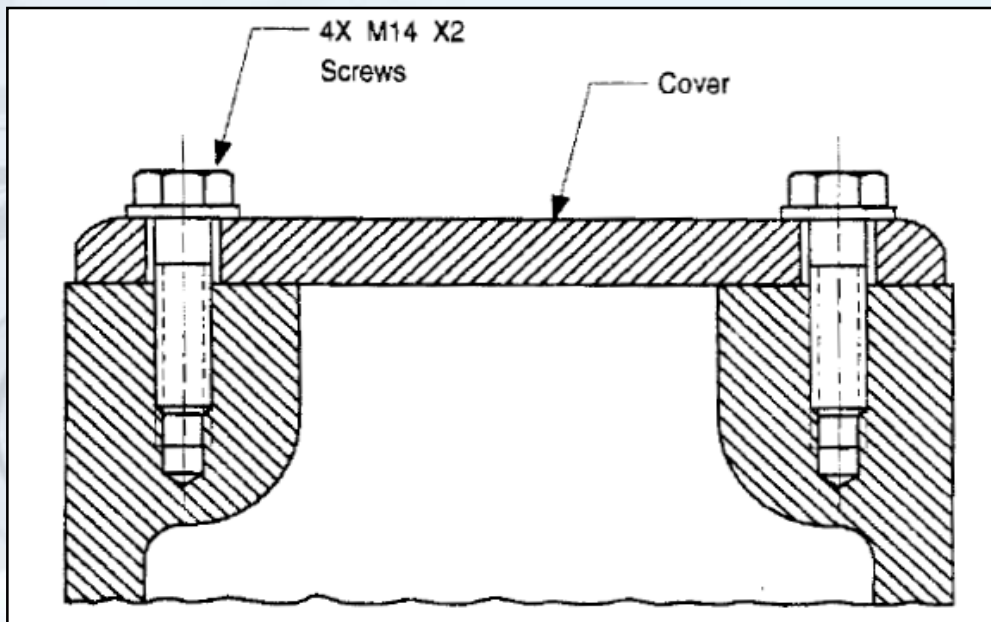

**FIXED FASTENER**

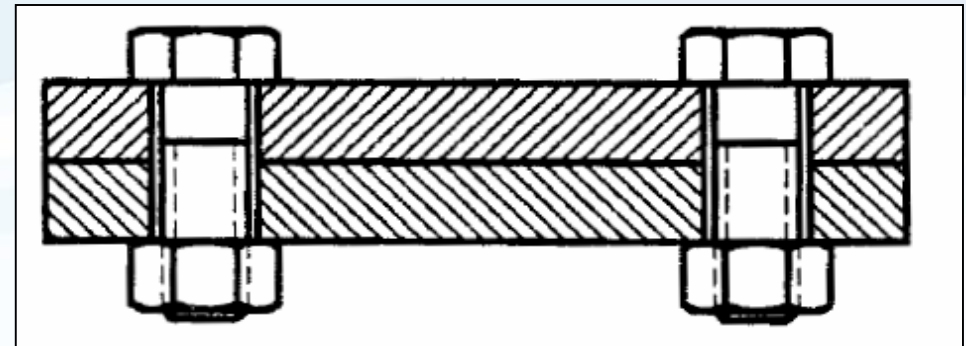

**FLOATING FASTENER**

## Floating-fastener Situation

**Definition:** Where internal features, such as holes, in one or more parts must clear a common external feature, such as a fastener or a shaft, is referred to as a floating-fastener situation.

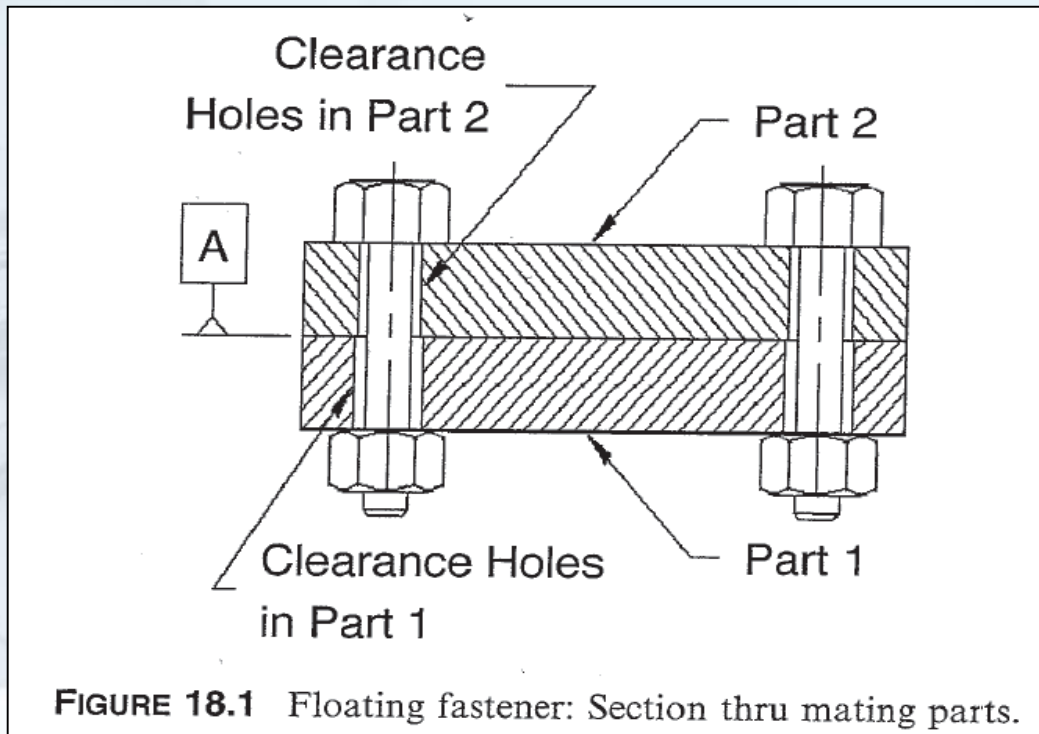

*Floating-fastener formula:*

$$H = F + T$$

$H$  = minimum clearance hole diameter (MMC)  
 $F$  = maximum fastener diameter (MMC)  
 $T$  = clearance hole positional tolerance at MMC  
in considered part







### Floating-fastener Situation

The tolerance zones on a part would have additional orientation error if a different feature or surface was chosen as the primary datum feature for the positional tolerance applied to the holes. This applies to the floating-fastener and the fixed-fastener formulas.

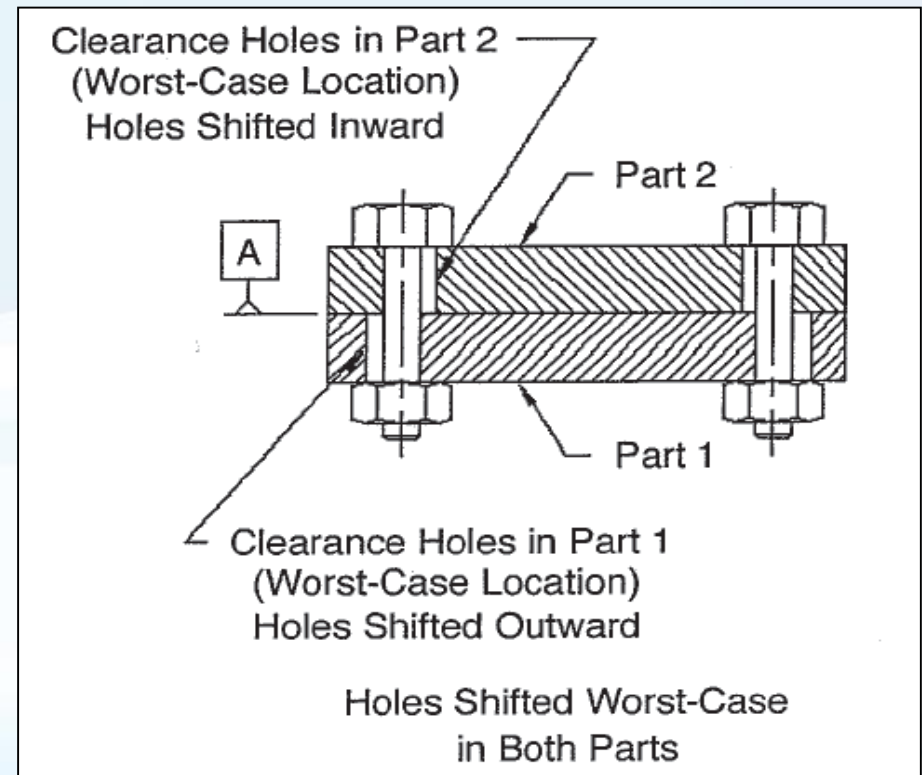
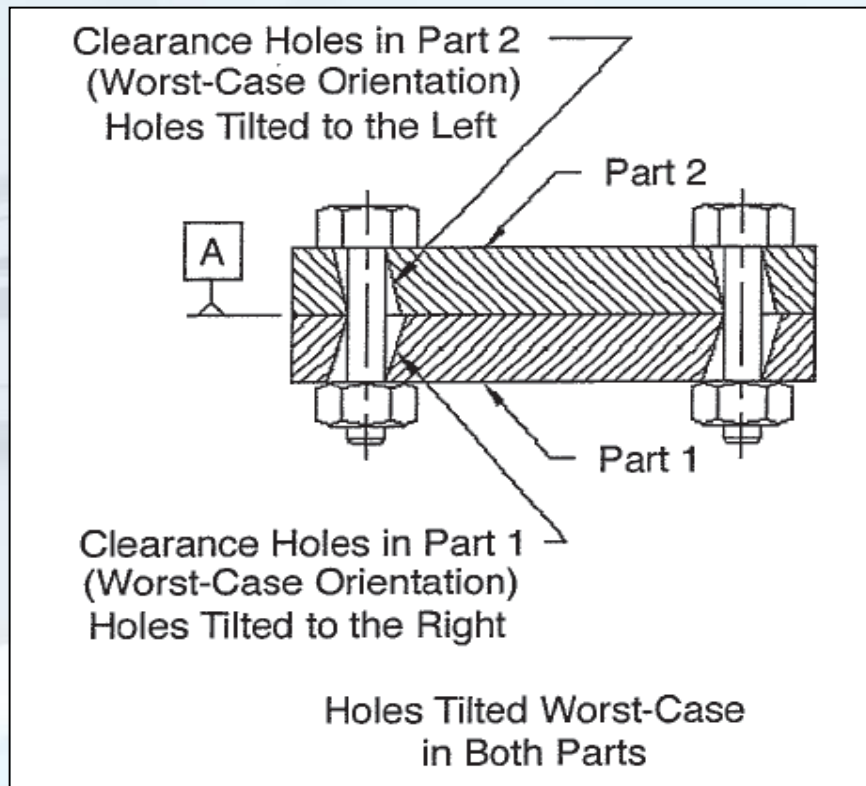

### Floating-fastener Situation

Using the floating-fastener formula ensures that the virtual condition of the holes allows the fastener to pass. In most applications, parts may shift relative to one another about the fasteners at assembly, which is assembly shift.

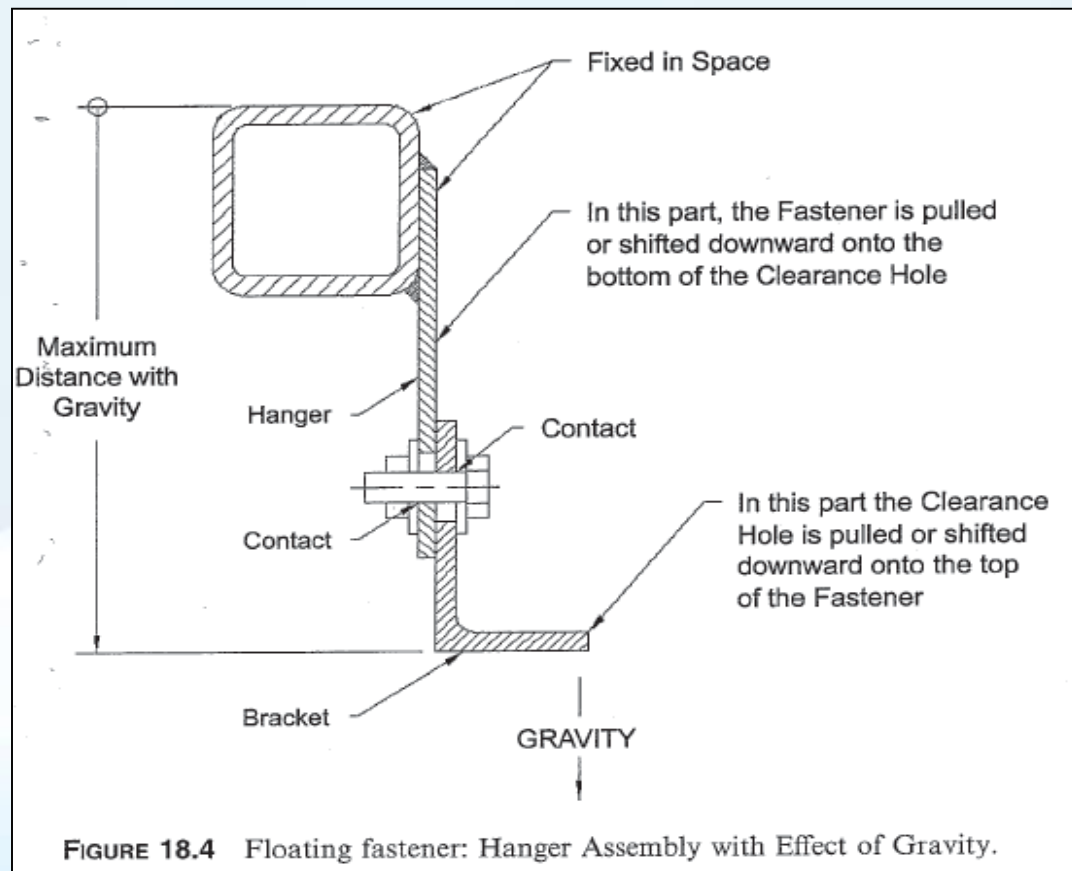



## Floating-fastener Situation

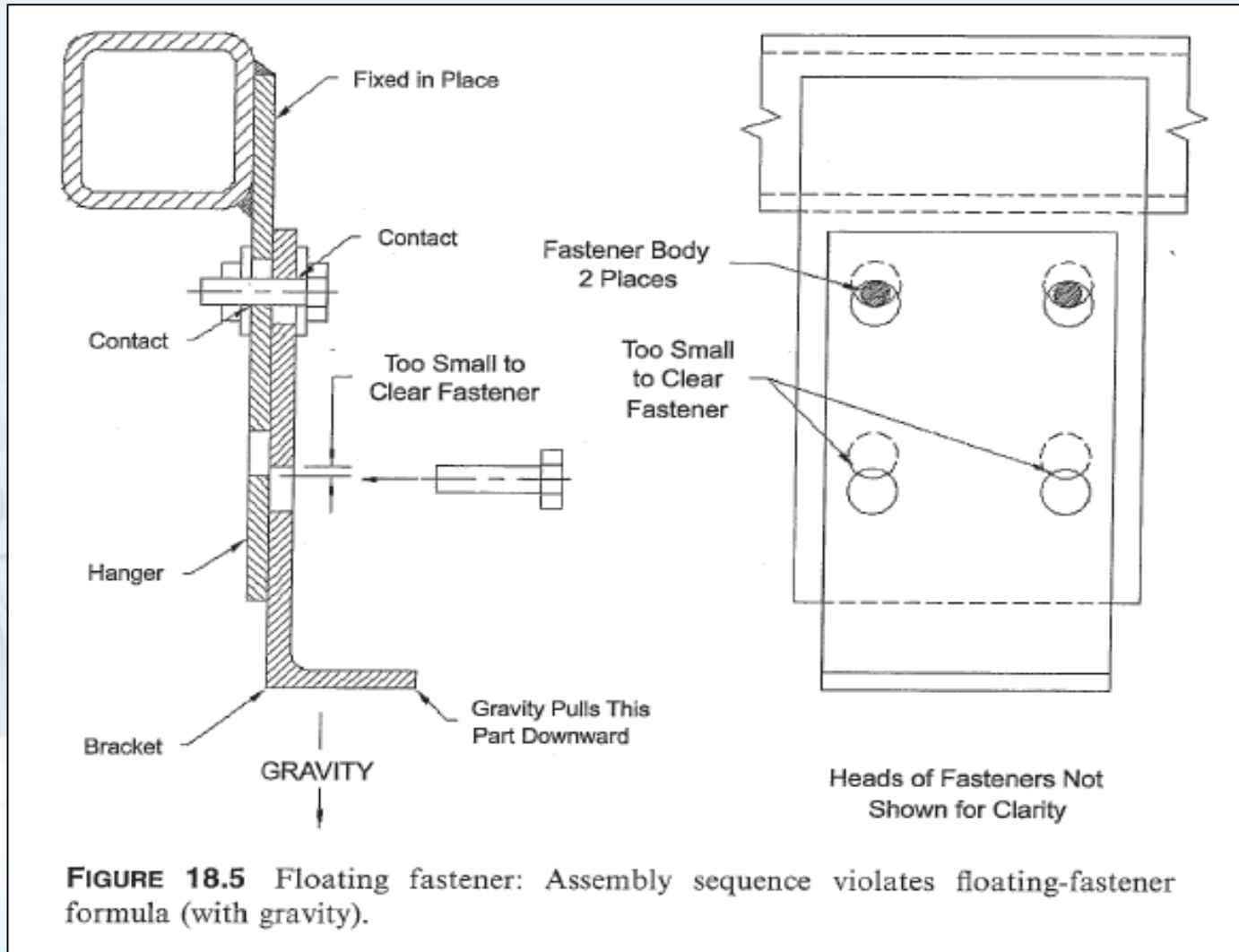

### Floating-fastener Situation

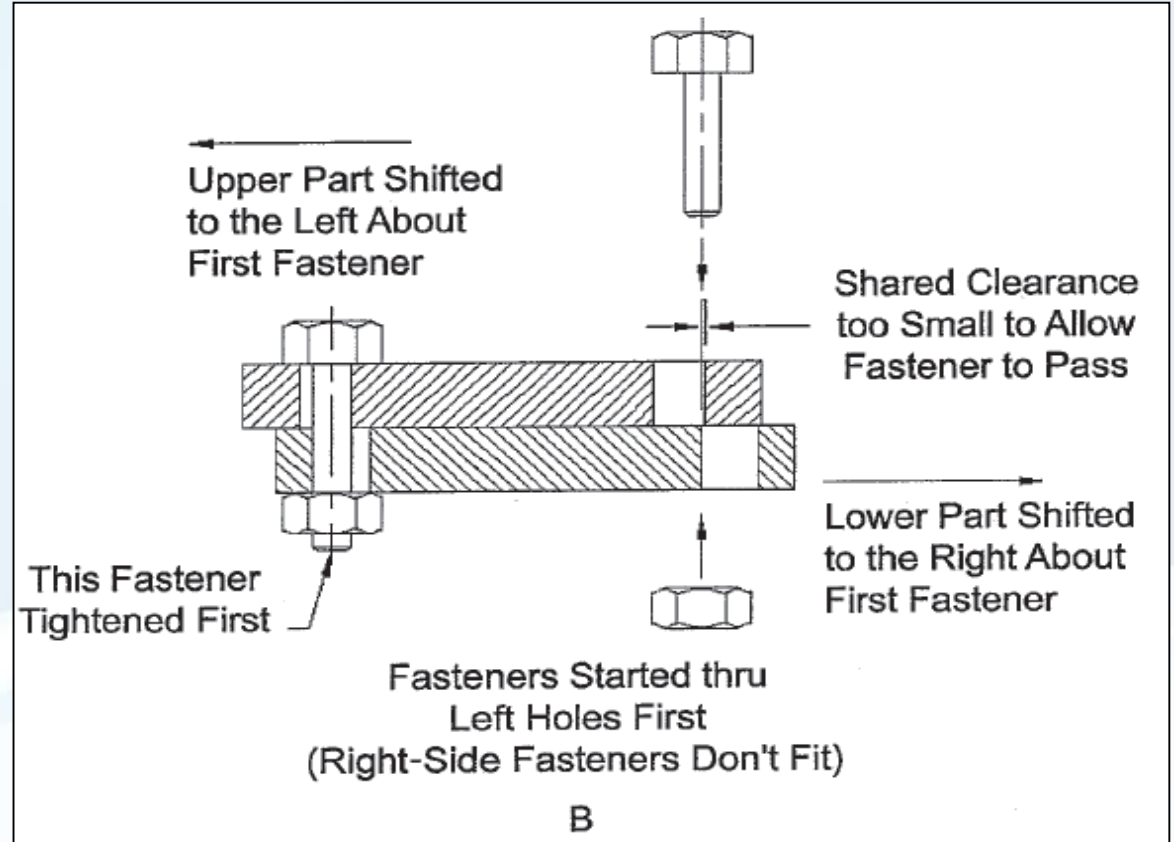
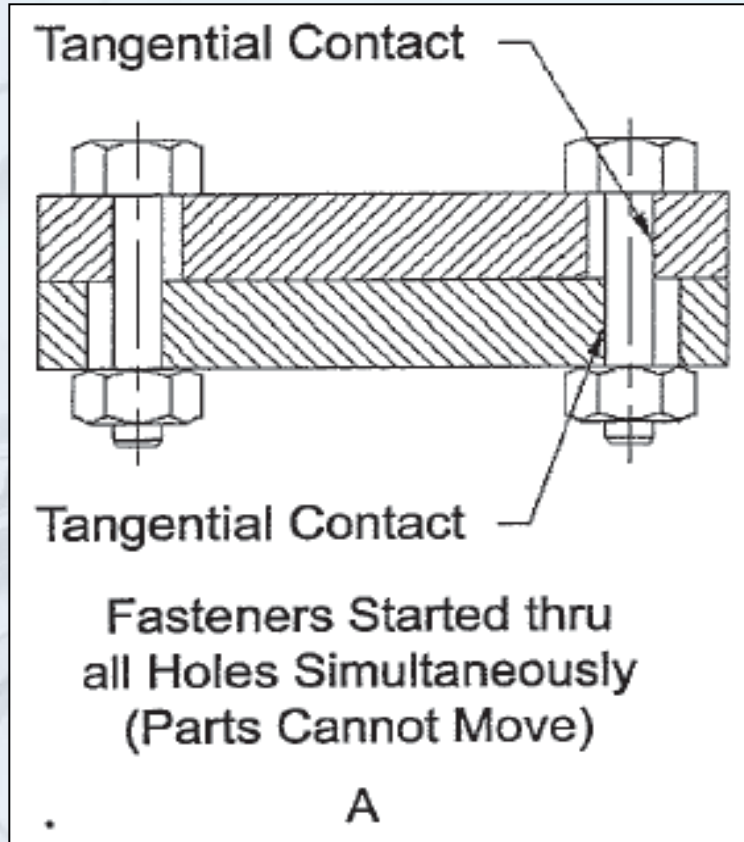

**FIGURE 18.6** Floating fastener: Assembly sequence violates floating-fastener formula (horizontal).

### Fixed-fastener Situation

**Definition:** Where external features, such as pins or studs, are fixed in place. in one part and pass through internal features, such as clearance holes, in a mating part is referred to as a fixed-fastener situation.

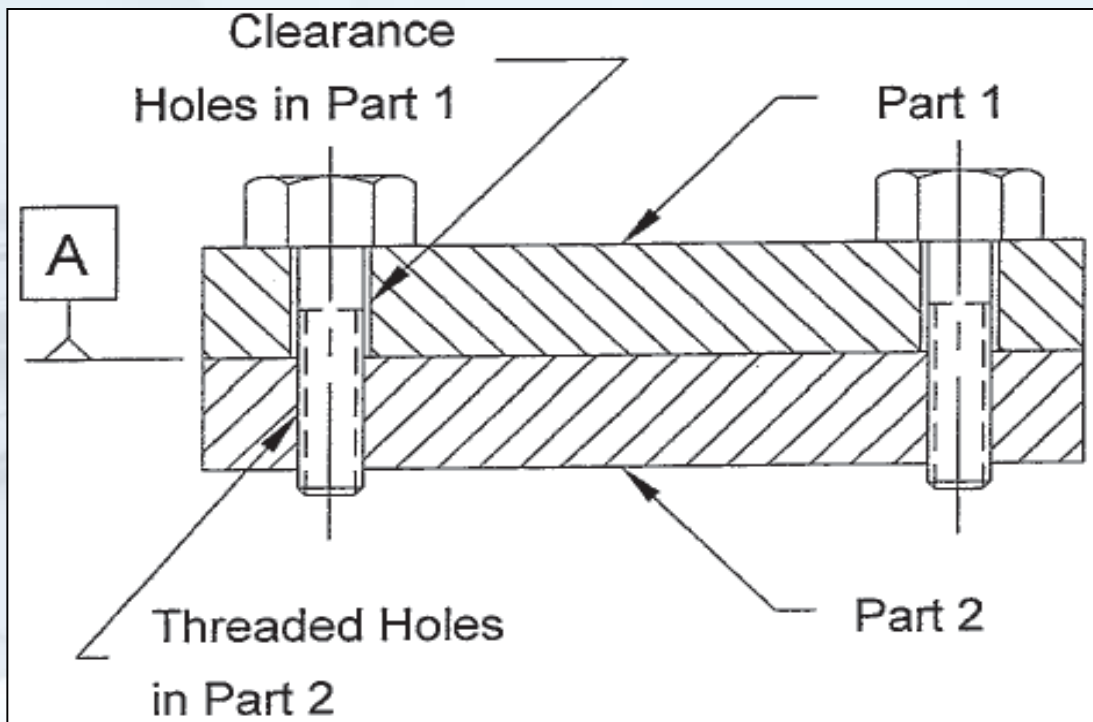

*Fixed-fastener formula:*

$$H = F + T_1 + T_2$$

- $H$  = minimum clearance hole diameter (MMC)
- $F$  = Maximum fastener diameter (MMC)
- $T_1$  = clearance hole positional tolerance at MMC
- $T_2$  = threaded hole positional tolerance at MMC

Fixed-fastener Situation

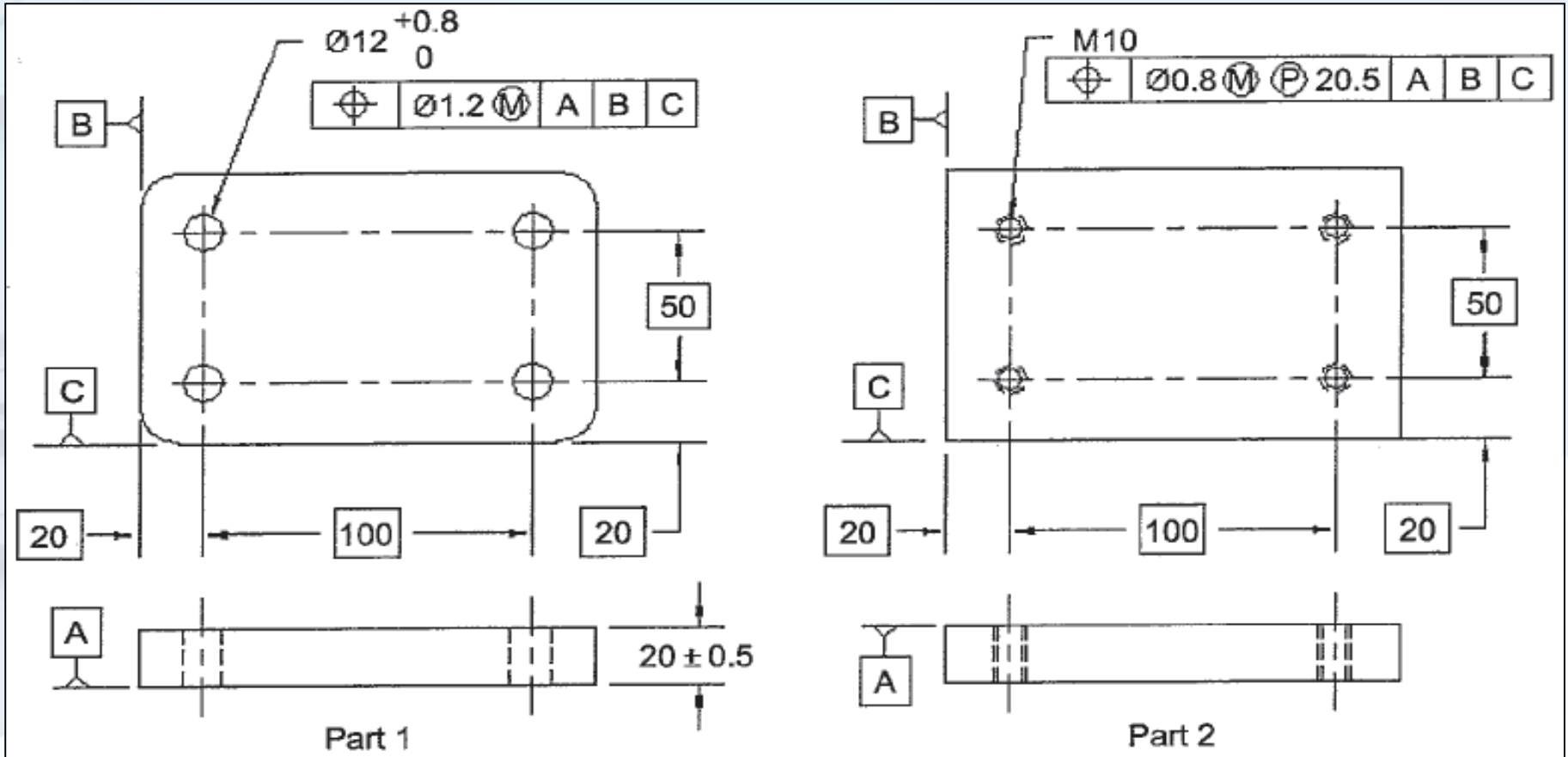

### Fixed-fastener Situation

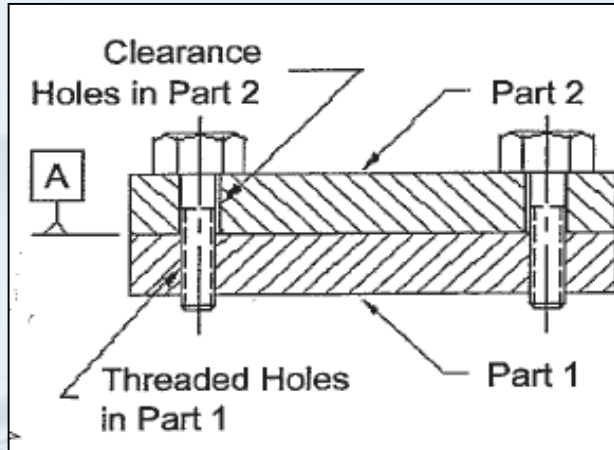

These parts have a Fixed-Fastener relationship. One of the parts has threaded holes, and the other has clearance holes. Threaded fasteners tend to center in the threaded holes (the fasteners are located where the threaded holes are located). The Positional Tolerance for both parts depends on the amount the clearance holes are oversized, and must be shared between the parts. The Positional Tolerance on both hole patterns are not independent. Note: The Fixed-Fastener Formula requires using a projected tolerance zone for the threaded holes.

Fixed-Fastener Formula (See ASME Y 14.5M-1994 Appendix B)

$$H = F + T_1 + T_2$$

Where  $H$  = Minimum Clearance Hole Diameter (MMC)  
 $F$  = Maximum Fastener Diameter (MMC)  
 $T_1$  = Positional Tolerance for Clearance Holes  
 $T_2$  = Positional Tolerance for Tapped Holes

Example:

Given:  $H = 12$ ;  $F = 10$

$$H = F + T_1 + T_2 \rightarrow H - F = T_1 + T_2 \rightarrow 12 - 10 = T_1 + T_2 \rightarrow 2 = T_1 + T_2$$

The 2 mm available may be distributed evenly or unevenly between the two parts. In this example, a smaller amount of the available tolerance was assigned to the threaded holes.

$T_1 = 1.2$  Positional Tolerance Assigned to Part 1,  $T_2 = 0.8$  Positional Tolerance Assigned to Part 2



Fixed-fastener Situation

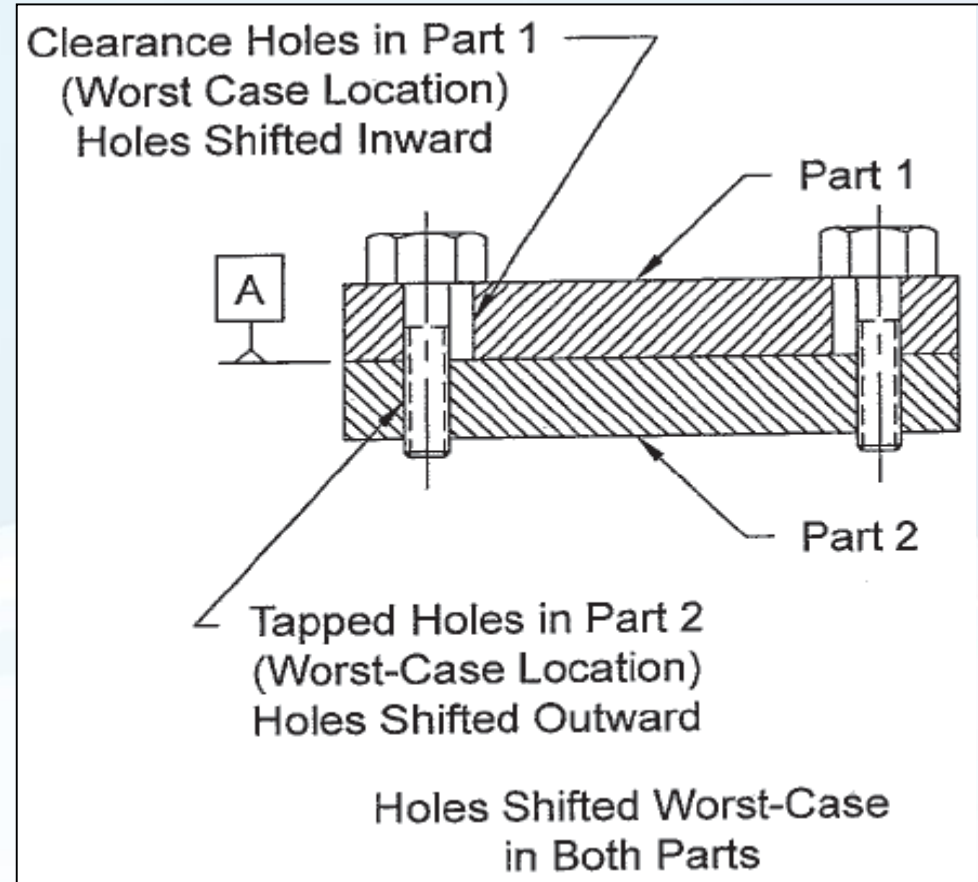
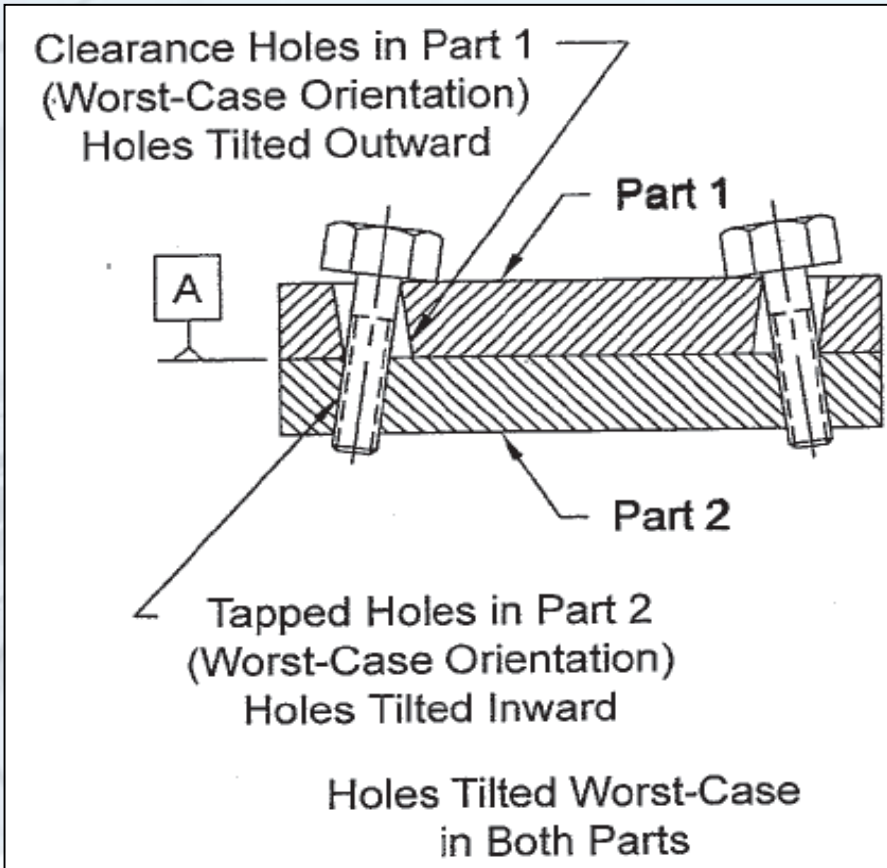



# Chapter #19

QUALITY

## Fit Classification



### Fit Classifications

**Three types of fit between cylindrical parts:**

- 1. clearance fits**
- 2. transition fits**
- 3. interference fits**

**fit classifications do not take into account positional error between parts; the part features are assumed to be coaxial. Typically these fits are used for shafts into bearings, pressing pins into holes, or similar applications.**

### Fit Classifications

#### Clearance fits

**A clearance fit must always have clearance between the shaft and the hole.**

#### Transition fits

**A transition fit may have clearance or interference between the shaft and the hole.**

#### Interference fits (force fits)

**An interference fit must always have interference between the shaft and the hole.**

# Chapter #20

QUALITY

## Form Tolerance Stack-up



### Form Tolerance Stack up

- **The reason that form tolerances are of less concern in linear Tolerance Stack ups is because most Tolerance Stack ups are done to find a minimum or maximum distance, and in the majority of cases the form or shape of a feature has little to no effect on the distance being studied.**

**However, form tolerances may play a role in Tolerance Stack ups. in some cases variation in the form of a feature can have a dramatic effect on the Tolerance Stack up.**

# Form Tolerance Stack up

- **Datum feature form tolerances**

Planar primary datum features are usually toleranced using flatness.

Primary datum features of size may also have form tolerances applied, such as cylindricity or straightness, but such form tolerances will probably not affect the result of a Tolerance Stack up.



### Form Tolerance Stack up

- **Form and orientation tolerances applied to secondary and tertiary datum features may also be considered in Tolerance Stack ups where applicable.**

#### **Form tolerances can affect the result of a Tolerance Stack up in two ways:**

As translational variation only, such as where parts are very rigid or where they are not subjected to forces that may deform the interfacial surfaces at assembly

As rotational variation projected out to a linear displacement, such as where thin-walled or sheet metal parts are subjected to loads that may deform the interfacial surfaces at assembly and the rotational displacement causes other features on the parts to deform

## Form Tolerances Treated As Adding Translational Variation Only

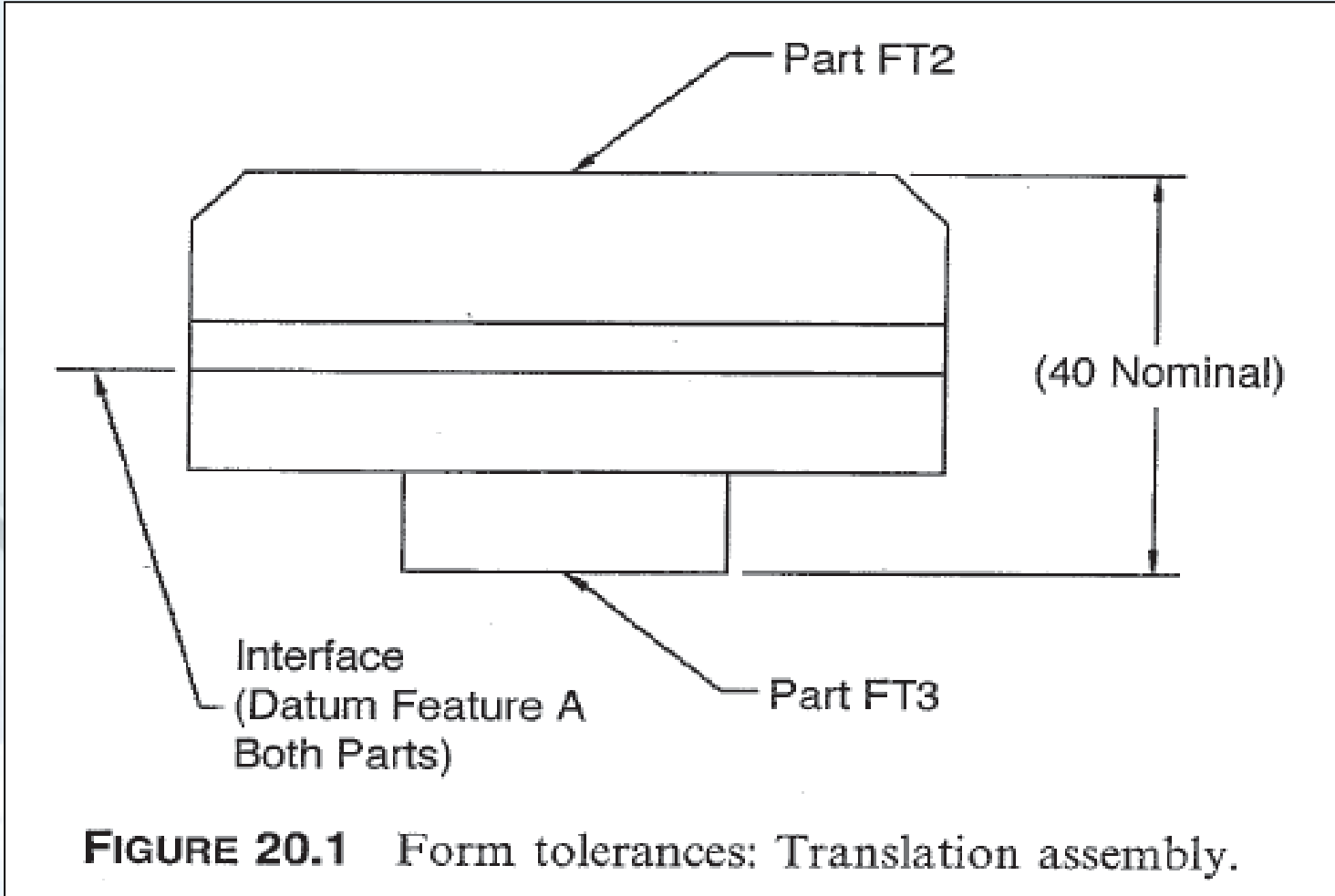

## Chapter #20 Form Tolerance Stack-up

### Form Tolerances Treated As Adding Translational Variation Only

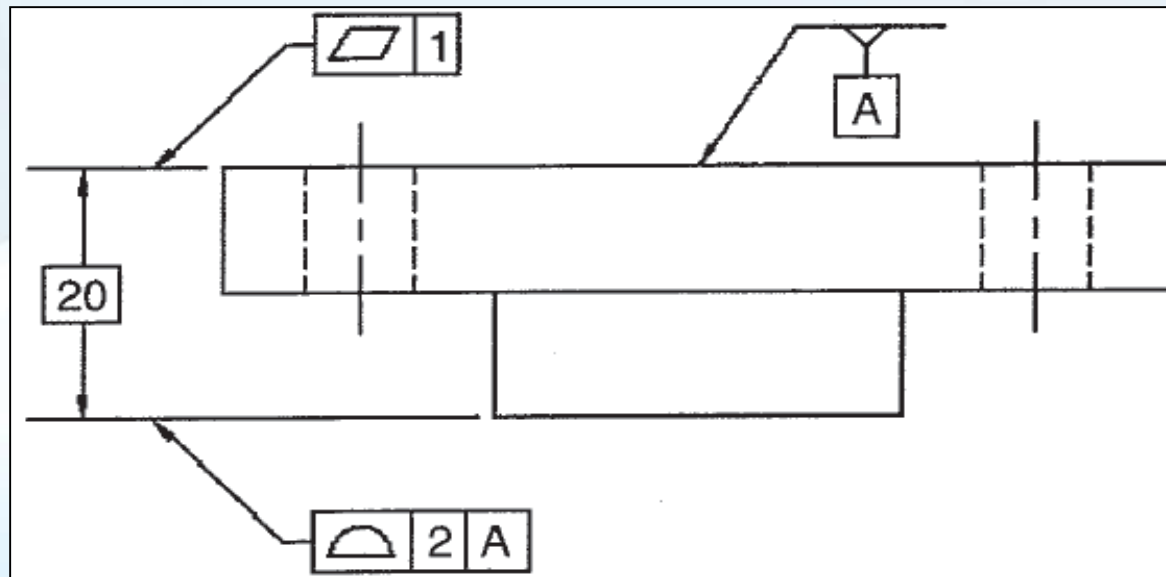
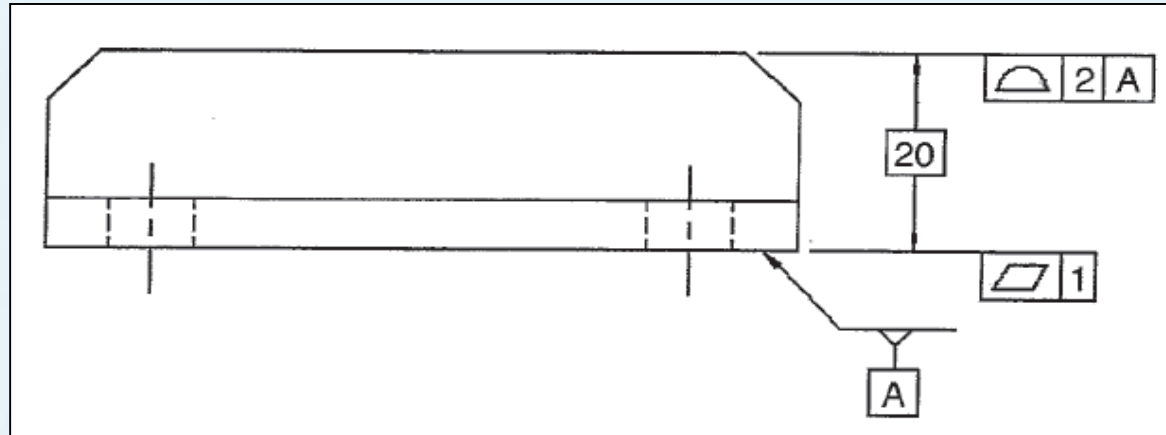

## Form Tolerances Treated As Adding Translational Variation Only

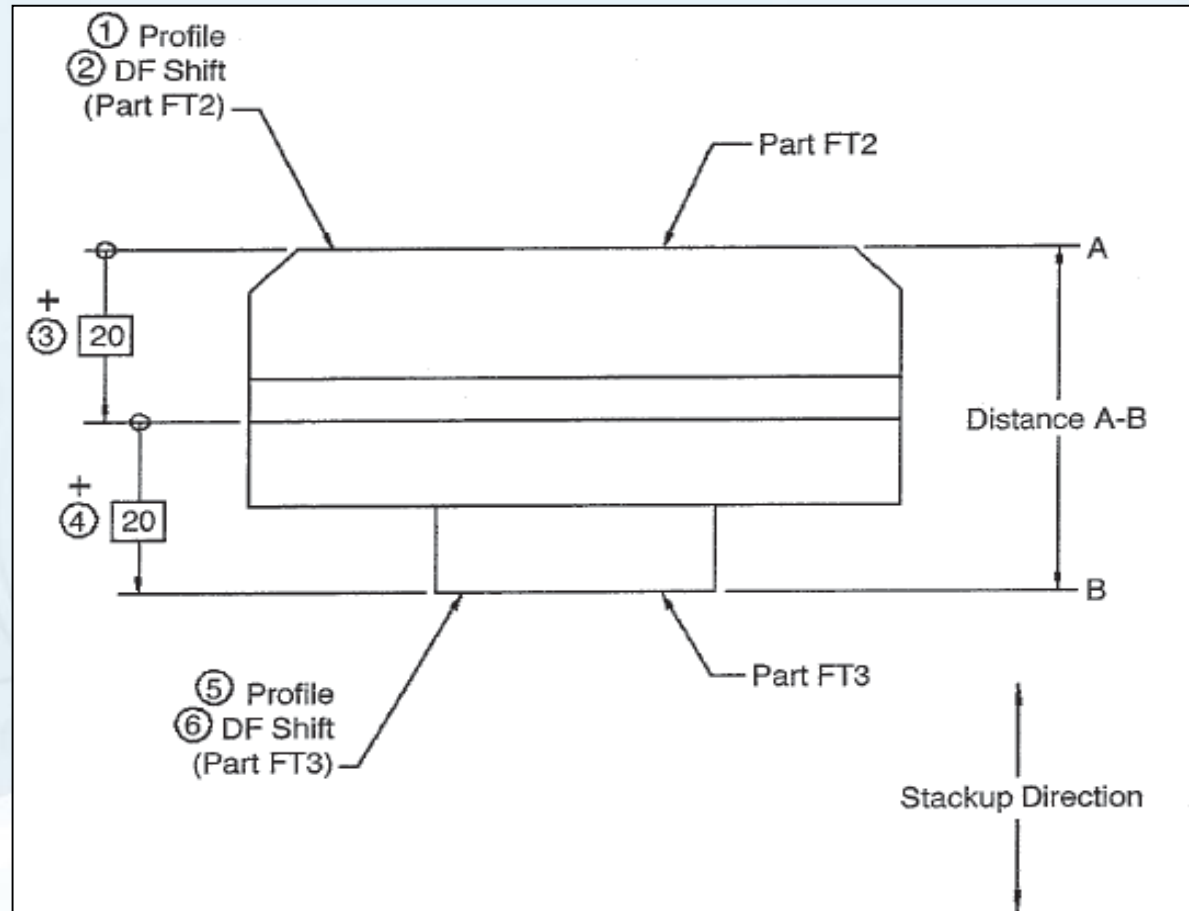

**FIGURE 20.4** Form tolerances: Tolerance Stackup sketch for FT1.

Form Tolerances Treated As Adding Translational Variation Only

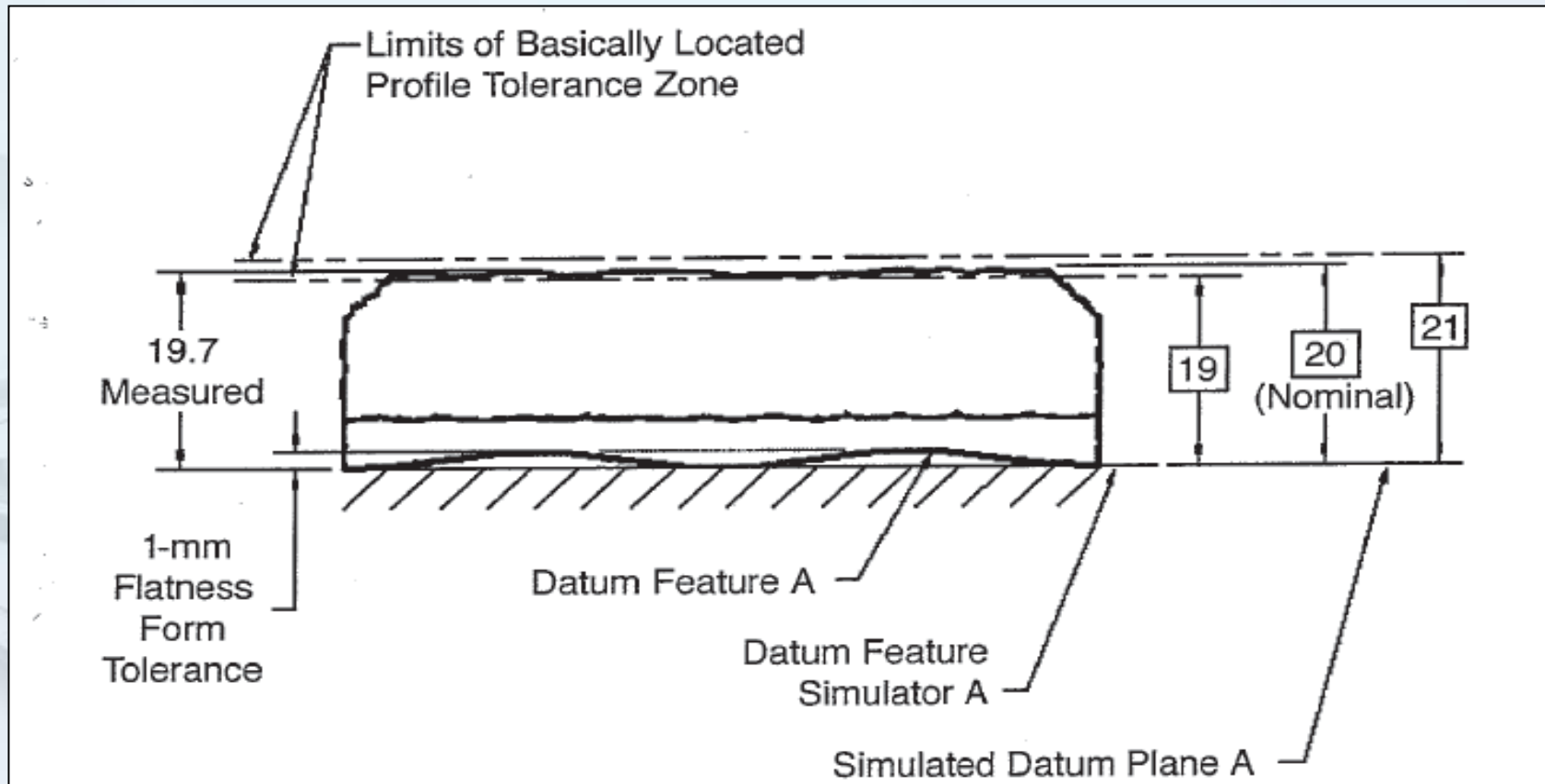

**FIGURE 20.6** Form tolerances: Upper part with variation. As-produced part FT2 at inspection.

Form Tolerances Treated As Adding Translational Variation Only

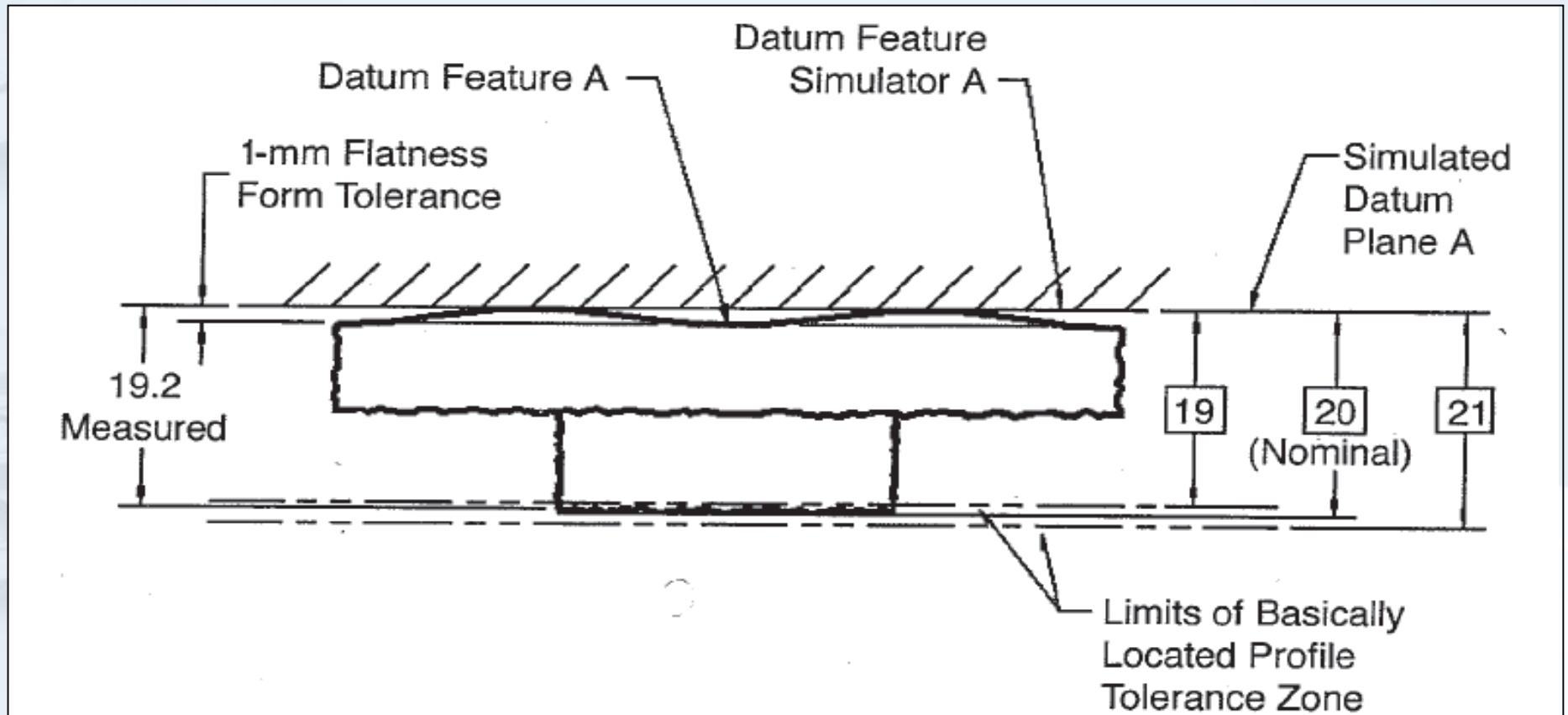
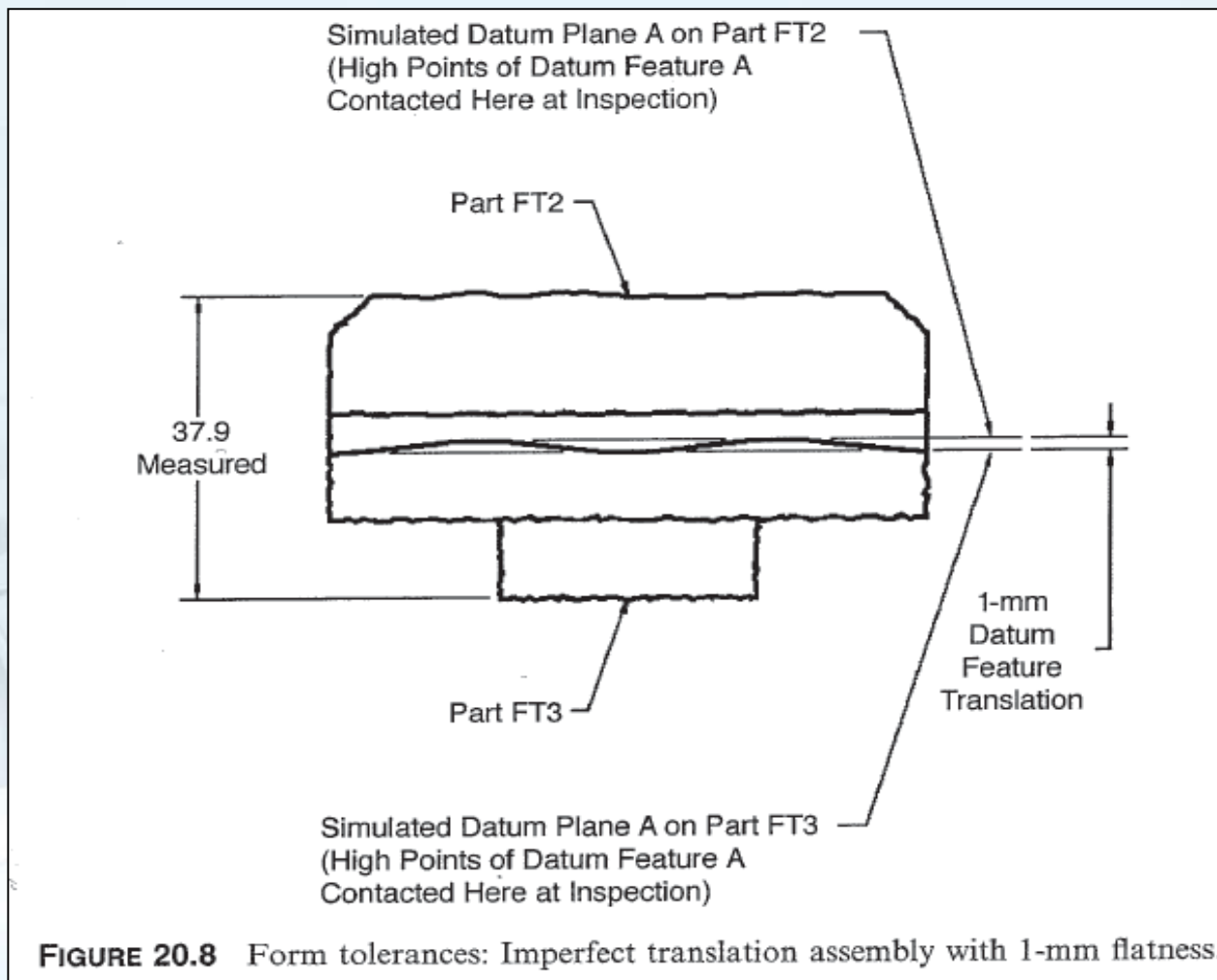

FIGURE 20.7 Form tolerances: lower part with variation. As-produced part FT3 at inspection.



## Form Tolerances Treated As Adding Translational Variation Only



**What's possibility for this happening?**

Form Tolerances Treated As Adding Rotational Variation

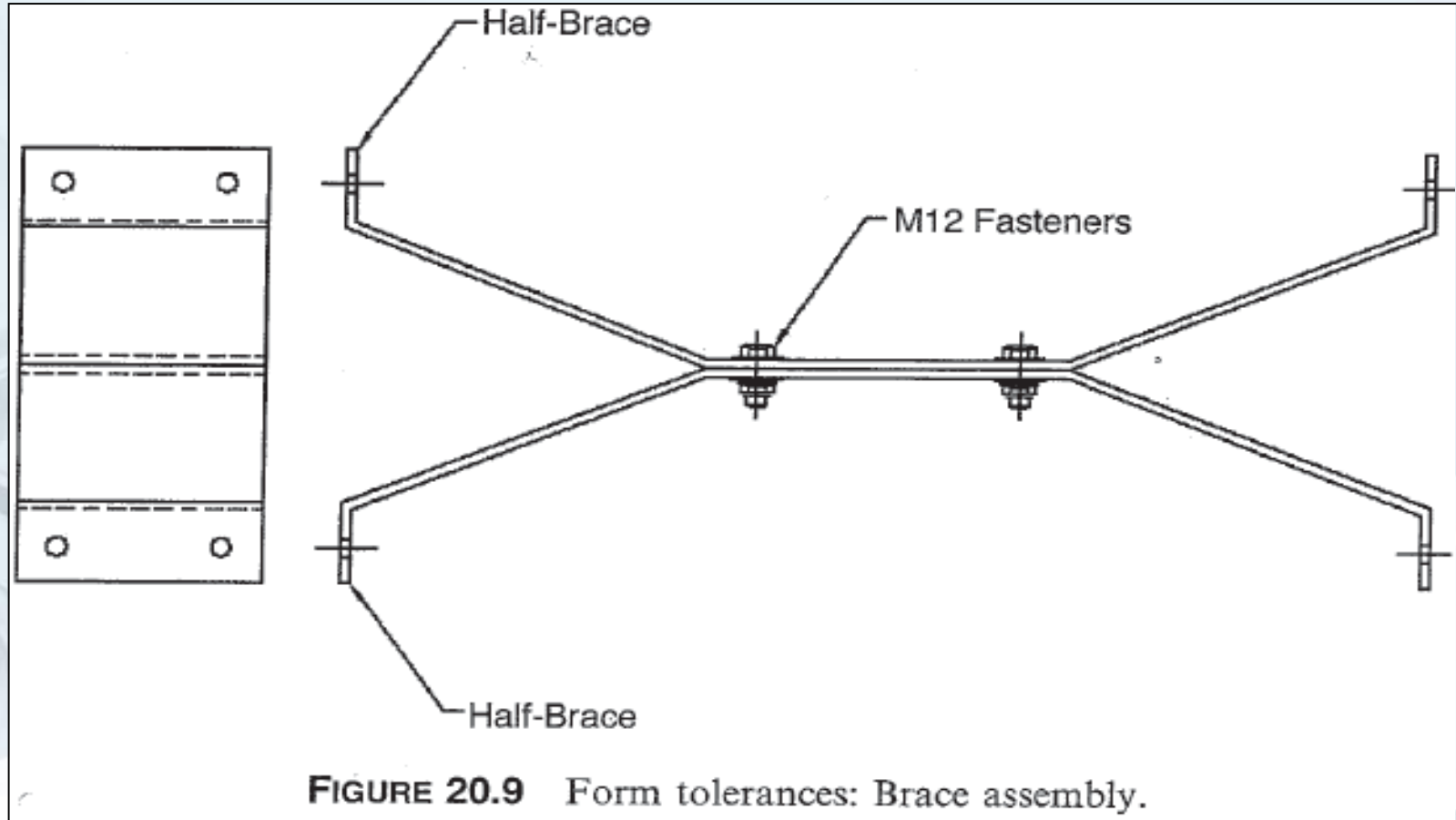

FIGURE 20.9 Form tolerances: Brace assembly.

What's possibility for this happening?

Form Tolerances Treated As Adding Rotational Variation

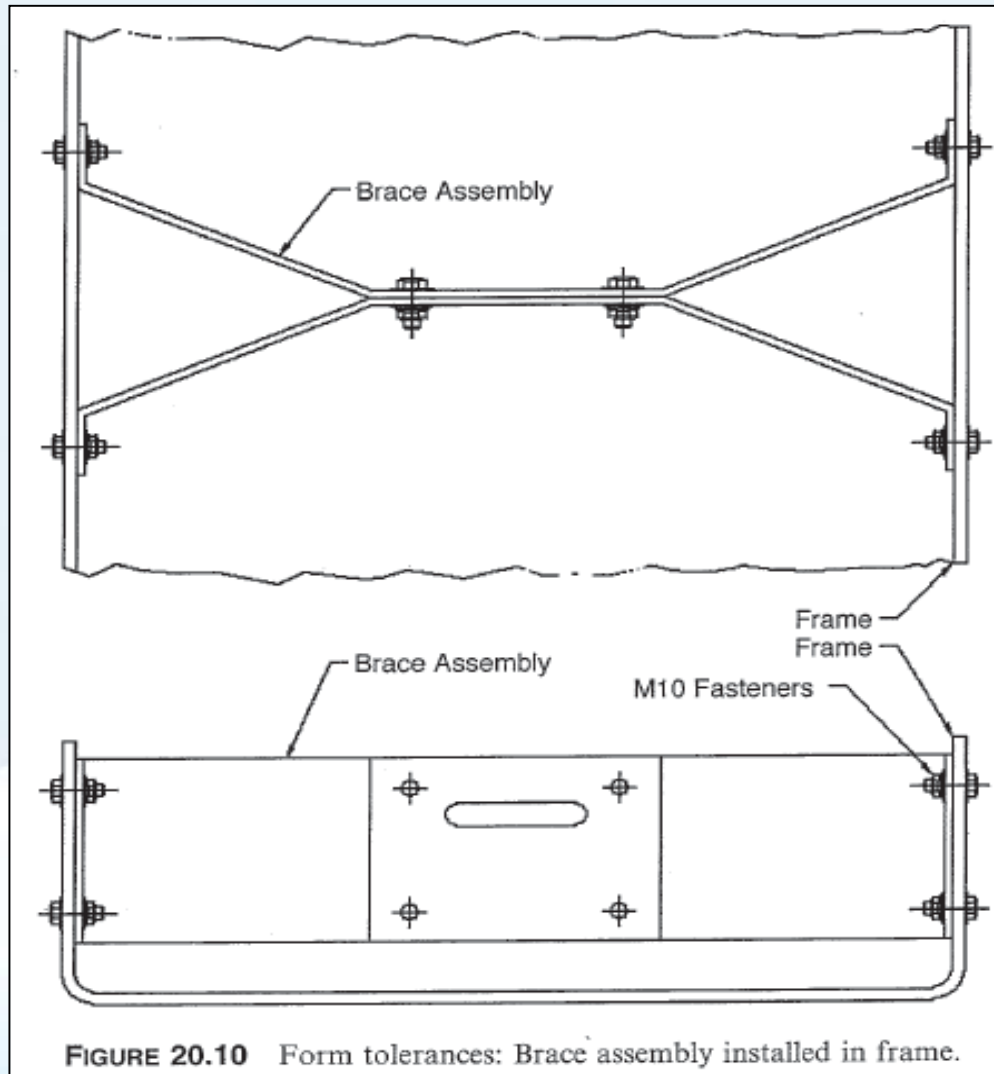

FIGURE 20.10 Form tolerances: Brace assembly installed in frame.

Form Tolerances Treated As Adding Rotational Variation

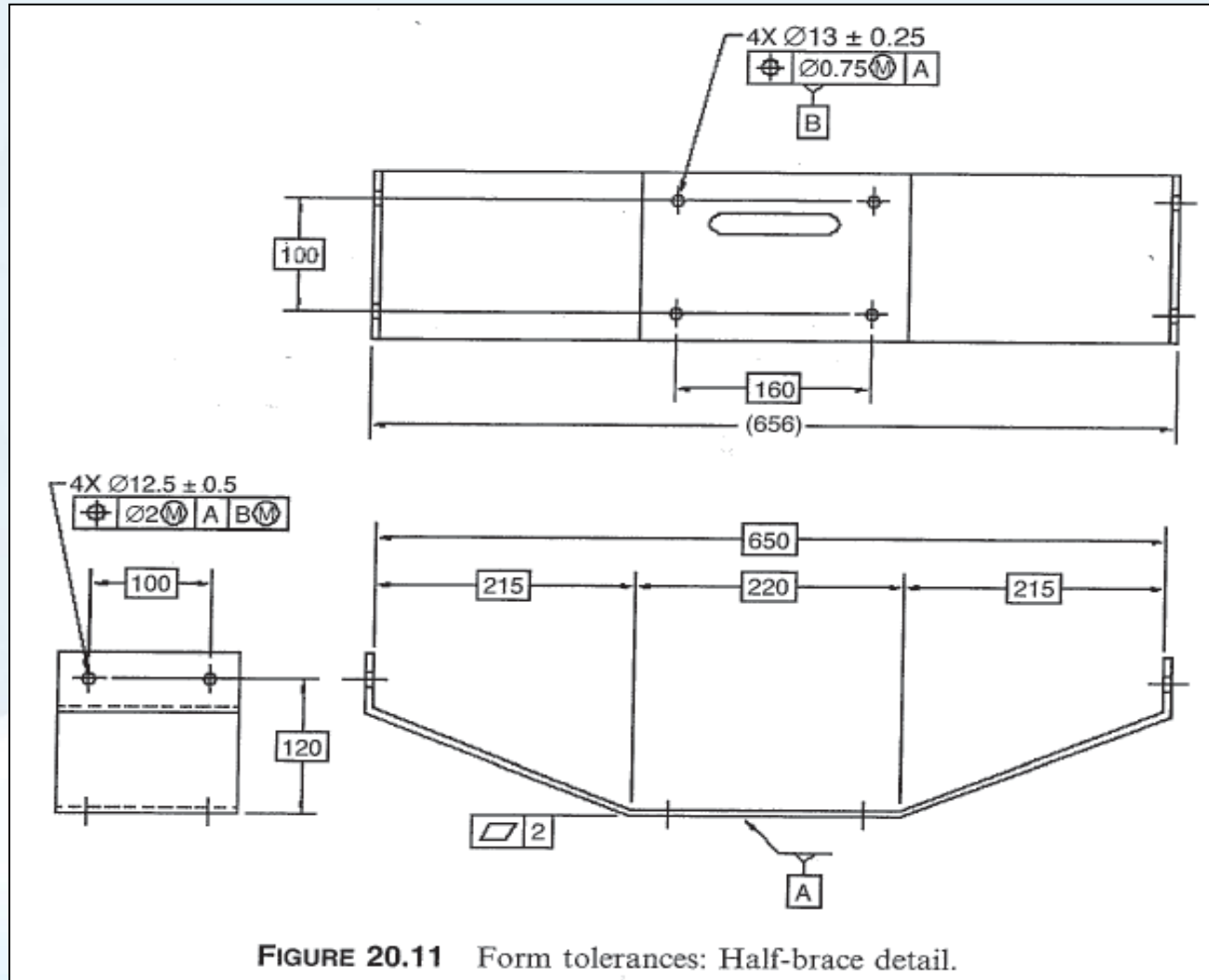
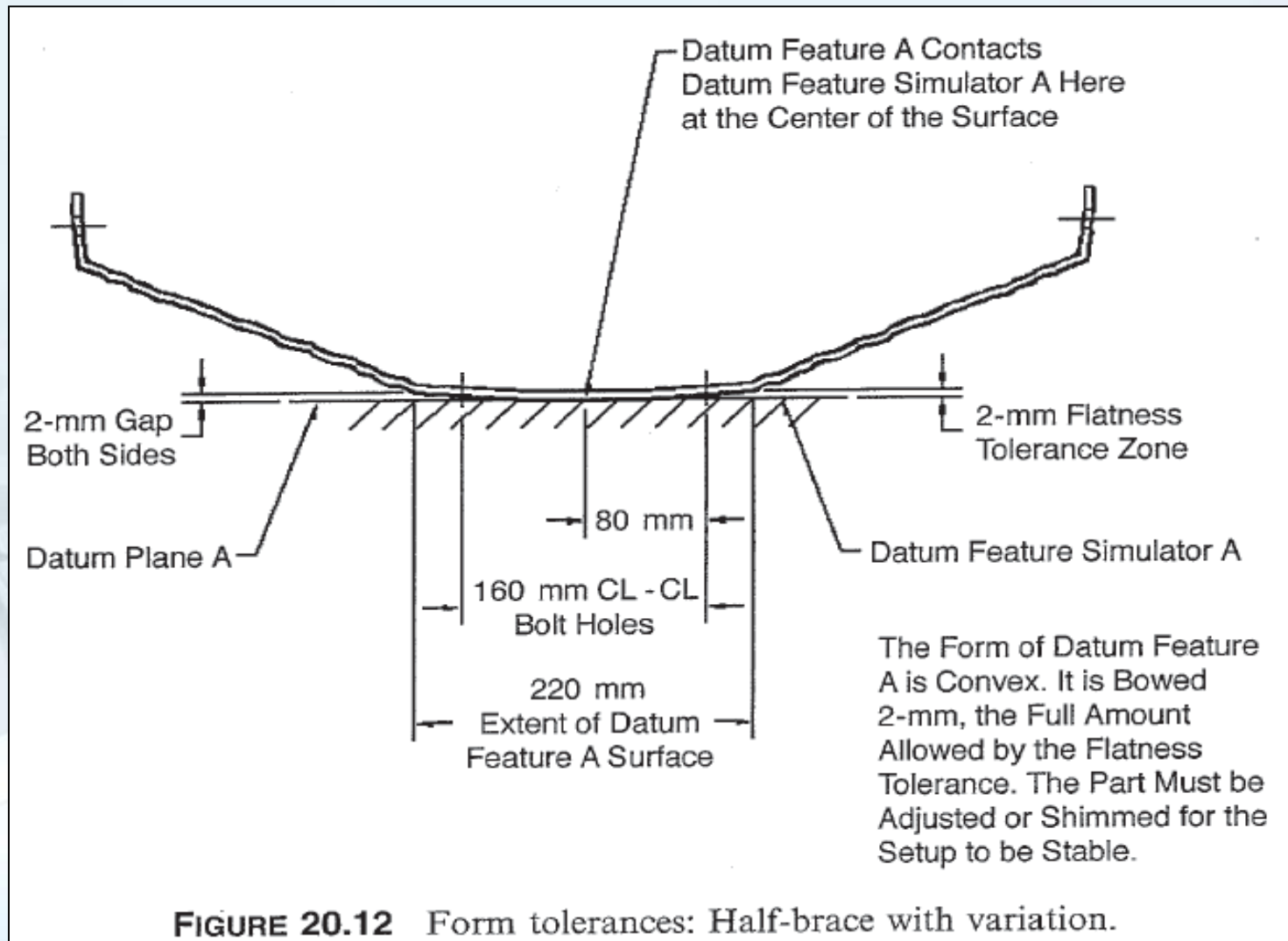
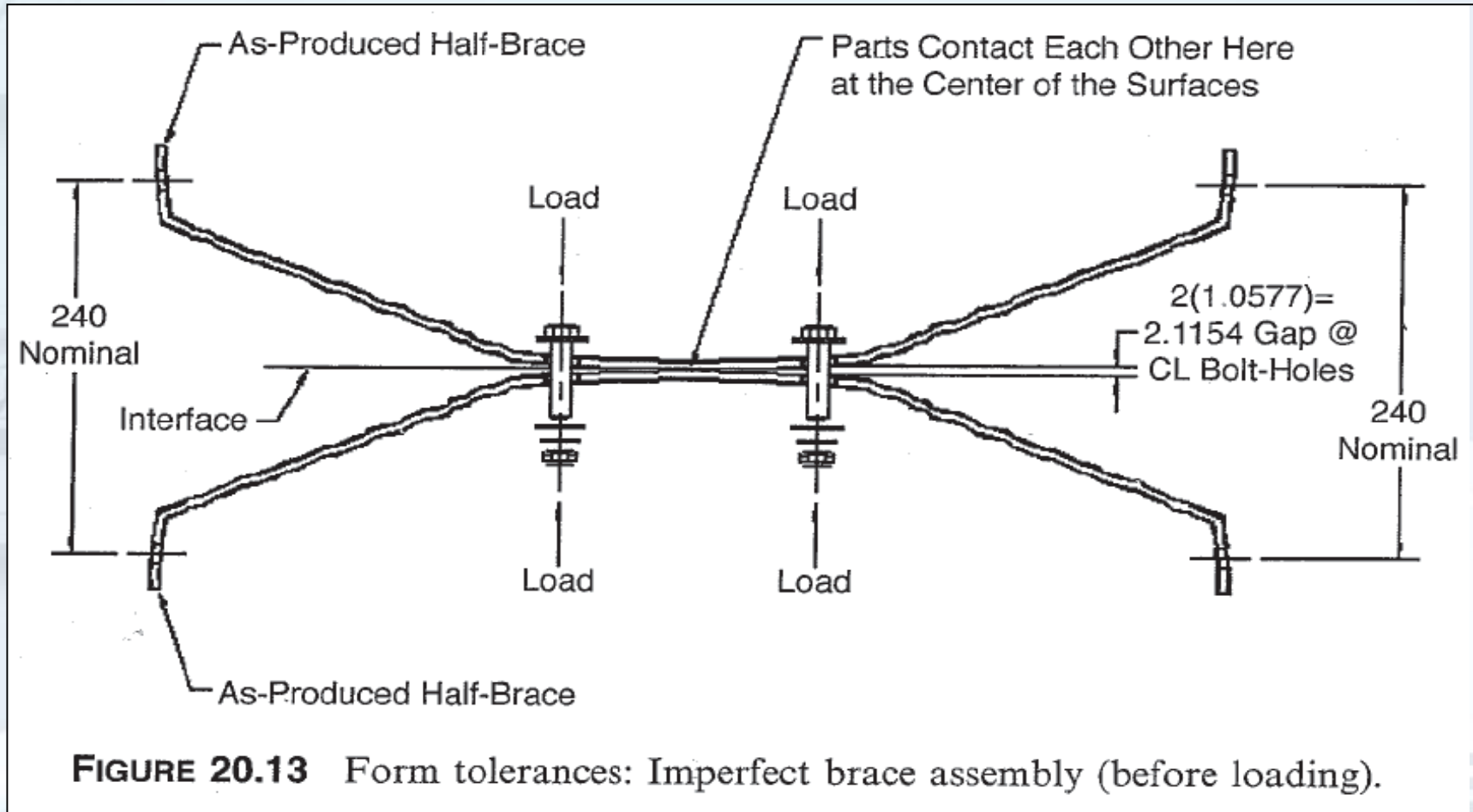

FIGURE 20.11 Form tolerances: Half-brace detail.

## Form Tolerances Treated As Adding Rotational Variation



Form Tolerances Treated As Adding Rotational Variation





Form Tolerances Treated As Adding Rotational Variation

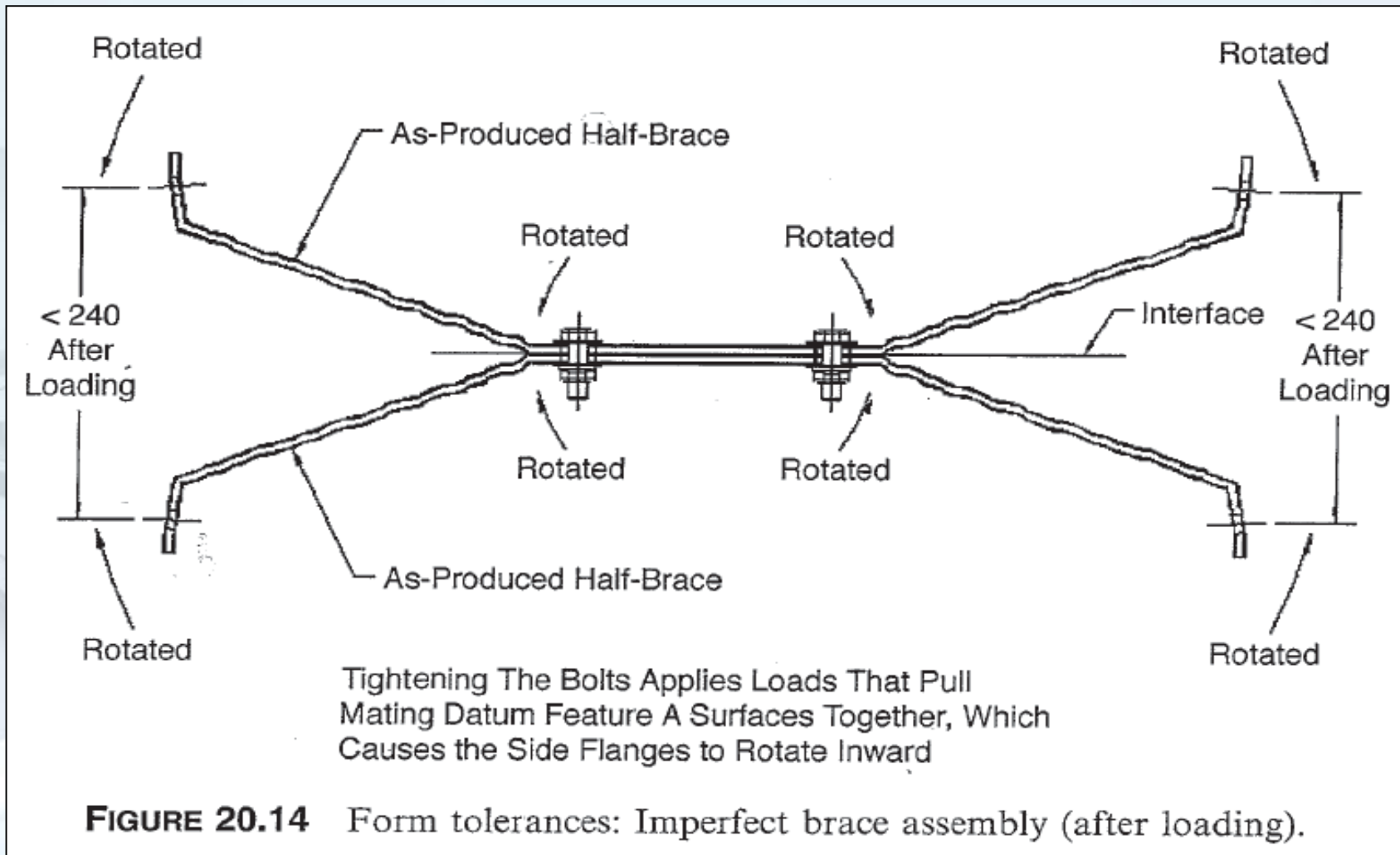

Form Tolerances Treated As Adding Rotational Variation

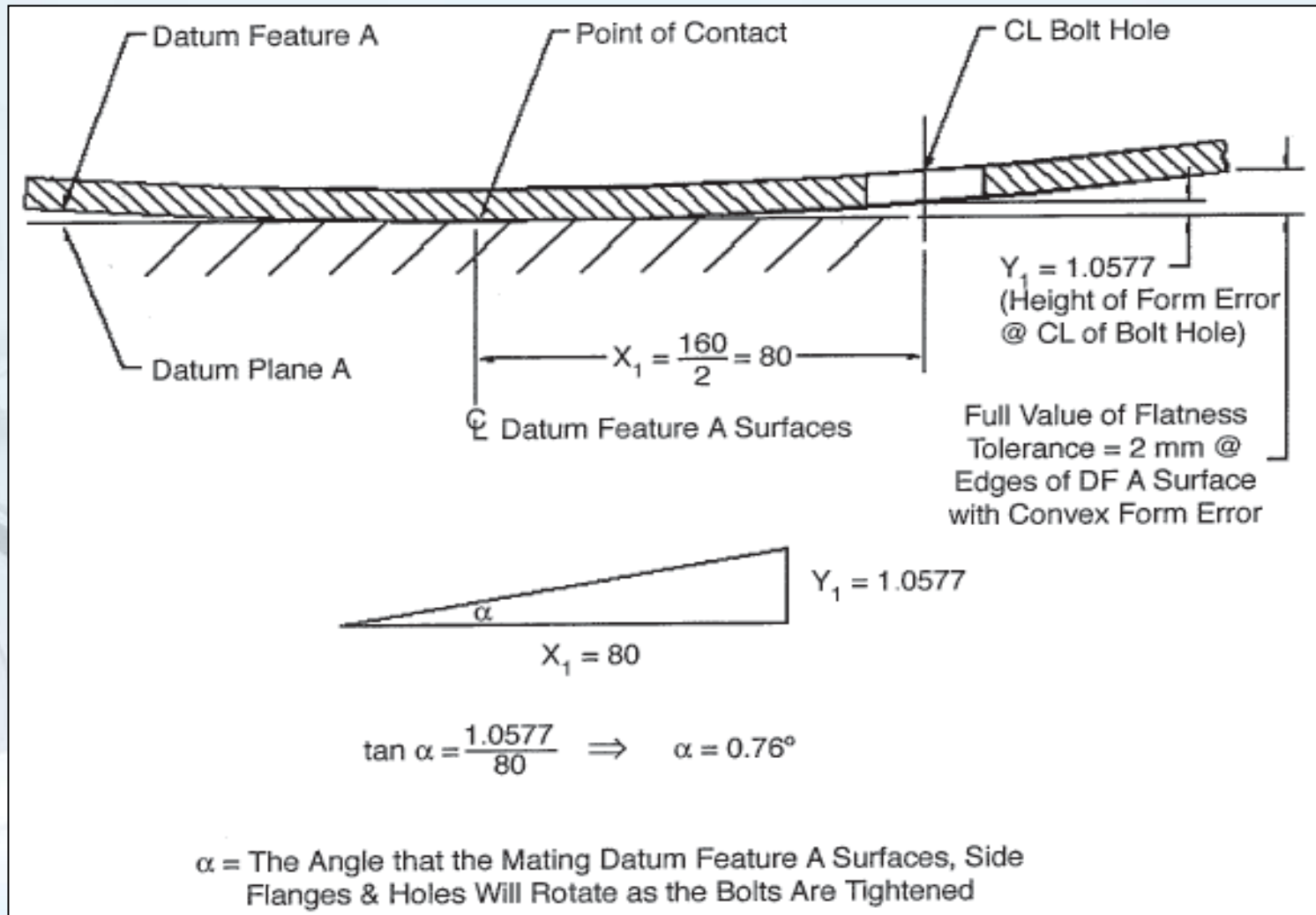

Form Tolerances Treated As Adding Rotational Variation

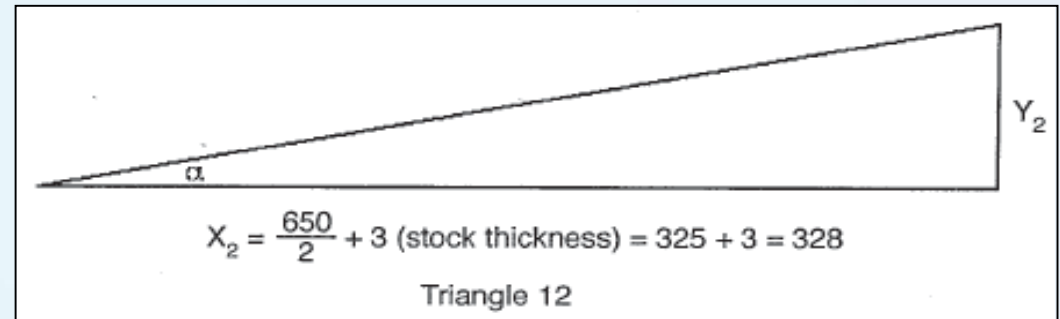
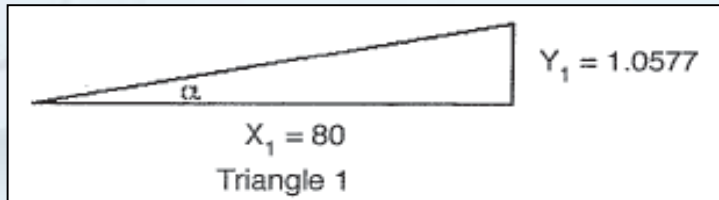

Solve For  $Y_2$ :

$$\frac{Y_1}{X_1} = \frac{Y_2}{X_2} \Rightarrow \frac{1.0577}{80} = \frac{Y_2}{328}$$

$$Y_2 = 1.0577(328/80) = 4.34$$

Note:

$Y_1$  is less than the full 2-mm value of the Flatness tolerance. With convex form error, the vertical variation of the Datum Feature A surfaces is only 1.0577 at the centerline of the bolt holes. It is assumed that the bolt forces will pull the surfaces together along the CL of the bolts.

**FIGURE 20.16** Form tolerances: Like triangles projecting the rotation out to the side flanges.

## Form Tolerances Treated As Adding Rotational Variation

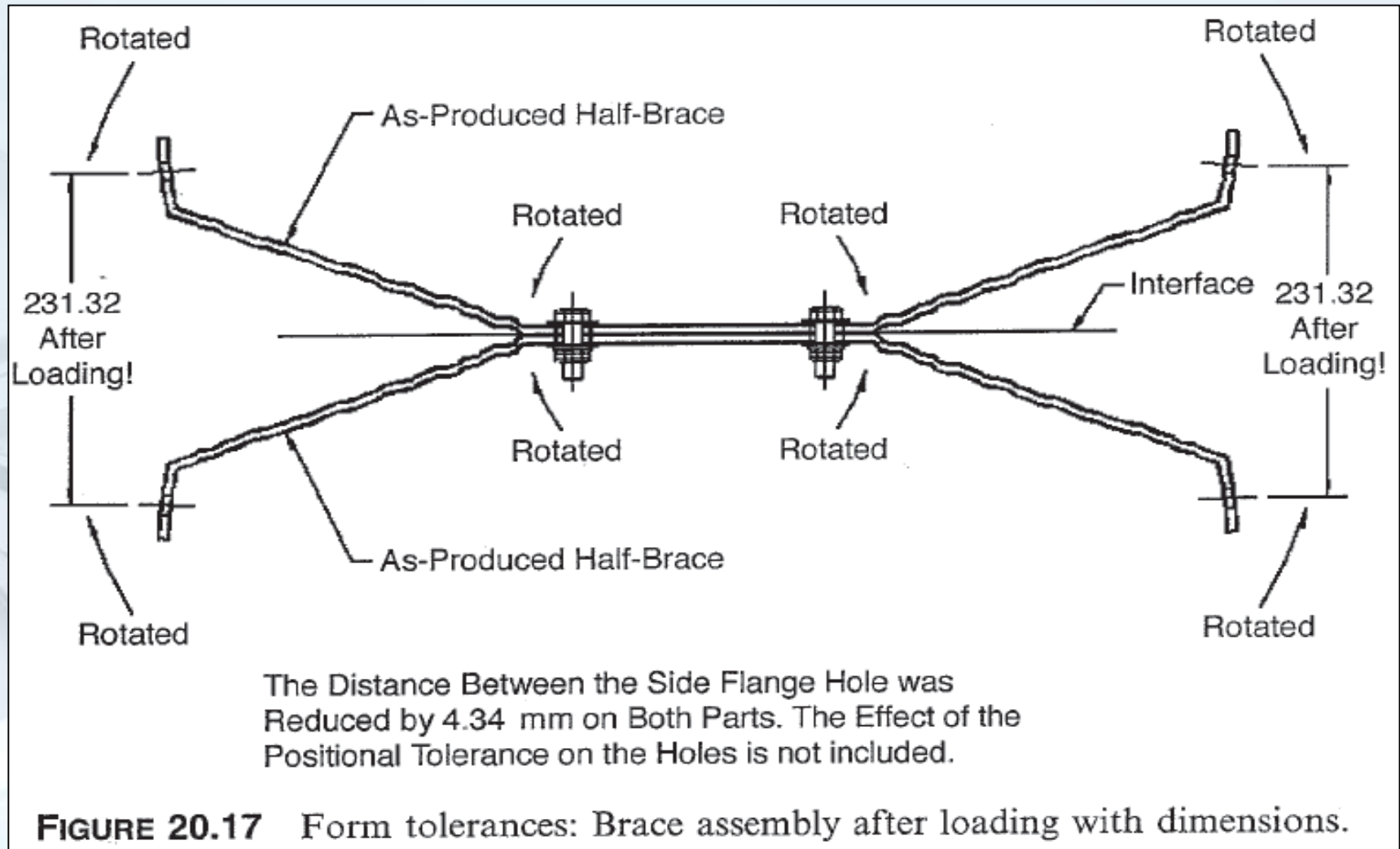

Form Tolerances Treated As Adding Rotational Variation

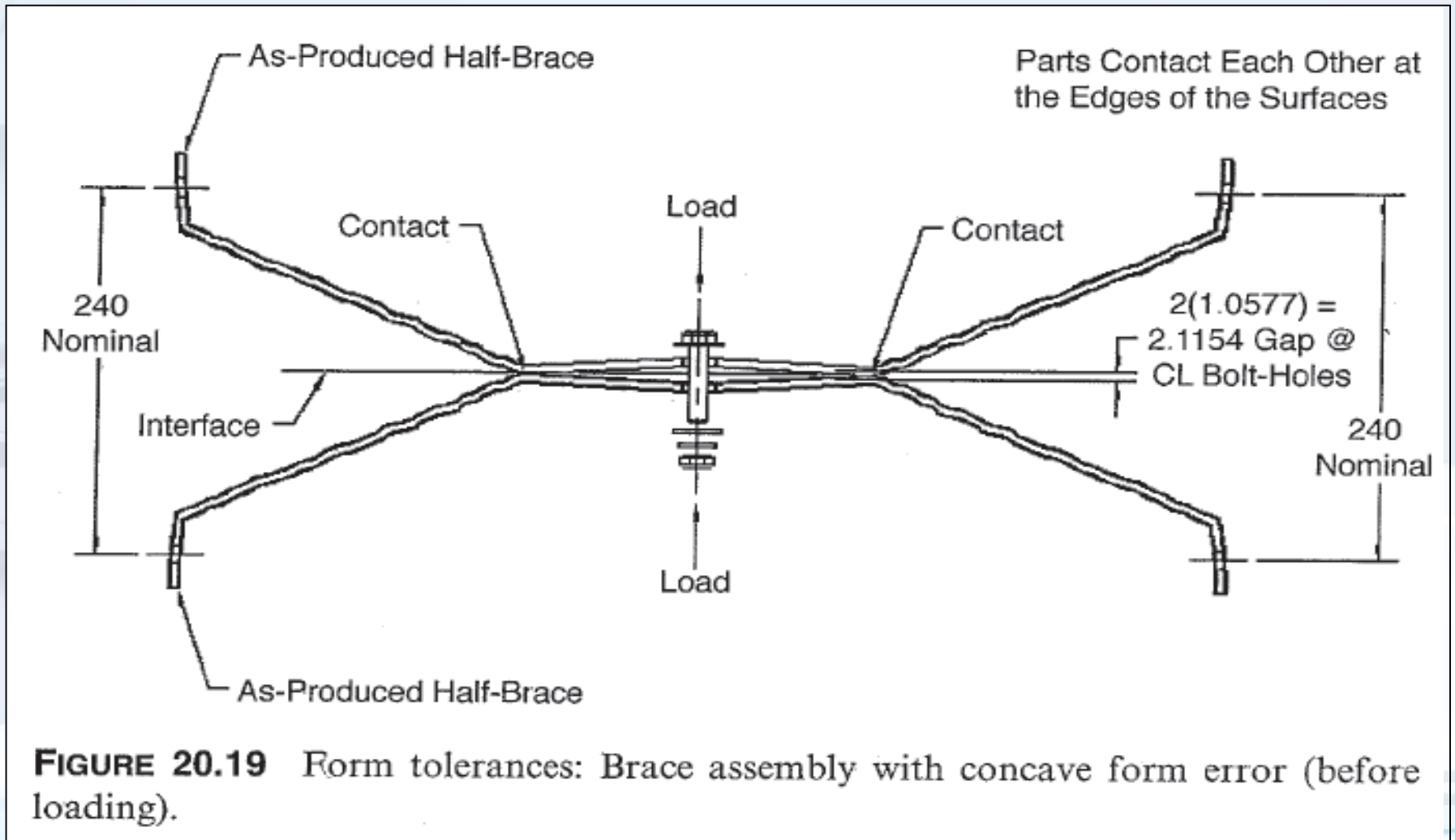



## Form Tolerances Treated As Adding Rotational Variation

Tolerance Stack										Release 1.2a
Program: Tolerance Analysis Textbook						<u>Stack Information:</u>				
Product: <u>Part Number</u> <u>Rev</u> <u>Description</u> FT9      A      Sample Assembly for Form Tolerance Chapter with Linear Displacement from Rotational Variation						Stack No: Figure 20.32				
Problem: When Bolts are Tightened Datum Feature A Surfaces will Deform and The Side Flange Bolt Holes will Be Displaced						Date: 07/04/02				
Objective: Determine the Variation Between the Holes in The Side Flanges in the Vertical Direction						Revision: A				
						Direction: Vertical				
						Author: BR Fischer				
Description of Component / Assy	Part Number	Rev	Item	Description	+ Dims	- Dims	Tol	Percent Contrib	Dim / Tol Source & Calcs	
Half-Brace (Upper Part)	FT11	A	1	Position: Holes in Upper Side Flanges			± 1.0000	9%	Position dia 2 @ MMC, A, B @ MMC	
			2	Bonus Tolerance			± 0.5000	4%	= (0.5 + 0.5)/2	
			3	Datum Feature Shift:				0%		
			4	Dim: CL Side Flange Holes - Datum A	120.0000		± 0.0000	0%	N/A - DF <sub>A</sub> Shift is Perpendicular to Tolerance Stackup	
			5	Flatness Tolerance (Datum Feature A)			± 4.3400	37%	120 Basic on Dwg	
Half-Brace (Lower Part)	FT11	A	6	Flatness Tolerance (Datum Feature A)			± 4.3400	37%	Flatness 1 on Dwg - 4.34 Projected (See Notes)	
			7	Dim: Datum A - CL Side Flange Holes	120.0000		± 0.0000	0%	Flatness 1 on Dwg - 4.34 Projected (See Notes)	
			8	Position: Holes in Upper Side Flanges			± 1.0000	9%	120 Basic on Dwg	
			9	Bonus Tolerance			± 0.5000	4%	Position dia 2 @ MMC, A, B @ MMC	
			10	Datum Feature Shift:			± 0.0000	0%	= (0.5 + 0.5)/2	
Dimension Totals					240.0000	0.0000				
Nominal Distance: Pos Dims - Neg Dims =					240.0000					
<b>RESULTS:</b>					Nom	Tol	Min	Max		
Arithmetic Stack (Worst Case)					240.0000	± 11.6800	228.3200	251.6800		
Statistical Stack (RSS)					240.0000	± 6.3381	233.6619	246.3381		
Adjusted Statistical: 1.5*RSS					240.0000	± 9.5071	230.4929	249.5071		
<u>Notes:</u>										
- The Flatness Tolerance Specified for Datum Feature A on Both Parts is included in the Tolerance Stackup.										
<u>Assumptions:</u>										
- It is assumed that the form error allowed by the Flatness tolerances specified for both Datum Feature A Surfaces allows the surfaces to rotate when the bolts are tightened. When the Bolts are tightened, the Datum Feature A surfaces will deform and rotate until the surfaces meet along the nominal interface. The Datum Feature A surfaces are assumed to rotate to close the gap between them. This rotation is projected out to the Side Flanges, which rotate through the same angle. Both parts are subject to the same deformation as the Bolts are tightened, so both the effect of both Flatness tolerances are included in the Tolerance Stackup. The Form tolerances are assumed to act equally in both the positive and negative directions, making the distance between the holes either larger or smaller.										
<u>Suggested Action:</u>										
- Add a note to the Half-Brace detail drawing to inspect the part with forces applied. The forces should approximate the forces encountered at assembly; this will negate most of the effect of the projected Form error.										



### Form Tolerances Treated As Adding Rotational Variation

- Determining whether to treat the form tolerance as adding translational or rotational variation and how to include it in the
- Tolerance Stack up presents us with a problem. There are four things to consider:
  - Whether form tolerances should be included in the Tolerance Stack up.
  - Whether the variation allowed by form tolerances should be treated as translation or as rotation.
  - How to include the form tolerances in the Tolerance Stack up.
  - How to quantify the potential effect of the form tolerances.

### Form Tolerances Treated As Adding Rotational Variation

- Generally speaking, form tolerances are less likely to add translational error than rotational error to a Tolerance Stack up.
- It is possible to solve the Tolerance Stack up twice if desired, by treating the allowable form error as translational in one study and rotational in another.

# THANK YOU

## Are there any Questions?

QUALITY

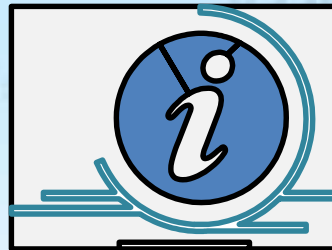

[Info-in@omnex.com](mailto:Info-in@omnex.com)



**OMNEX**  
[WWW.OMNEX.COM](http://WWW.OMNEX.COM)