

# Product Knowledge Document

## COOLING SYSTEM & CAR RADIATORS

QUALITY



**© 2013, Omnex, Inc.**  
**325 E. Eisenhower Parkway, Suite 4**  
**Ann Arbor, MI 48108**  
**(734) 761-4940**

*This publication is protected by Federal Copyright Law, with all rights reserved. No part of this publication may be reproduced, stored in a retrieval system, translated, transcribed, or transmitted, in any form, or by any means manual, electronic, electro-magnetic, mechanical, chemical, optical, or otherwise, without prior explicit written permission from Omnex, Inc.*



**Omnex provides training, consulting and software solutions to the international market with offices in the USA, Canada, Mexico, Latin America, Germany, China (PRC), India, the Middle East and Thailand.**

**Omnex offers over 200 training workshops in business, quality, environmental, laboratory, health & safety management systems and Lean Six sigma worldwide.**

**Internet email: [info@omnex.com](mailto:info@omnex.com)**

**Web: [www.omnex.com](http://www.omnex.com)**



# INTRODUCTION

## HISTORY OF ENGINE COOLING AND RADIATOR

- Heat dissipation is probably one of the most important considerations in engine design.
- An internal combustion engine creates enough heat to destroy itself.
- Without an efficient cooling system, we would not have the vehicles we do today.
- The original radiators were simple networks of round copper or brass tubes that had water flowing through them by convection.
- By the 1920's some auto manufacturers, like GM, had switched to oval tubes because they were slightly more efficient.
- Not long after that, as engines grew larger and hotter, companies began to add fans for a constant flow of air over the radiator cores.
- These more efficient cooling systems eventually added a pump to push the water through the cooling tubes.
- All in all, the car radiator is a simple and lasting technology that will likely be around as long as we use internal combustion engines.

# INTRODUCTION

A system, which controls the engine temperature, is known as a cooling system.

**The cooling system is provided in the IC engine for the following reasons:**

- The temperature of the burning gases in the engine cylinder reaches up to 1500 to 2000°C, which is above the melting point of the material of the cylinder body and head of the engine. (Platinum, a metal which has one of the highest melting points, melts at 1750 °C, iron at 1530°C and aluminum at 657°C.)



# INTRODUCTION

**The cooling system is provided in the IC engine for the following reasons: (Cont..)**

- Due to very high temperatures, the film of the lubricating oil will get oxidized, thus producing carbon deposits on the surface. This will result in piston seizure.
- Due to overheating, large temperature differences may lead to a distortion of the engine components due to the thermal stresses set up.
- Higher temperatures also lower the volumetric efficiency of the engine.

**If the heat is not dissipated, it would result in the failure of the cylinder material.**

**This makes it necessary for, the temperature variation to be kept to a minimum.**

# PURPOSE OF A COOLING SYSTEM AND RADIATOR

- In normal operation produces heat is generated as an output, this must be carried away by coolant
- Cooling system transfers heat to cooler and then to outside air when engine is hot.
- Cooling system keeps heat in the engine, when engine is not warm enough.
- Modern cooling systems are designed to maintain an even temperature of about 180 to 230°F (82 to 113°C).



# PURPOSE OF A COOLING SYSTEM AND RADIATOR

**The two main requirements of an efficient cooling system are:**

- It must be capable of removing only about 30% of the heat generated in the combustion chamber. Too much removal of heat lowers the thermal efficiency of the engine.
- It should remove heat at a fast rate when the engine is hot. During the starting of the engine, the cooling should be very slow so that the different working parts reach their operating temperatures in a short time.



# WATER COOLING SYSTEM

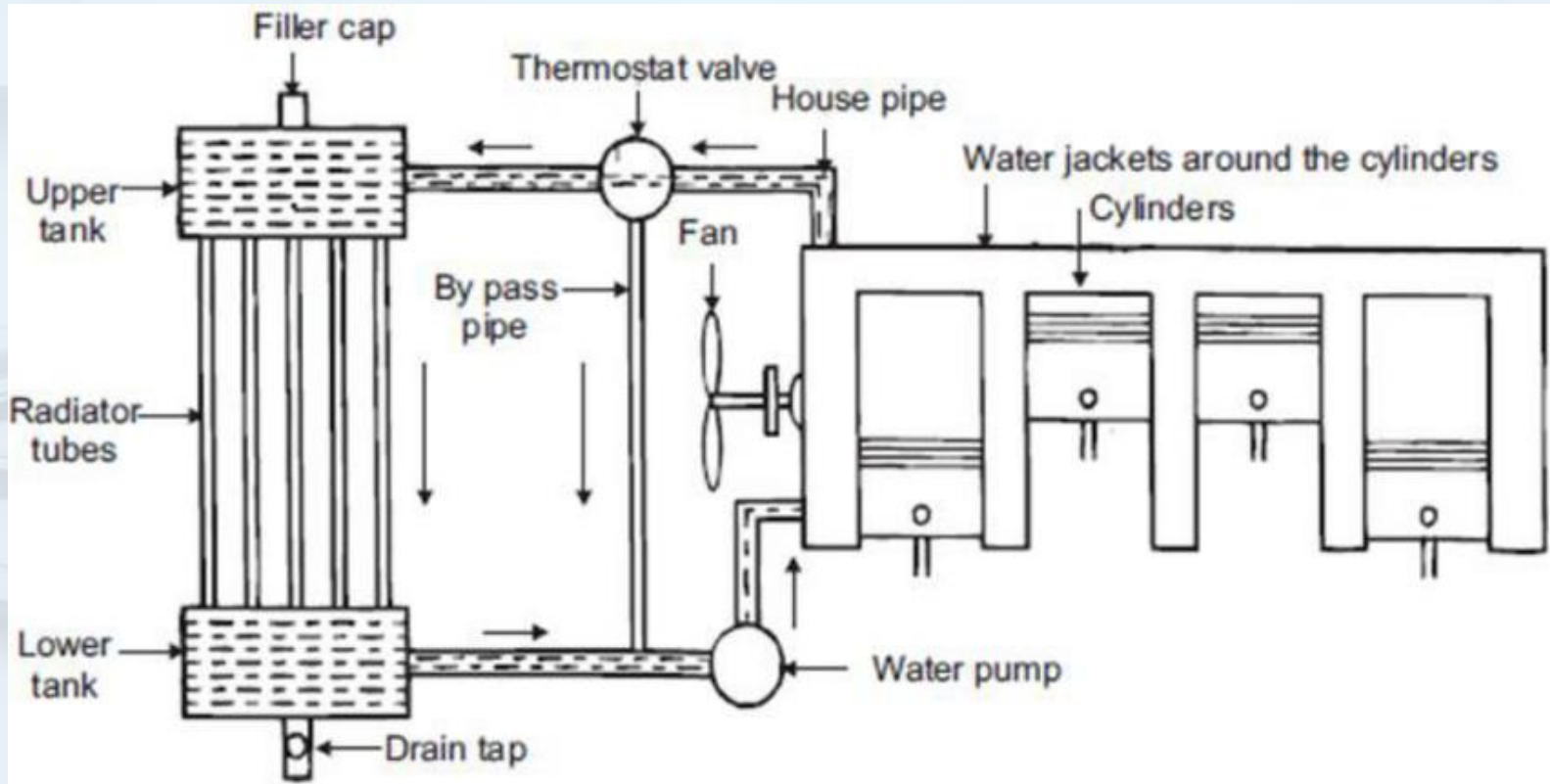

# COMPONENTS OF A WATER COOLING SYSTEM

## • COOLING SYSTEM MAIN COMPONENTS

- Water Pump
- Cooling Fan
- Radiator
- Pressure Cap
- Thermostat
- Clamps and hoses
- Overflow tank
- Coolant Reservoir
- Heater Core

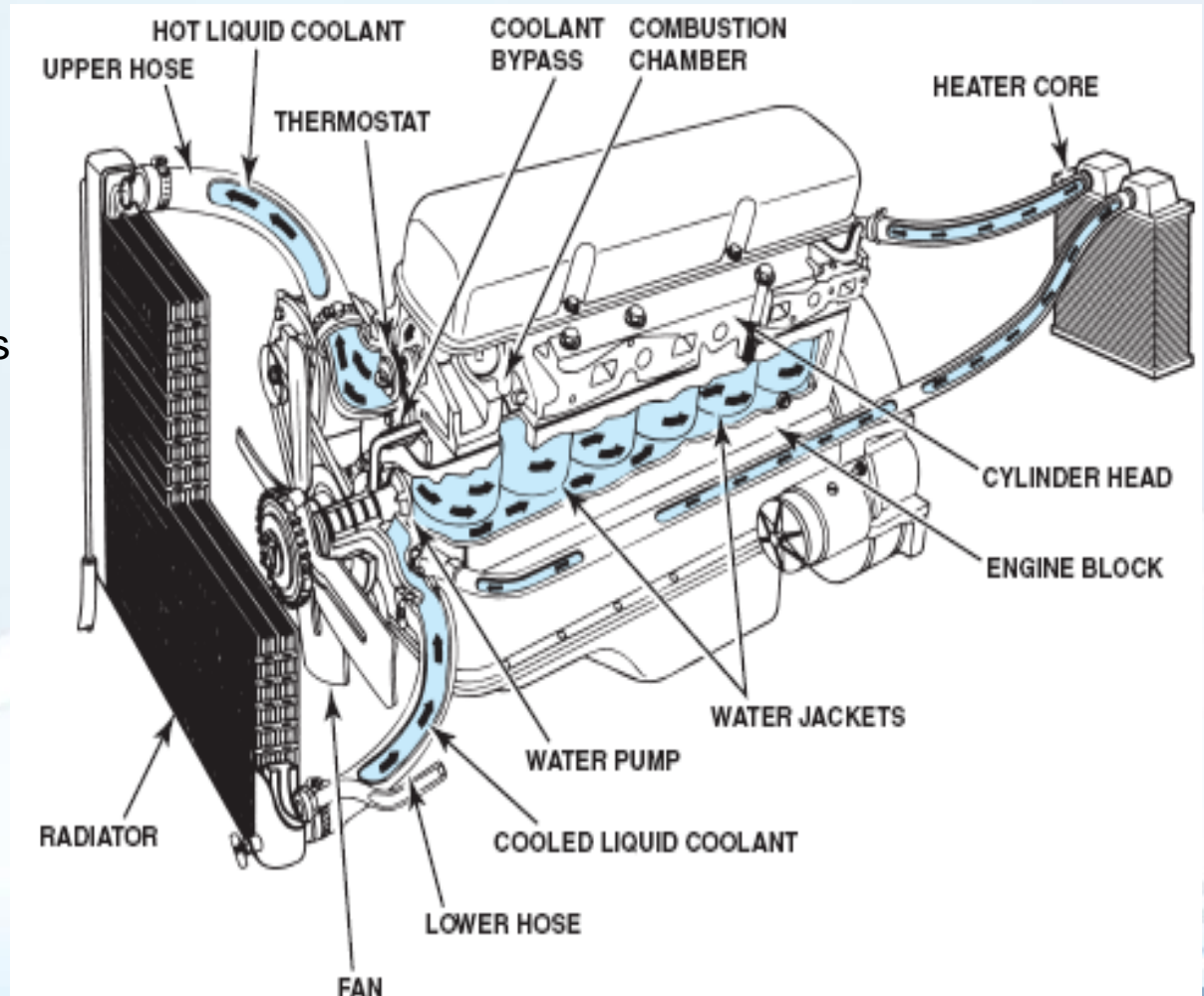

# COOLING SYSTEM OPERATION CYCLE

## 1. Heat generation ( As an output of operation process of engines)

Heat is generated by combustion inside the engine, some of the heat is carried away along with the exhaust gas. The remaining heat is absorbed by the engine itself there by increasing its temperature

## 2. Circulation Of Coolant using water pump

When the engine is started, the **water pump** connected to it also begins to pump the coolant around the engine cylinder from the lower radiator tank into the coolant passage/ **water jackets**. The flow of coolant is from the lower tank to engine block then to cylinder head and finally towards the outlet for **radiator**.

## 3. Heat Transfer to Coolant

Coolants begins to absorb the heat produced by the combustion process and flows towards the **radiator inlet**, thereby reducing the temperature of the engine.

# COOLING SYSTEM OPERATION STEPS

## 4. Coolant Flow control at inlet of Radiator

The Thermostat restricts the coolant to flow towards the radiator until the temperature of coolant is not raised above the engine operating temperature which is usually 200-250°C

## 5. Heat Transfer from Coolant to heater Core

At this instance if the heater inside the vehicle cabin/ passenger compartment is turned ON, the coolant is made to flow through the heater core via bypass hose.

Here the Heater Core acts like a mini radiator, which is used as a heat exchanger to transfer the heat from the coolant to the air that flows inside the passenger compartment

# COOLING SYSTEM OPERATION STEPS

## 6. Circulation of coolant to radiators via thermostat

The **thermostat**, acts like a regulating valve to control the coolant flow into the radiator and maintain the engine temperature within optimum range. When temperature of the coolant increases beyond the operating temperature of the engine (Usually 180 F) the thermostat open and the coolant flows towards the **Radiator**.

## 7. Heat transfer from coolants to radiators and then to atmosphere

**Fan** is actuated by the thermostatic switch once the coolant flows outside the thermostat. This helps in circulating the air in contact with the radiator. Coolant then enters into the radiator upper tank through the upper radiator hose. Coolant loses its heat to the air flowing past the **radiator**. Coolants with lower temperature now is again pumped back to the **water jackets**.

# COOLING SYSTEM OPERATION STEPS

## 8. Pressure release in case of high pressure created in the upper tank

Due to high temperature there are chances of building up of high pressure that might block the coolant from entering into the upper tank, to avoid this the upper tank is provided with a **pressure regulating valve**, which opens when the pressure in the system increases beyond the recommended value and the opening allows the high pressurized coolants to flow into overflow tank.

# COMPONENTS OF COOLING SYSTEM

# COMPONENTS OF A WATER COOLING SYSTEM

- **COOLING SYSTEM MAIN COMPONENTS**

- Water Pump
- Radiator
- Thermostat
- Cooling Fan
- Clamps and hoses
- Pressure Cap
- Overflow tank
- Coolant Reservoir
- Heater Core

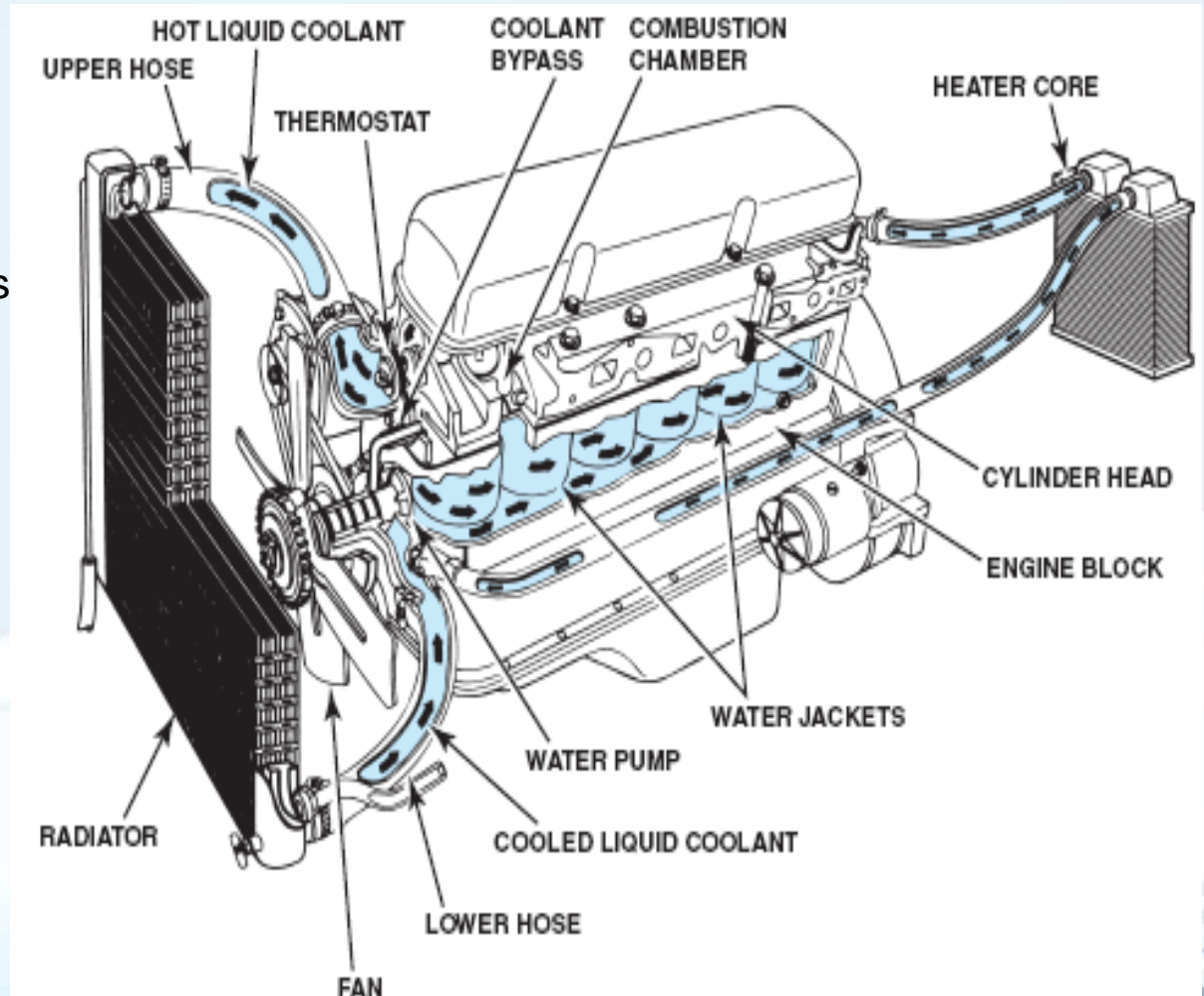



# WATER PUMPS

- This is a centrifugal type pump.
- It is centrally mounted at the front of the cylinder block and is usually driven by means of a belt.
- This type of pump consists of the following parts:
  1. Body or casing,
  2. Impeller (rotor),
  3. Shaft,
  4. Bearings, or bush,
  5. Water pump seal
  6. Pulley.
- The bottom of the radiator is connected to the suction side of the pump.
- The power is transmitted to the pump spindle from a pulley mounted at the end of the crankshaft.
- Water pumps can be driven off of the serpentine belt, the timing belt, or the camshaft.
- Seals of various designs are incorporated in the pump to prevent loss of coolant from the system.

# WATER PUMPS

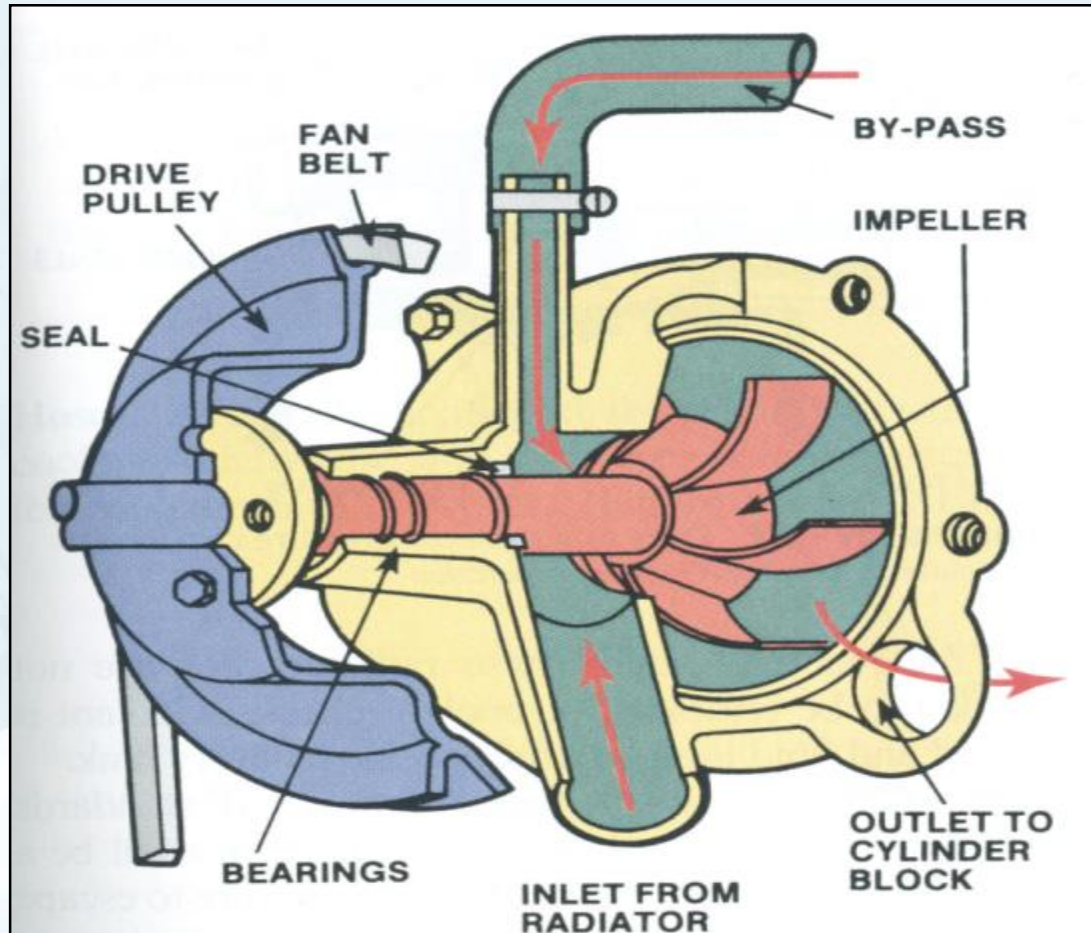

# WATER JACKETS

- When an engine cylinder block and head are cast, cavities called water jackets are formed around the cylinder walls and combustion chambers.
- These water jackets allow coolant to circulate around the very hot areas, including the exhaust valve seats, as well as the relatively cooler areas of the lower cylinders.
- The coolant absorbs heat from the hot areas and transfers this heat to the colder areas in the engine or radiator.
- The circulation of the coolant through water jackets are made possible using the water pump

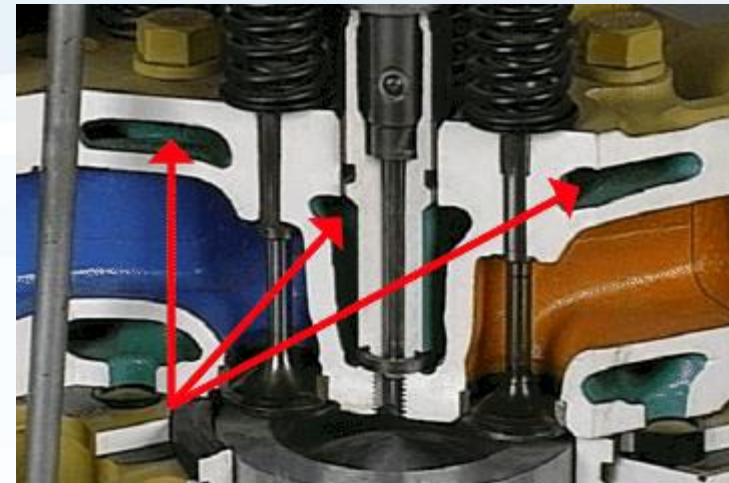

# THERMOSTAT

## Functions of Thermostat

- It is a kind of check valve which opens and closes with the effect of temperature.
- Speeds up engine warm up
- Regulates flow and temperature of engine coolant.
- Maintains optimum engine operating temperature for best emissions and economy.



# THERMOSTAT

## Thermostat Temperature

Thermostat temperature is the opening temperature

Thermostat should be fully open 20°F above opening temperature

195°F thermostat = fully open at 215°F

180°F thermostat = fully open at 200°F



## Thermostat Operations

- During the warm-up period, the thermostat is closed and the water pump circulates the water only throughout the cylinder block and cylinder head.
- Most are on the outlet side of coolant flow.

# THERMOSTAT

## Thermostat Operations

- The thermostat contains a wax pellet on the engine side of the thermostat. (Fig A)
- Wax melts and expands when engine heats up.
- As the wax expands, it overcomes spring pressure and opens the valve.(Fig B)

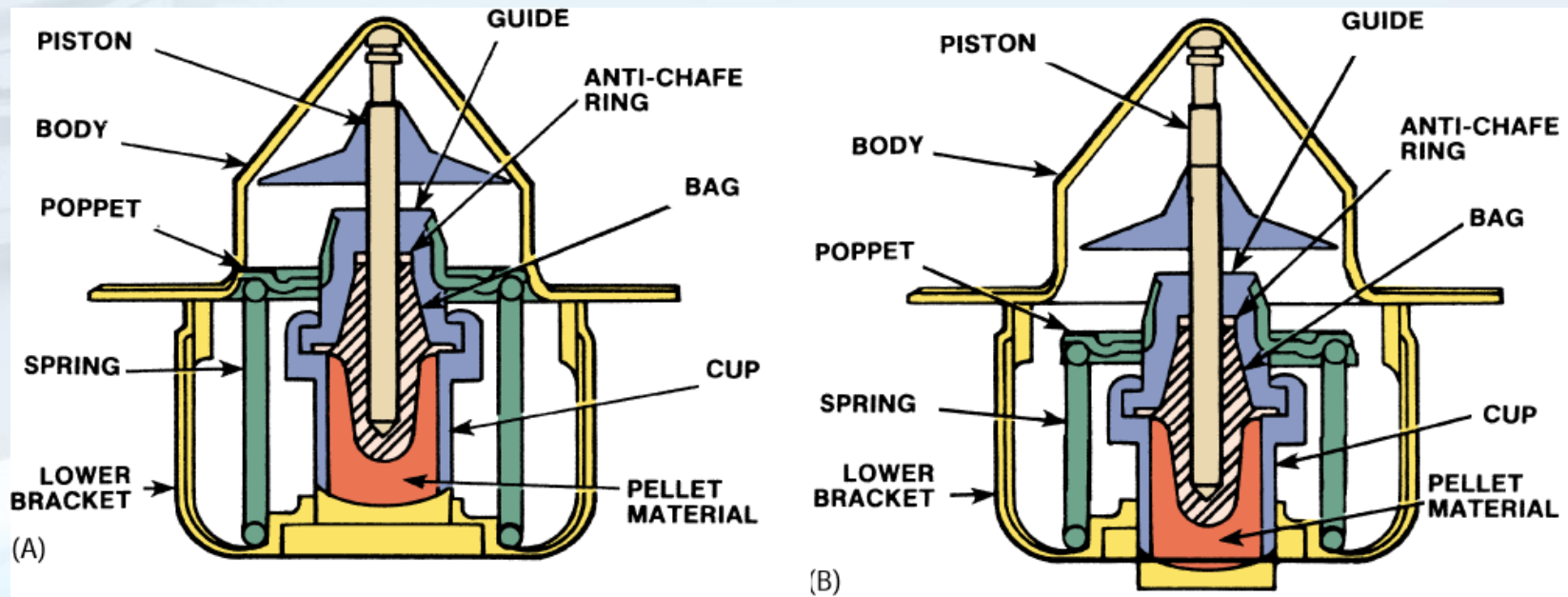

# THERMOSTAT

## Thermostat Types

- **Bellow type valve:** Flexible bellows are filled with alcohol or ether. When the bellows is heated, the liquid vaporizes, creating enough pressure to expand the bellows. When the unit is cooled, the gas condenses. The pressure reduces and the bellows collapse to close the valve.
- **Bimetallic type valve:** This consists of a bimetallic strip. The unequal expansion of two metallic strips causes the valve to open and allows the coolant to flow in the radiator.
- **Pellet type valve:** A copper impregnated wax pellet expands when heated and contracts when cooled. The pellet is connected to the valve through a piston, such that on expansion of the pellet, it opens the valve. A coil spring closes the valve when the pellet contracts.

# RADIATORS

- The purpose of the radiator is to cool down the coolant received from the engine.
- The radiator consists of three main parts:
  1. Upper tank
  2. Lower tank
  3. Tubes
- Hot coolant from the upper tank, which comes from the engine, flows downwards through the tubes. The heat contained in the hot coolant is conducted to the copper fins provided around the tubes.
- An overflow pipe, connected to the upper tank, permits excess water or steam to escape.



# RADIATORS

- **Types of Radiators**

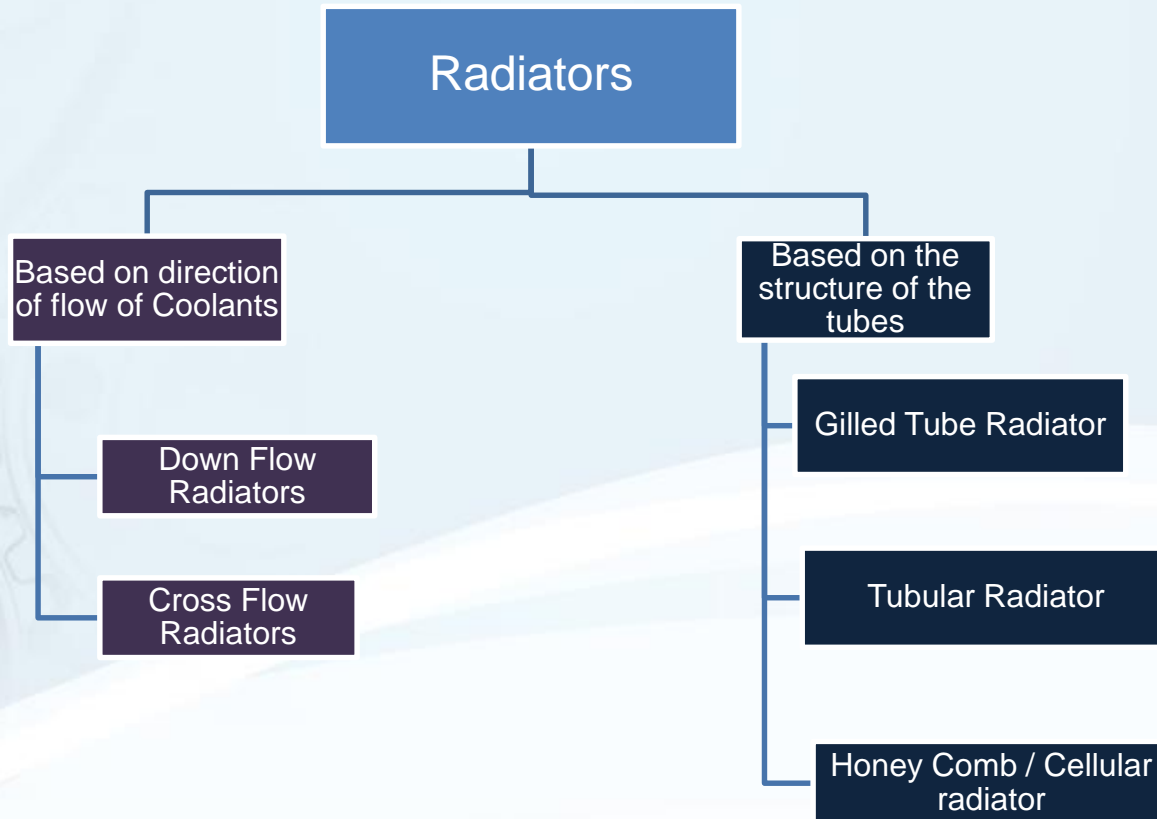

# RADIATORS

- Types of Radiators- Based on the direction of flow of coolants

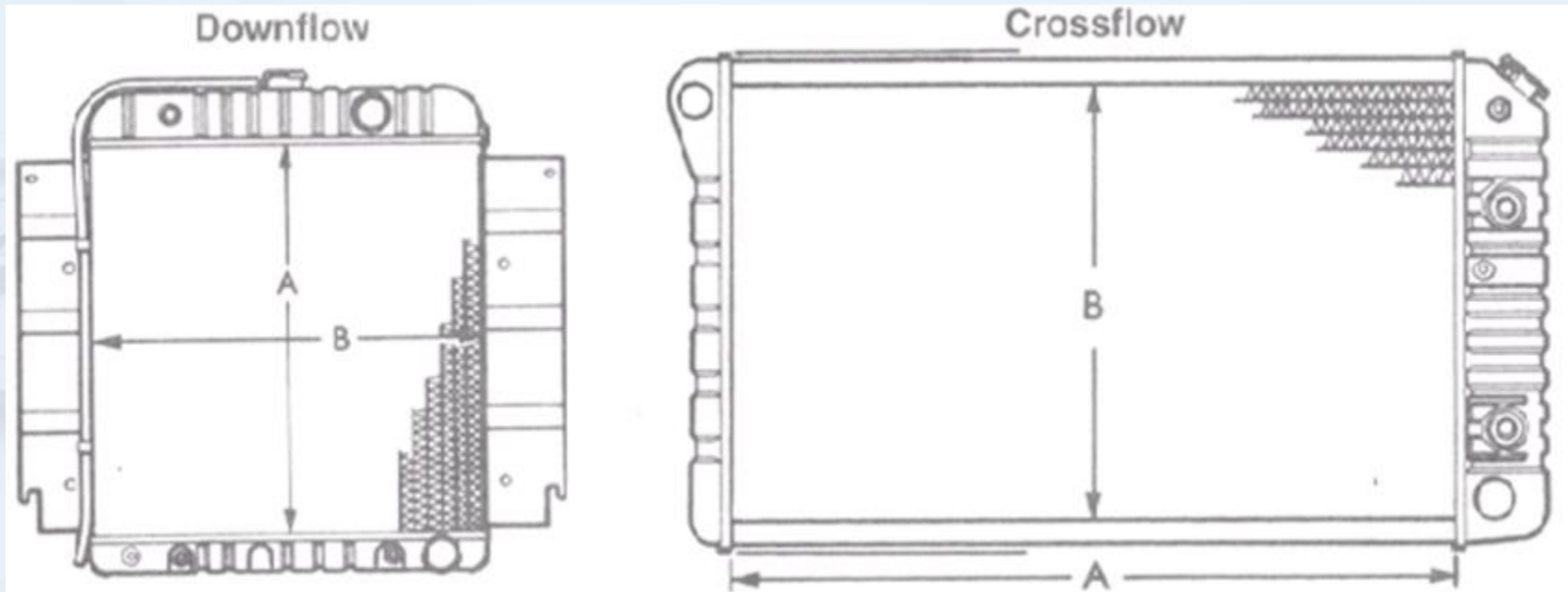

# RADIATORS

## Types of Radiators- Based on the structure of tubes

### Gilled tube radiator:

This is perhaps the oldest type of radiator, although it is still in use. In this, coolant flows inside the tubes. Each tube has a large number of annular rings or fins pressed firmly over its outside surface



# RADIATORS

## Types of Radiators- Based on the structure of tubes

### Tubular radiator:

The only difference between a gilled tubes radiator and a tubular one is that in this case there are no separate fins for individual tubes. The radiator vertical tubes pass through thin fine copper sheets which run horizontally.

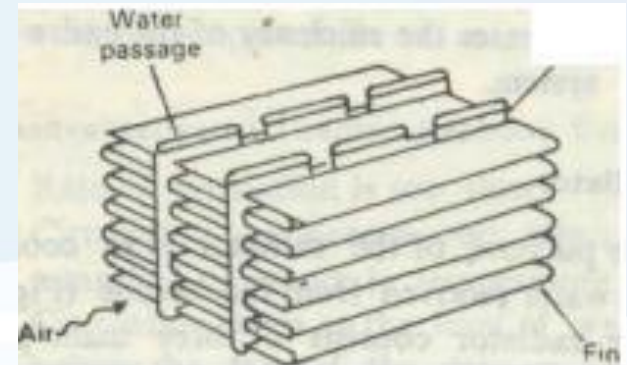

# RADIATORS

## Types of Radiators- Based on the structure of tubes

### Honey comb or cellular radiator:

The cellular radiator consists of a large number of individual air cells which are surrounded by water. In this, the clogging of any passage affects only a small parts of the cooling surface. However, in the tubular radiator, if one tube becomes clogged, the cooling effect of the entire tube is lost.

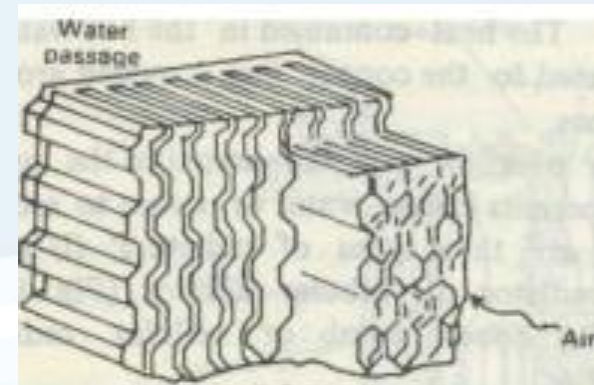

# COOLING FAN

- A **radiator cooling fan** is device that can help regulate engine temperature by pulling air through a **radiator**. Although a **cooling fan** can be necessary to prevent an engine from overheating, these **fans** aren't responsible for the majority of the **cooling** performed by **radiators**.
- There are primarily two types of engine radiator cooling fan:
  1. Electric Cooling Fan
  2. Manual Cooling Fan



# COOLING FAN

## Manual fan

- Connected to the engine drive pulleys and is controlled by a thermo fan clutch which senses radiator heat and engages when the engine is running at higher temperatures. These thermo reactive clutches are constructed to "freewheel" when not in use, and become connected using a silicone grease which expands when heated. This unit uses a set of shaft bearings and seal to retain lubricant and are normally bolted to the water pump of the engine.

# COOLING FAN

## Electric cooling fan:

- Primarily to boost engine performance and cut down on emissions.
- These fans are featured in both front and rear wheel drive vehicles and are activated by a coolant sensor via the computer.
- Using a sensor the computer detects that the engine temperature is rising above normal limits, a signal is sent to close the fan control relay which is protected by a circuit fuse.



# CLAMPS AND HOSES

- Hoses direct coolant from the engine to the radiator, heater core, and the overflow tank.
- Clamps hold hoses in place.

## CLAMPS

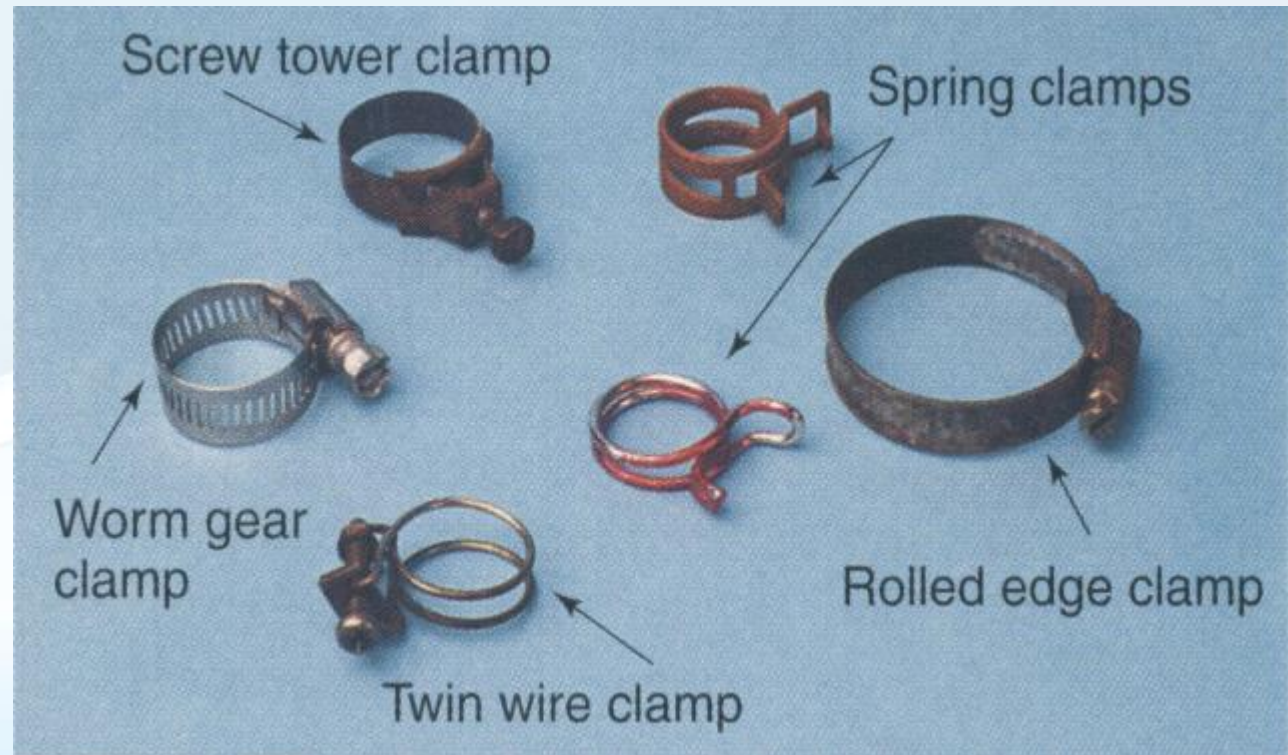

# CLAMPS AND HOSES

## Power Grip Clap

- Power Grip clamps are larger than the hose and must be heated to shrink and seal the hose.

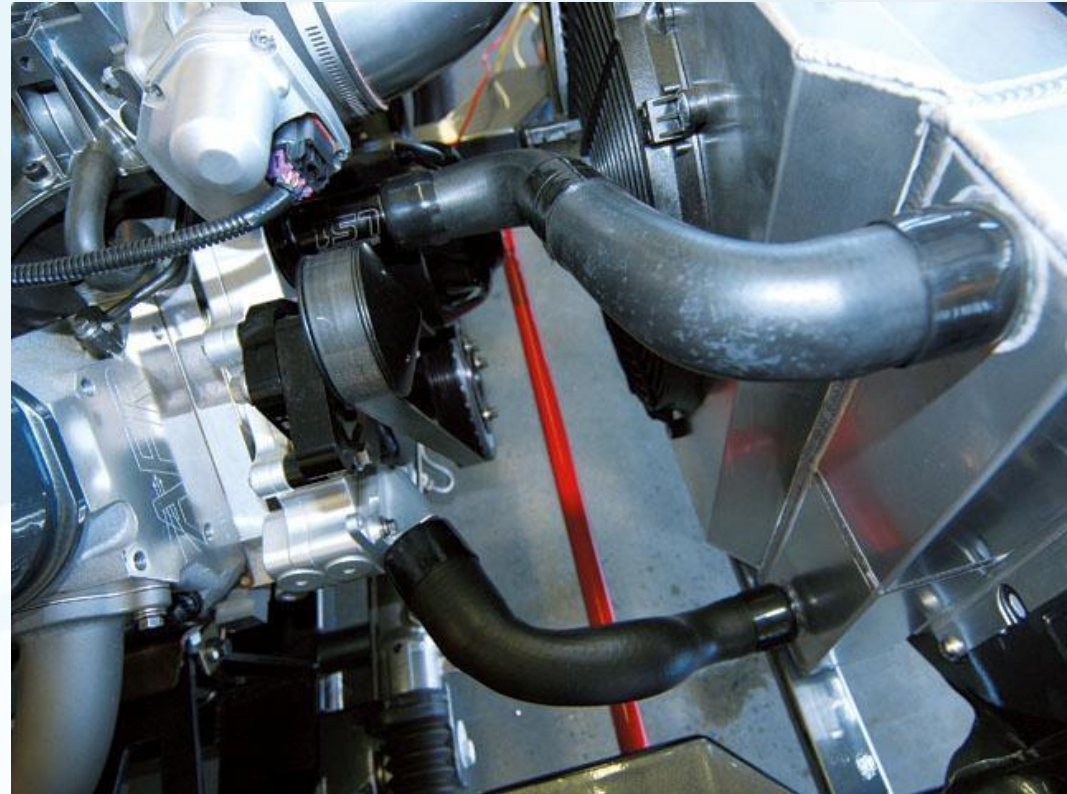

# PRESSURE CAP

The upper gasket prevents coolant from escaping to the outside. The lower gasket keeps a pressure in the radiator. The cam lock pushes the two gaskets against the sealing surfaces when the cap is installed. The safety stop prevents the cap from being opened too quickly.

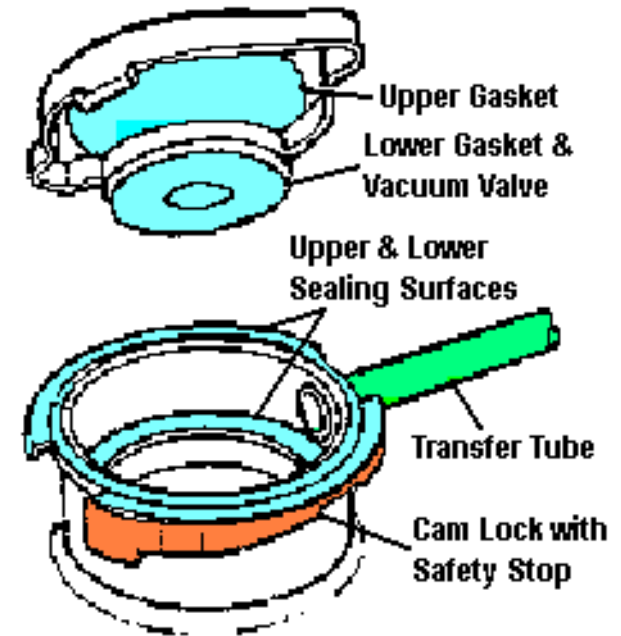

# PRESSURE CAP

**Normal Operation**

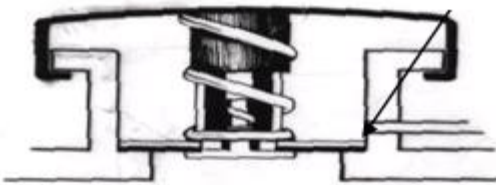

**Valves Closed**

**Excessive Pressure**

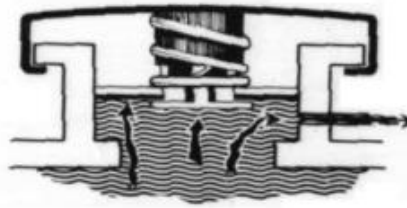

**Pressure Valve Open**

**Cooling-Off Period**

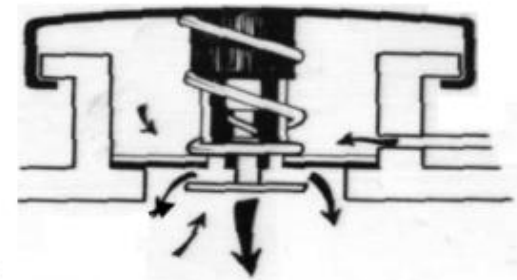

**Vacuum Valve Open**

# PRESSURE CAP

- Pressurizing a liquid increases the boiling point of that liquid.
- Cooling systems are pressurized so that the boiling point of the coolant is raised.
- Many cooling systems are pressurized to 15 psi.
- **The pressure cap allows the pressure to build, and release past a specified point.**
  - Equipped with Vacuum and Pressure Valve
  - Used to raise Pressure in system

The coolant's boiling point increases about 3° F for each psi increase in pressure.

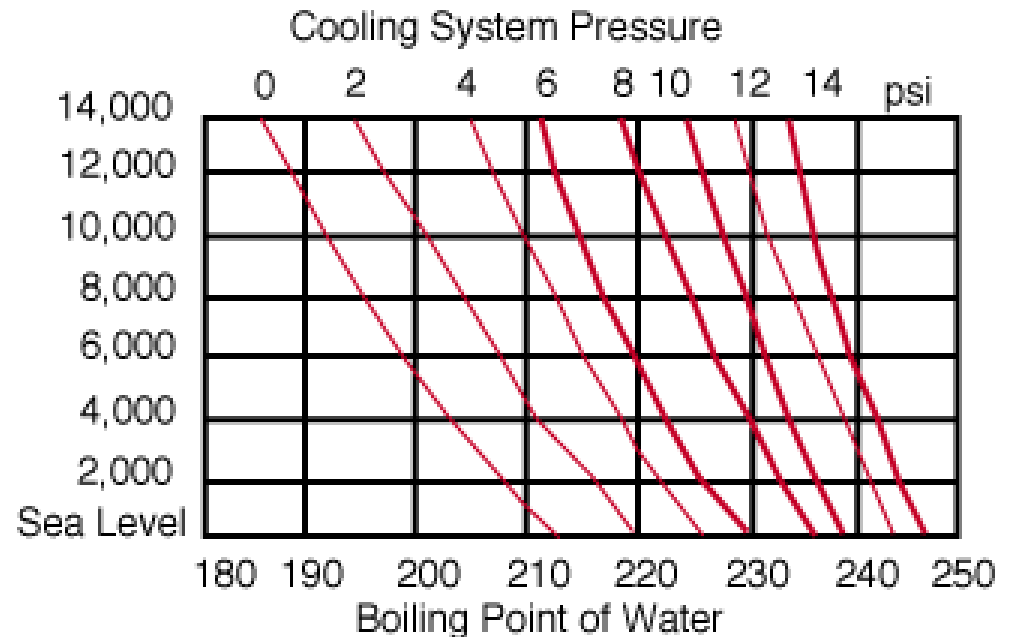

# PRESSURE CAP

- The pressure cap also improves the operation of the water pump.
- By keeping the radiator pressurized, the water pump has a constant supply of coolant to draw from.
- If pressure became too low, the coolant would boil and the water pump would draw only air.

# OVERFLOW TANK

- Contains reserve coolant.
- When cap releases coolant due to coolant expansion, coolant goes to overflow tank.
- When cooling system cools off and creates a vacuum, coolant is pulled from overflow tank.
- Some closed cooling systems do not have a cap on the radiator.
- The overflow tank is pressurized with the rest of the cooling system.
- The coolant level will be checked in the overflow tank.

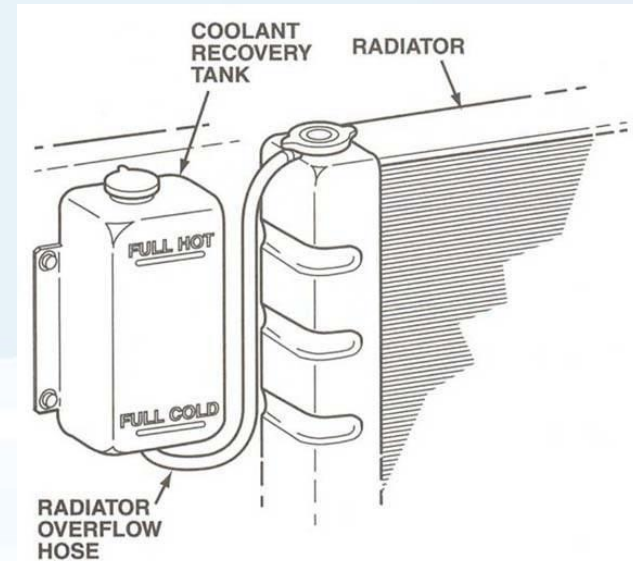

# BLOCK HEATERS

- Block heaters are small, electrical-resistance heater units that can be mounted in the block.
- These heaters are plugged into ordinary 110-volt ac outlet and are used in very cold areas to warm an engine while it is shut off.
- Block heaters provide easier engine starting and faster warm-up, especially for diesels.



# COOLANT FLOW

- The water pump pumps coolant through the block.
- If the thermostat is closed, coolant flows through the block, heater core, and the thermostat bypass.
- The bypass leads back to the water pump.
- There will be no flow through the radiator when the thermostat is closed.

# COOLANT FLOW

- When the thermostat is open, coolant is then allowed to flow from the block to the upper part of the radiator.
- The coolant is then cooled in the radiator.
- The water pump draws the coolant out of the bottom of the radiator so that it can then be circulated throughout the block to cool the engine.
- Some manufacturers position the thermostat on the inlet side of the water pump.
- As the cooled coolant hits the thermostat, the thermostat closes until the coolant temperature again causes it to open.
- This reduces thermal cycling (expanding and contracting of the metal).
- Thermal cycling can damage aluminum engine components

# COOLANT BYPASS

When the thermostat is closed, coolant is directed back into the block through the bypass passage.

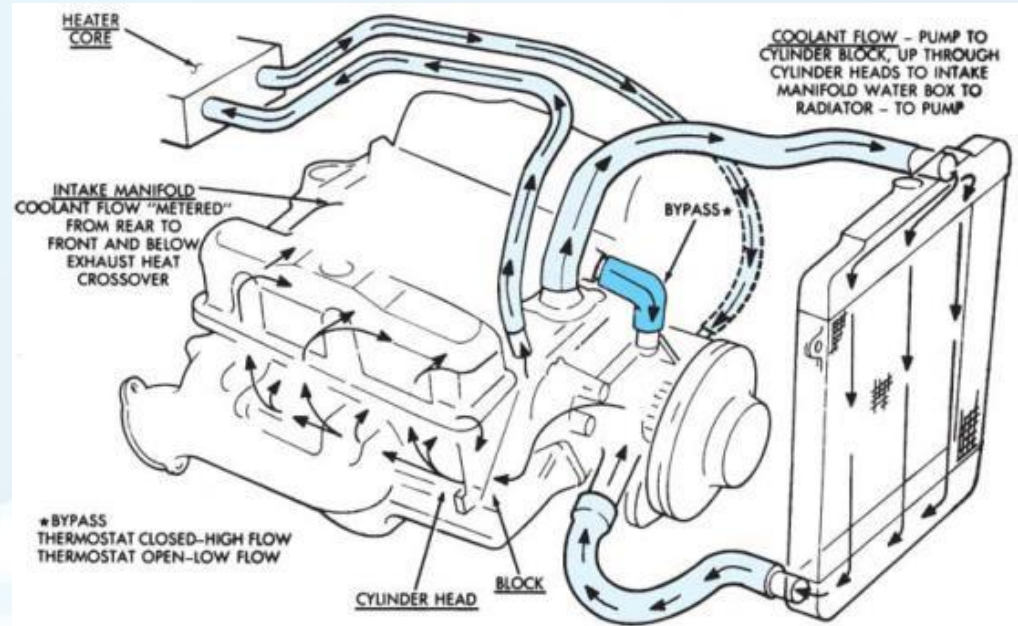

# COOLANT BYPASS

Some thermostats are designed to block off the bypass passage when they are open.

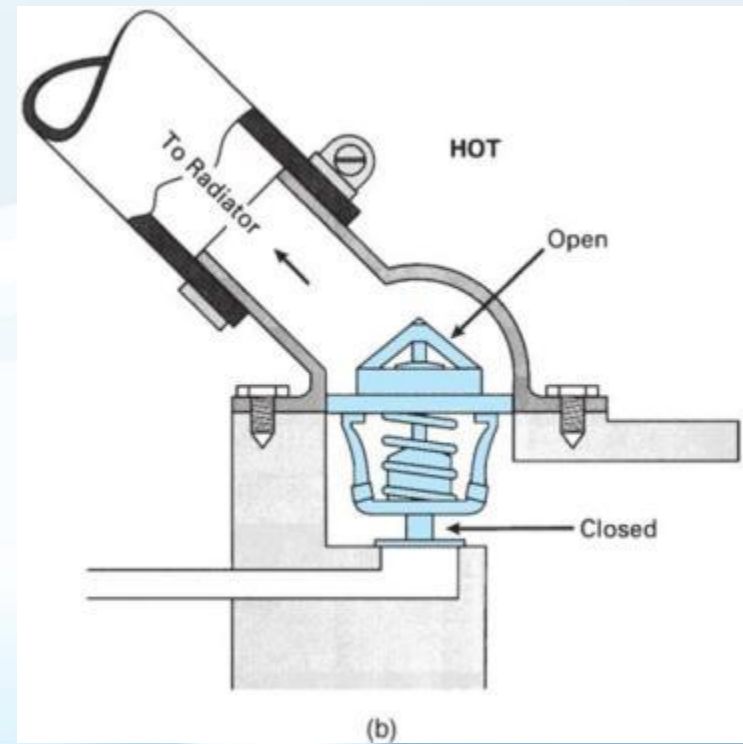
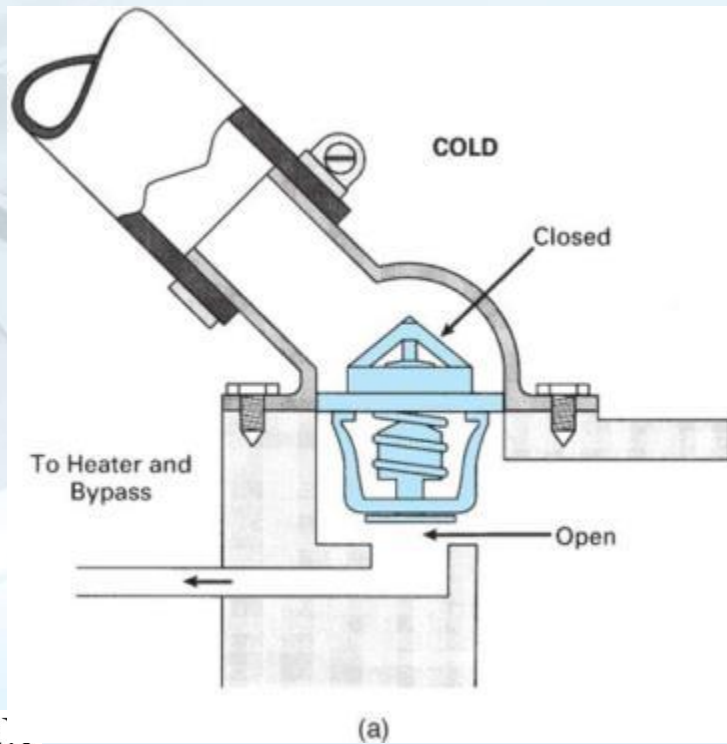

# THANK YOU

QUALITY

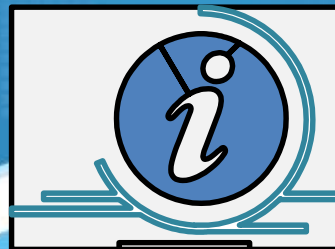

[Info-in@Omnex.com](mailto:Info-in@Omnex.com)

## Are there any Questions?

